



# Certificate

## OF PARTICIPATION

This Certificate is Proudly Presented to

**Dr. Rekha B Venkatapur**

in oral and technical presentation,  
recognition and appreciation of research contributions to

**8<sup>th</sup> INTERNATIONAL MARDIN ARTUKLU SCIENTIFIC RESEARCHES CONFERENCE**  
**June 04-06, 2022 / Mardin, Turkey**

with the paper entitled

**OBJECT DETECTION ON PANORAMIC IMAGES USING YOLOv5**

**Prof. Dr. Salih ÖZTÜRK**  
CONFERENCE HEAD





International Conference on  
**Intelligent Systems & Computation**  
**"ICISC 2022"**

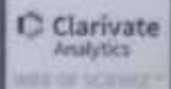

May 06-07 2022

In conjunction with

Organized by

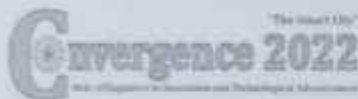

**Certificate of Presentation**



This is to certify that Dr./Mr./Ms. **Dr.Rekha B Venkatapur**  
of K.S.INSTITUTE OF TECHNOLOGY BANGALORE has presented a paper with  
Title "Quality Assessment System for Air Pollution Control in India through Calibration and Machine Learning Algorithm"

in the **International Conference on Intelligent Systems & Computation (ICISC-2022)**  
held on *06-07 May 2022* at *Poornima Institute of Engineering & Technology, Jaipur.*

  
**Dr. Rakhi Mutha**  
Convener  
ICISC2022

  
**Dr. Bhanu Pratap Singh**  
Program Co-Chair  
Convergence 2022

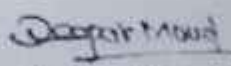
  
**Mr. Deepak Moud**  
Head of Department CSE  
PIET, Jaipur

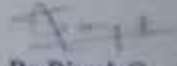
  
**Dr. Dinesh Goyal**  
Director & Principal, PIET  
Patron Convergence 2022



Conferences > 2021 Asian Conference on Inno... ?

# A Review on Security and Privacy Preserving Mechanisms of Electronic Health Records in Cloud

Publisher: **IEEE**

[Cite This](#)

[PDF](#)

Uma Hombal ; R. B. Dayananda [All Authors](#)

115

Full

Text Views



## Abstract

### Document Sections

I. Introduction

II. Literature Review

III. Security and

Privacy

## Abstract:

Over the past few years, storing the health records through electronic means are found to be of great use to the patients and treatment providers. These are considered as the most flexible and cost effective solutions for maintaining the health records of patients. Cloud based electronic health records enable collection of information about patients, maintaining their health records and organizing them to facilitate effective communication among patients and treatment providers. However, the major concern in this system is the security and privacy of the information. Lot of research has been done in recent years on this issue. This paper

### Acceptance Letter

**Author's** : Daneshwari A Noola, Dayanand R B  
Information Science and Engineering, BLDEA's V P Dr P G Halakatti College of  
Engineering and Technology, Vijayapura, India.  
Computer Science and Engineering, KSIT, Bengaluru, India.

**Manuscript Title** : Computer Aided Corn Leaf Disease Identification System

**Paper ID** : ICOSEC039

Dear Authors,

On behalf of the Conference committee, I would like to congratulate you on your to the ICOSEC 2021 IEEE Conference, which will be held from 7-9, October 2021 at Kongunadu College of Engineering and Technology, Tamil Nadu, India. You have been selected to deliver your oral presentation at the International conference on Smart Electronics and Communication.

As a result of the review and results, we are pleased inform that you can now submit the full-length paper for inclusion into the IEEE Xplore ICOSEC proceedings. We appreciate if you could send the final version of your research paper at your earliest convenience, in order to ensure the timely publication. When submitting your final paper, please highlight the changes made according to the review comments.

**All registered and presented papers will be submitted for inclusion into IEEE Xplore.**

Yours sincerely,



Conference Chair  
Dr. J. Yogapriya,  
Dean (R&D),  
Kongunadu College of Engineering and Technology,  
Trichy, India.

Proceedings by



[ICOSEC 2020 Publication @ IEEE](http://icsec.in/2021/)

# **Computer Aided Corn Leaf Disease Identification System**

<sup>1</sup>Daneshwari A Noola, Information Science and Engineering, BLDEA's V P Dr P G Halakatti College of Engineering and Technology, Vijayapura, India, ise.daneshwari@bldeacet.ac.in

<sup>2</sup>Dr Dayanand R B, Computer Science and Engineering, KSIT, Bengaluru, India, dayanandrb@ksit.edu.in

**Abstract:** Corn is one of the most beneficial and productive food crop in the agriculture field and massively produced across all over the country. However, occurrence of varied leaf diseases can impact heavily on their production rate. Those diseases can be common rust, cercospora- leaf-spot gray and northern leaf blight etc. Therefore, precise and timely detection of these diseases is very crucial for maintaining the demand and supply of corn crop. Therefore, an enhanced K- Nearest Neighbor (EKNN) based classification technique is adopted for the identification of corn leaf disease in initial stages to avoid heavy damage to the corn crop. The proposed EKNN model provide detailed information regarding leaf disease images and extract rich features like Fine and Coarse features. Then, classification process is performed on obtained features to get high classification accuracy. The efficiency of classification process is enhanced using combination of Local Intensity Interactions Function (GIIF) and Global Intensity Interactions Function (GIIF) and histogram gradient of features is obtained using this methods. The proposed EKNN model precisely predict that leaf disease images belongs to which class based on the obtained feature weights. The proposed EKNN model provide high performance results than any other classification models considering performance metrics like classification accuracy, precision, recall and F1-measure.

**Keywords:** Enhanced KNN model, Corn Classification, Feature Extraction, Leaf diseases, Plant-Village Dataset

## **1 Introduction:**

Plants are the main reason to keep the environment healthy. Moreover, plants can be utilized for several purpose and in various fields like agriculture, cosmetic industry, medicine, foodstuff preparation, environmental growth and ecological protection as well. Furthermore, plants constantly utilized in daily life activities and plays pivotal role in human growth as well as all aspects of human life [1]. Moreover, plants majorly contributes towards economic growth of the country. There are several plants which are utilized in variety of food making stuffs and exported outside the country as well. One of those major contributor towards economic growth and production for variety of food products is corn crop which is majorly produced in different part of the country every year. However, maintenance and keeping the corn crop disease free, is one of the major challenge in large production of corn crop. Moreover, corn crop can have variety of diseases like Black Rot, Northern Leaf Blight and Rust, if precautions and maintenance measures are properly not followed. Presence of disease in plants can have a major impact on plant growth. These diseases can impact major parts of the plant like flower, stem, leaf and fruit. In addition, these diseases can impact heavily on corn crop yield and production and can pose a severe threat to Global food security. Thus, identification of those plant diseases is very essential to keep the plant healthy. However, timely identification of these diseases can reduce the impact on crop yield to a significant extent.

Moreover, manual intervention is utilized in many cases for plant detection and classification. The pathological experts constantly analyse behaviour of plant over a long period of time from naked eye

# MORSE CODE SECURITY

Dr. Rekha B Venkatapur<sup>1</sup>, Pujari Vishnupriya<sup>2</sup>, Dandu Niharika<sup>3</sup>, N. Sai Jahanavi<sup>4</sup>, Bhavani KG<sup>5</sup>

<sup>1-3</sup> Department of Computer Science and Engineering,

Visvesvaraya Technological University (VTU)

[rekhabvenkatapur@ksit.edu.in](mailto:rekhabvenkatapur@ksit.edu.in)

K. S INSTITUTE OF TECHNOLOGY

Bangalore, Karnataka - 560109

**Abstract**— Morse code is one of the before time telecommunication which is infrequently used now a days due to the vivid ways of communications. Seeing that utmost of the people in the world face barriers in the field of authentication and security. In this design, real time eye tracing allows people to authenticate themselves using Morse code. Here the Gaze based authentication refers to detecting the eye position using successive frames of images and tracking eye center overtime. The password is authenticated using Morse code where the alphabets, numbers and special symbols are represented by dots and dashes independently. This model provides a real time operation for Gaze-based PIN entry, eye detection and tracking for the identification of the PIN using smart camera.

**Keywords**— Authentication System, Eye Blink, Face Recognition, Machine learning, Morse code, Personal Identification Numbers.

## I. INTRODUCTION

The change or development in our life is due to technology advancement we have inculcated in our day-to-day life. Within the boundaries of a sophisticated society, vast gains of technology related revolution have exceeded the other side formation. The huge amount of both unstructured and structured data recognizes the patterns from which the organization gets benefited by expenditure control, managing risk and analyzing various market opportunities which increases the competitive advancement, Holding usability and secrecy to analyze result is the principle of psychological assumptions. The security will be adding a possible matter for the action that the user performs. This project accounts with those factors to gain the output which is easy to reach user interacting systems. As in the present scenario there are no much utilities for the physically challenged, that incorporates with the traditional group. Scaling back the load on the physically challenged people is attained which makes them more unified within the society. The scope of the project is to provide a securable process to all the kinds of people be it the young or the old which incorporates the Differently Abled.

## II. EXISTING SYSTEM

Headway in the innovation of verification and approval has been upheld in the 21st century. Individual ID numbers (PINs)

are generally utilized for client verification and security since the last part of the '90s. The current framework incorporates entering the secret key or the PIN through a QWERTY console or a numeric console which leads actual path when entered. The current look-based framework is carried out with the numeric PIN by utilizing the following of eye development recognition.

### Disadvantages of Existing System

- The existing system projects lack of security considering that the shoulder surfing method for hacking can be easily implemented.
- Entry of the PIN numbers can be easily traced as it leaves physical footprints behind.
- Most of the system have only one layer of authentication.
- The existing gaze-based system is inconvenient as it is done by eye tracking and it maps the numbers directly on the screen.

## III. PROPOSED SYSTEM

The model consists of a user interface and a back-end database. GUI is created such that the user can interact with the system. Tkinter or OpenCV is used to create the GUI. In the front-end firstly, the user needs to register by giving in an ID and a name. Once this is completed, the process of Face Recognition takes place and this information is stored in the database associating it to your respective profile. Later, the user needs to register by providing a user id of choice, a password (PIN), and a keyword. After registration, the user can log in by using the credentials i.e. user id and password. With the help of a web camera, the PIN is taken as input in the form of Morse code. The project is achieved using Morse code encoded through eye blinks. Here, we discuss Morse code detection from eye blinks and decoding using OpenCV. In the backend, the entered PIN is checked with the stored PIN which was entered into the database by the user while registering. If the entered PIN is incorrect, the system exits the screen. If the entered PIN is correct, it displays successful authentication. If the user has forgotten his password, then he can use the keyword to authenticate and update the existing password with a new one.

# A Survey on Anti-Keylogger

Dr. Rekha B Venkatapur<sup>1</sup>, Shashank Mishra<sup>2</sup>, Maddula Jitendra<sup>3</sup>, Arvind Pathak<sup>4</sup>, Saurav Kumar<sup>5</sup>

<sup>1</sup>Professor & Head, Computer Science & Engineering  
K.S.Institute Of Technology(VTU), Bangaluru, India  
-rekharvenkatapur@ksit.edu.in

<sup>2,3,4,5</sup>Final Year Student, Computer Science & Engineering  
K.S.Institute Of Technology(VTU), Bangaluru, India  
<sup>2</sup>shashankmishra.0598@gmail.com  
<sup>3</sup>jitendramaddula@gmail.com  
<sup>4</sup>arvindpathak96445@gmail.com  
<sup>5</sup>sauravkumar8k@gmail.com

**Abstract**— An anti-keylogger is a program that specializes in detecting and identifying keystroke logging software which is also capable of fixing or at least immobilizing hidden keystroke logging software. Of late, Cyber crimes have been witnessed as a major threat to the prudence of data owned and maintained by firms. Leveraging keylogger has made it easier to collect information. Depending on the type of keylogger being used, the keystrokes can either be discovered using a software keylogger or by a hardware keylogger. Keylogger software can be detected using some anti-keylogger programs. In some cases, hardware keylogger may not be detectable by software, since they are connected externally to the CPU and don't participate in the CPU's activities. These key loggers may pose a serious threat if not detected in time.

**Keywords**-Keylogger, Cybercrimes, Anti-keylogger, Malware, Security

## I. INTRODUCTION

The Malware is a software that design to leak private or sensitive information or gaining unauthorized access to system across the globe. Detecting and preventing malware attacks is really important in cyber world [1]. As nobody wants their private and sensitive information to be leaked someone else without their permission. This may cause financial loss, highly classified data can be leaked etc. There are different types of malware that can retrieve user data to hacker or attacker. Such malware are virus, Trojan, worms, spyware, rootkit etc. Defence against keylogger and such malware that can retrieve the sensitive information to others can be done with the help of Anti-keylogger. Anti-keylogger are against of privacy breaching and also anti-keylogger provides to user a free and safe environment from the keylogger and different types of malware attacks that could be done through hacker or attacker. Anti-keylogger is a type of software that is developed in such a manner that can detect any keylogger present on the system that can retrieve our important or sensitive credential to any third parties or to hacker. Therefore, an Anti-keylogger is used against keylogging software or any malware software that can process in background. Anti-keylogger detect keylogger program's or software in our system and then either

it can eliminate them or delete data collected by them and it can also immobilized our hidden keystroke logs or will warn us about existence of any keylogging software present on our system. This is used to protect the keylogging activities from taking place on the system and Personal details or sensitive information can be saved.

### 1. Signature based detection

In this process of detection, anti-keylogger detects that particular keylogger that is listed as a keylogger on the sites. It will scan all the files present on the systems and if it will get any keylogger file or any keylogger present on the system then it will show that particular file as a threat file or malicious file. Even it will also provide all the details that why it marked as threat file out of other files. Signature based detection main disadvantage is it will detect those keylogger who all are listed so it can not detect any other keylogger out of given list to it[6]. Drawback is hacker can rename keylogger and can retrieve all the information without the user knowledge.

### 2. Behavioral detection

It focused on the general problem of detecting malicious files or software behaviour. This process of detection is also known as heuristic analysis that helps to detect any keylogger present on the system with the help of file or any program behaviour. if any software or program is trying to harm system or even any program perform malicious function. it will detect them and terminate that particular program by showing warning to user that particular file or program is harmful for your system. Sometimes it is used to block non-harmful software because it monitors the some different activities of that particular software.

# Vehicle type recognition from surveillance data based on deep active learning

Rekha B Venkatapur<sup>1</sup>, Vindhya M<sup>2</sup>

<sup>1</sup>Professor & Head, Computer Science & Engineering  
K.S.Institute Of Technology(VTU), Bengaluru, India

<sup>1</sup>rekhabvenkatapur@ksit.edu.in

<sup>2</sup>Final Year MTech Student, Computer Science &  
Engineering K.S.Institute Of Technology(VTU),  
Bengaluru, India

<sup>2</sup>vmanjegowda67@gmail.com

**Abstract**— Vehicle type recognition (VTR) from surveillance data has recently received increasing attention in both intelligent transportation and computer vision field. The deep learning techniques, e.g., convolutional neural networks (CNNs), have provided great progress in tasks with the large-scale labelled data. However, in real-world applications, manually labelling from large-scale surveillance data is time-consuming and tedious, which strongly obstructs the application of a CNN-based VTR. The existing works on VTR studied samples selection for manual annotation. Here, a VTR framework based on deep active learning that releases the burden of large-scale labeling is presented. The framework selects the most worthy samples to be manually selected, and then retrains the network with the annotated samples incrementally. Besides, the framework simultaneously takes advantage of both auto-labeled and manually-labeled data using the strategy of bi-direction entropy threshold. The proposed framework is validated on the public dataset Comprehensive Cars, and experimental results demonstrated that, with the incremental query strategy, the proposed framework could reduce annotation cost dramatically compared with random selection.

## I. INTRODUCTION

A Video-based intelligent transportation system plays an important role in the smart city concept. In this concept, there are tons of cameras located all over the cities, and a large amount of surveillance videos can be obtained with a low cost. A vehicle type recognition (VTR) is one of the key issues in video-based intelligent transportation systems, e.g., traffic monitoring, toll stations operation. The VTR also reflects the economic and cultural level in a certain region. Thanks to previous works on computational science such, VTR work could be accomplished in more efficient way. Vehicle type is associated with the license plate or vehicle logo.

Department of CSE, K S Institute of Technology, Bengaluru

Therefore, it would be ideal to recognize the vehicle type directly from the surveillance data.

Most of the vehicle type recognition methods can be categorized into two categories: coarse-grained classification, which classifies vehicles into bus, mini-cars or truck, and fine-grained classification, which achieves the detail information on vehicle categories, such as vehicle maker and vehicle model, or both of them. The method we propose here belong to the second category. A VTR framework based on deep active learning is proposed in this work. A deep neural network is trained efficiently by actively, incrementally and automatically selected unlabelled samples from the oracle for manual annotation. The training procedure is repeated several times; therefore, the neural network is retrained with the incrementally updated training data.

### 1.1 Problem Focused

Deep learning techniques have enabled diverse practical applications of vehicle attribute recognition. In this paper, we will discuss the following three problem settings:

- Vehicle type recognition attempts to characterize vehicles to coarse-grained categories by their size or intended usage, e.g., sedan, bus and truck. A common use case is statistical: What is the distribution of vehicle categories at a specific checkpoint?
- Vehicle make recognition categorizes vehicles by their manufacturer, e.g., Ford, Toyota and Chevrolet. An example use case is searching for stolen vehicles or license plates: Did the make of this vehicle change since last month?

Vehicle model recognition learns to predict the vehicle model, e.g., Ford Figo, Toyota Corolla and Chevrolet Volt. This task is significantly more detailed than the aforementioned vehicle make recognition, and it can be used as a method to study consumer behaviour regarding a specific vehicle model.



## Critical Survey for Scheduling and Resource Allocation Methods in Hadoop-MapReduce on Clouds

Vaishali Sontakke<sup>1</sup>, Dr. Dayananda R B<sup>2</sup>

<sup>1</sup>Department of information science and engineering, East point college of engineering and Technology, Bangalore, Karnataka, India

<sup>2</sup>Department of Computer science and engineering, KSIT, Bangalore, Karnataka, India

### ABSTRACT

Cloud computing is defined as the computing platform which hosts the various services and application for the users and businesses. It provides the access to the users with less cost and easily accessibility from any part of the world and works on the theory of Pay as you go service. In cloud environment computing resources provided as they demanded. It forms upon developments of virtualization. Cost of computing resources, highlighting towards resource scalability and provided on-demand services. It permits business consequences to upgrade and degrade their resources based on requirements. Meanwhile an open source Hadoop performance MapReduce has become a widespread model for data-intensive application for short job and low response time. IN this paper, we study the works on scheduling and resource allocation for matching the processing load .We provide the comparison of the same, comparison includes the various methodology along with their shortcomings.

**Keywords :** Hadoop, Mapreduce, Survey, Scheduling, Resource Allocation.

### I. INTRODUCTION

Cloud environment is a recent technology to offer services to clients at a little time that is fast serving time . As growing number of current applications develop data-intensive in nature. In the past era, the World Wide Web has been embraced as an perfect platform for emerging data-intensive applications, meanwhile the communication model of the Web is more open and powerful[1]. Search engines, online auctions, webmail, and online retail sales are illustrative data-intensive Web applications where data mining and web indexing necessity to entree expanding data sets which ranges from few gigabytes

to several terabytes or now a days petabytes. For example, in Google the MapReduce model processing parallel nearly twenty petabytes of data per day. Cluster computing environments for parallel data processing with high-performance MapReduce is an attractive model. The scalability of MapReduce is verified as high, since a job in the MapReduce model is segregated into abundant block, the appearance of section headings, document margins, column width, column spacing and other features.

Small tasks successively on several machines in a large-scale cluster. Hadoop is popular open-source implementation of the Google's MapReduce model is mainly developed by Yahoo [3]. Yahoo servers using

# Survey on Developing a Secured E-commerce Application for purchasing Electric Vehicles

Mr Harshavardhan J R <sup>1</sup>, Shashank G <sup>2</sup>, Harshith C Prasad <sup>3</sup>, Gunal Binani <sup>4</sup>, Bhagawat Gowtam <sup>5</sup>

<sup>1</sup>Associate Professor, <sup>2,3,4,5</sup> Undergraduates ,  
Department of Computer Science and Engineering,  
K S Institute of Technology,  
Bangalore, Karnataka.

**Abstract** — EV- Mart is an e-commerce application that will serve as a central purchasing point for upcoming electric scooters, next-generation electric cars, and accessories. Users will be able to purchase these vehicles from the comfort of their own homes, with a wide range of options available on a single screen. EV-Mart is a business-to-consumer (B2C) e-commerce platform that will serve as a retailer or a conduit between various electric car manufacturers and end users or customers. Consumers will have various alternatives to choose from, regardless of the company's unique products. This year's EV sales surge is expected to continue, signaling that the migration to electric cars is picking up speed. The most significant transition is taking place in the two-wheeler market, where electric two-wheelers have been driving volume increase in recent days. In November 2021, registered electric two-wheeler sales increased by more than five times, to 22,450 units, compared to roughly 4,000 units in November 2020. Electric two-wheelers increased by 17% month over month, according to data from the CEEW (Council on Energy, Environment, and Water). These figures support the necessity for e-commerce in this industry. We will build EV – Mart as a platform or a hub for electric vehicles, assisting customers in making decisions about which EV to buy depending on their needs

**Keywords** — E-commerce, electric vehicles, recommendation systems, security, MVC – architecture, Business

## I. INTRODUCTION

E-commerce aids nations in improving trade efficiency and facilitating emerging countries' entry into the global economy. It enables firms and entrepreneurs to compete on a more level playing field. Many of the restrictions of conventional business were eliminated with this kind of dealing. The existence of virtual marketplaces, routes, and shops that do not take up physical space, enabling access and circulation in these markets for a brief period of time and from anywhere in the globe without leaving home. Select and order things that are advertised on virtual networks and put in virtual shop windows in unidentified regions of the globe, with payment made using electronic services. "The Indian E commerce sector has seen a

big upswing as a result of COVID-19, and there is much space for future expansion," said Phil Pomford, managing director of FIS' Asia Pacific Worldpay. According to the analysis, online shopping will fuel India's e-commerce business, which is expected to increase at a rate of 21% annually over the next four years and the most common payment methods online in 2020 were digital wallets (40 percent), credit cards (15 percent), and debit cards (15 percent).

## There are 6 basic types of e-commerce:

1. Business-to-Business (B2B)
2. Business-to-Consumer (B2C)
3. Consumer-to-Consumer (C2C)
4. Consumer-to-Business (C2B).
5. Business-to-Administration (B2A)
6. Consumer-to-Administration (C2A)

"E-commerce is no longer restricted to conventional websites, and physical retail has become more integrated with the digital world. Consumers want the same hassle-free and quick shopping experience whether they purchase through an app, through their social feeds, or in person. If merchants prioritize the consumer experience throughout the checkout process, they will be well positioned to succeed. "Those that position themselves with digital payment capabilities will be well-positioned to exploit the next wave of development in India's retail and E-commerce markets," the research said.

## II. LITERATURE SURVEY

[1] This study presented that the creation of web applications has been eased because to MVC pattern design and integrated technologies such as JSP, Servlet, and EJB on the J2EE platform. Because it splits the logic of the program into three levels, the MVC design allows for simultaneous development. Each developer may work on these three layers of the same web application at the same time. A user may make a request to our program and receive a response via the controller layer. It mostly

# Online Whiteboard

Mr. Harshavardhan J. R<sup>1</sup>, Md. Sujan<sup>2</sup>, Manvith P<sup>3</sup>, Nikhil Vasan<sup>4</sup>

<sup>1</sup> Associate Professor, <sup>2,3,4</sup> Students  
Dept of Computer Science and Engineering,  
K S Institute of Technology,  
Bengaluru, Karnataka.

**Abstract**— Human connection is more important than ever as the world battles COVID-19. The internet plays an important role in connecting people throughout the world. Many businesses have taken certain measures to connect and collaborate in these unwanted times leading to an increase in demand for online collaboration tools. A tool widely used in such places to collaborate and connect is a whiteboard. In this paper, we develop a tool to increase collaboration without restricting people to any location, any particular OS, or any particular device needed. Our application allows users to interact and collaborate through visual annotation, making diagrams, uploading images and models/sketches interactively that can be shared with all participants connected over the network in real-time. The tool does not require any plug-in to be downloaded, it is easy to use and has no limit on the number of clients. We have implemented this system by using socket connections and canvas API.

**Keywords**— Online Whiteboard, NodeJS, Sockets, Transfer Control Protocol.

## I. INTRODUCTION

“Online-whiteboard” is a free and easy to use web application which allows the users to host an online whiteboard on which they can collaborate and use it to annotate their ideas, explanations, drawings, presentations without the need of sharing the screen.

Meetings and classrooms demand the presence of the person in the room if he/she wants to participate. A tool widely used in such places is a whiteboard. A virtual whiteboard is a shared whiteboard application where multiple clients can connect and write, share, and interact with each other in real-time without needing to be in the same physical location.

## II. PROBLEM IDENTIFICATION

The main problem here is the inability to express ideas, facts and explanations visually during online meetings. There is also difficulty in collaborating with other parties of the meetings for sharing and expressing their ideas. If the program uses up a lot of memory due to high graphical interphase and other methods, this in turn will cause the system to hang. It needs to have good security measures so that nobody will be able to misuse the features which are available to them.

## III. PROBLEM STATEMENT

Online meetings and video conferences have skyrocketed due to Covid-19, many systems cannot handle the high graphic interface of a few websites, our whiteboard consumes very little memory and bandwidth. Our whiteboard has a simple UI/UX which makes it very easy for the user to navigate and use the whiteboard. Another problem is that majority of the whiteboards have features but they need to be purchased to be usable, which makes it difficult for small organizations to afford the board.

## IV. LITERATURE SURVEY

[1] Prakhar Gupta, Vasudha Bahl analysed multiple white boards to understand how the ability to attach files works. They also analysed a few collaboration features such as commenting, messaging, audio and video calling features.

[2] Didik Dwi Prasetya, Mohammad Ashar worked on the design of interactive white board to support E-learning. Electronic learning offers an effective solution that enables the creation of virtual classes. Unfortunately, the limitations of learning media features cause visual communication to be difficult, so that the explanation of the material is less easy to understand, especially in relation to illustrations, sketches, diagram, and modelling.

[3] Hyosook Jung, Woochun Jun, Le Gruenwald conducted a study on design and Implementation of Web based, Project based learning support system. It was noted that Teachers and students are now using the Web to access vast amounts of information and resources in the cyberspace. Also, learning via the Web enables both synchronous and asynchronous communication. Despite of many benefits of the Web, it may weaken student's motivation due to lack of face -to-face communication.

[4] Akshay Sharma, Shailu Bashambu advocated on using Color Blind-friendly mode, they also made a crucial point that Human connection is more important than ever as the world battles COVID-19. The internet plays an important role in connecting people throughout the world. Many businesses have taken certain measures to connect and collaborate in these unwanted times. This has led to an increase in demand for online collaboration tools for connecting people throughout the world. A tool widely used in such places to collaborate and connect is a whiteboard.

# Bird Species Identification

Deepa S R<sup>[1]</sup>, R Pratiksha<sup>[2]</sup>, Sujay G S<sup>[2]</sup>, Sourabh Santosh Kamble<sup>[2]</sup>, Sudhanshu Joshi<sup>[2]</sup>,

<sup>[1]</sup> Associate Professor, <sup>[2]</sup> Student,

<sup>[1][2]</sup> Dept of Computer Science and Engineering,

<sup>[1][2]</sup> K S Institute of Technology, Raghuvanahalli, Bengaluru, Karnataka.

**Abstract**— Birds are considered the most cherished aspect of God's creation. They support the biodiversity of the earth in various ways. And are extremely sensitive to climate and habitat change, thus indicating environmental hazards. Ornithologists who frequently work on reporting bird activity need some assistance to identify the species. Many bird books have been published to help birdwatchers and ornithologists identify the correct species. However, bird identification is an unrealistic task to be done manually. Wiings is a client-server application used to identify and classify bird species. This project is manually trained using data annotation techniques and these data are expanded in the data expansion step. The project utilizes the YOLO algorithm and deep learning concepts to predict outcomes. Higher than the threshold it draws a bounding box with a confidence value and returns the bird class.

**Keywords**— Bird species detection, YOLO, Ornithologists, Image identification, bounding boxes, annotations, confidence level, augmentation

## I. INTRODUCTION

Nowadays life of individuals is stressful and requires some sort of recreational activities. Birdwatching is one such hobby which can provide relaxation and promote a stress-free life. It offers various health and fitness benefits and by means of enjoying nature happiness can be derived.

A number of people visit bird sanctuaries to praise the beauty of various bird species while barely spotting the variants among them. Understanding such differences can expand our knowledge of birds in addition to their ecosystems and biodiversity. However, due to constraints like distance, equipment and region identifying birds with the bare eye is tedious. In the present world, most of the identification systems depend upon images to accurately recognise the species. The classifiers can accurately identify the bird species after exposing to enough training data. Accurate identification of birds is the idea for all factors of pastime reporting and research.

To classify the beauty of birds, the Wiings application utilises Yolo algorithm to extract data from the bird images captured formerly or in real time. Eventually, the client-server architecture is used to retrieve the information and predict the bird species using the trained model which is on the server. The application also provides the location of large flock of certain bird species and is dedicated to the Kingdom of birds.

## II. LITERATURE SURVEY

Yo-Ping Huang and Haobijam Basanta created a model for bird species recognition using a dataset of 27 endemic Taiwanese bird species. The Internet of Birds, a smartphone application, was used to do this (IoB). The CNN with skip connection was used to implement this model. CNNs are analysing bird photos to find their distinguishing characteristics. To improve the colour and shape of object details, bounded zones of interest were constructed. Additionally, skip connections were employed to integrate the outputs of previous and current layers in a linear fashion. Skip connections were used to improve feature extraction. A function called softmax was used to obtain the probability distribution. The output layer returns (a) image chunks with birds, (b) kind of bird species, and (c) a portion of the input image that does not contain a bird. To detect output of images with or without birds, a multiscale sliding window method was used [1].

Satyam Raj, Saiaditya Garyal, and Sanu Kumar created a model utilising the Convolution Neural Network, a Deep Learning technique. The initial phase in this project is convolution, which is followed by a Rectified Linear Unit, which helps to reduce the size of the image we offer as an input. The main purpose of this application is to use a photograph to identify the features of each individual bird. It entails the following procedures:

1. Gathering all of the bird species' datasets, which totaled roughly 60 bird species and 8220 photos.
2. The CNN architecture, which is a more separable version of the VGG network that is being created.

# Hand Gesture Recognition for Differently Abled People

Deepa S R<sup>1</sup>

Goutham M<sup>2</sup>, Dhananjaya S<sup>2</sup>, Kiran V Dambal<sup>2</sup>, Ganesh A<sup>2</sup>

<sup>1</sup>Associate Professor, Dept of Computer Science and Engineering, K S Institute of Technology, Raghuvanahalli, Bengaluru, Karnataka

<sup>2</sup>Student of K S Institute of Technology, Raghuvanahalli, Bengaluru, Karnataka

\*\*\*

**ABSTRACT:** Hand gestures are the most basic method of human communication. Today, in the age of modern invention, gesture recognition has a variety of applications, ranging from physically handicapped humans to robotic control. Human hand gestures are a natural and effective way to communicate with a computer system without saying anything. Deaf and mute people communicate via sign language, which is difficult to understand for those who aren't familiar with it. Creating a gadget that can translate motions into text and speech is necessary. To address this issue, the system developed here will employ a Tensorflow-based Deep Learning Model to comprehend gestures, take images, and finally output the result of the user's gesture.

**Keywords:** Hand Gesture, Tensorflow, Deep Learning, Image Processing, Computer vision, Text, Audio.

## I. INTRODUCTION

Due to birth abnormalities and other issues, the population of deaf-dumb victims has increased in recent years. Because a deaf and mute person cannot communicate with a normal person, they must rely on a quiet communication device. They utilize hand gestures to communicate and sign language is quite popular among them. Gestures can be a representation of physical conduct or an expression of emotion. It incorporates both hand and body movements. It is primarily divided into two categories: static gestures and active gestures. For the prior, a symbol is denoted by the body position or hand gesture. The hand gesture denotes equivalent signals in the latter case. The popularity of a gesture or movement of the body or body parts is used to determine the user's purpose. Many academics have worked for decades to improve hand motion detection technology. Hand gesture detection is useful in a variety of applications, including language recognition, video games, impaired language interpreters, and golem management. Because of the new generation of gesture interface technology, the importance of gesture recognition has grown at a rapid rate. Sign language is

very useful for people who are differently-abled (deaf-mute) and cannot communicate with others through spoken languages. Though people will notice, using hand signs to move becomes cumbersome to express one's feelings quickly if standard hand language is not followed. A traditional language has a clearly defined collection of signs and their meanings, making it easy to understand. For communication, the language employs a variety of gestures, the most common of which is the hand. The spoken and sign languages are not the same. Because hands provide more clearer signals and can be formed ad-lib, hand gestures are used more frequently for interacting with humans and technology than other body movements such as head and eyes. Deaf and mute people are becoming more outgoing these days, and unlike in the past, they no longer rely on others for communication. As a result, it is critical that the public around them understand what they require in order to educate them about exploitative language. The idea is to design the hand gesture recognition system for such people so that even if they don't understand the meanings of the gestures, they may use the program to recognize the message being conveyed. As a result, there are no communication barriers for deaf and mute people.

The proposed system is expected to give an accuracy of 93%.

## II. LITERATURE SURVEY

[1] Parshwa P. Patil, Maithili J. Phatak, Suharsh S. Kale Adaptive Boosting, Motion Detection, Region of Interest, and Thresholding techniques were used to construct a model for Deaf and Dumb Hand Gesture Recognition. With a minimal feature vector size of 8 features, this model produced decent classification results of 73.68 percent.

[2] Kundan Kumar Dubey, Ajitanshu Jha, Akshay Tiwari, K. Narmatha built Hand Gesture Movement Recognition System Using Convolution Neural Network Algorithm was created using OpenCV, Computer Vision, and Deep Learning. One of the strategies utilized to increase the accuracy of the model was Inception v3. Without the usage of any picture region selection framework, the suggested system is capable of

# BLOCKCHAIN BASED FOOD TRACING SYSTEM

Vaneeta M<sup>[1]</sup>, Varidhi Madhuranath<sup>[2]</sup>, Sindu A.S<sup>[3]</sup>, Vyjayanthi K S<sup>[4]</sup>, Supreetha G<sup>[5]</sup>

<sup>1</sup>Associate Professor, <sup>2,3,4,5</sup>Undergraduates

<sup>1</sup>Department of Computer Science and Engineering,

<sup>1</sup>K S Institute of Technology, Bangalore, India

[vaneetam@ksit.edu.in](mailto:vaneetam@ksit.edu.in) [varidhim08@gmail.com](mailto:varidhim08@gmail.com) [0908.sindu@gmail.com](mailto:0908.sindu@gmail.com)

[vyjayanthiks07@gmail.com](mailto:vyjayanthiks07@gmail.com) [subbireddy510@gmail.com](mailto:subbireddy510@gmail.com)

**Abstract**—Traceability is now transformed into a fundamental viewpoint in supply chain administration, especially in safety-sensitive businesses like food. Consolidating blockchain innovation into food traceability can move forward supply chain administration, brand notoriety, buyer certainty, quicken item improvement, and diminish obligation dangers. This review employs expressive and substance examination to inspect distributions related to blockchain-based supply chains and traditional supply chains. To completely inspect blockchain-based supply chains, four well-designed questions are being proposed and tended to, specifically, the esteem of incorporating blockchain into supply chains, the fascination of researchers to specific supply chain topics, the improvement of inquiring about strategies, and outline sorts in receiving supply chain applications of blockchain, and the sorts of businesses included in supply chains that use blockchain. The review considers points to examine the present-day standing, potential uses, and succeeding proceedings of this technology in supply chain administration. The objective of the study is to give an overview of blockchain-based supply chain investigation, along with an overview of the current state of literature, and highlight the advantages and troubles in incorporating this ideology. Chosen compilations were reviewed to create an abstract of supply chains utilizing smart contracts and blockchain. This paper provides valuable data to assist researchers and professionals to probe the relevant points to quicken the improvement of blockchain-based supply chains.

**Keywords**—Blockchain, Food Supply Chain, Smart Contracts, Traceability, Ethereum

## I. INTRODUCTION

In the last few years, the expansion of investigation, ventures, and dialogs concerning shared ledger technology has progressively pulled

in the thought of analysts and professionals. The rationale is the features that it provides, such as upsetting the existing structure of centralized frameworks. It alludes to an uninterrupted record of time-stamped records successively connected using cryptography. This makes it a permanent, secure, and trustful show where exchanges among parties are concerned. A few topics have been in the last few years, the expansion of investigation, ventures, and dialogs concerning shared ledger technology has progressively pulled in the thought of analysts and professionals. The rationale is the features that it provides, such as upsetting the existing structure of centralized frameworks. It alludes to an uninterrupted record of time-stamped records successively connected using cryptography. This makes it a permanent, secure, and trustful show where exchanges among parties are concerned. A few topics have been explored utilizing this concept and supply chain administration is one of the developing applications. In this paper, a study on conventional and blockchain-based systems is done that describes some of the supply chain obstacles. The goals and inspiration in the reviewed publications are distinguished highlighting the results of the system used. To solve many issues regarding the supply chain, information is needed to be unchanging as well as open. Blockchain could be an encouraging innovation having the capability to fulfill numerous supply chain challenges. Supply Chains include different members and partners and various forms in different stages. Any process in a supply chain consists of a sequence of individual steps, which shall be described by a manageable number of general activities. They have ended up more worldwide, complex, and interconnected over stages. Fig 1. underneath portrays the occasions and substances that take a portion in a commonplace nourishment supply chain.

# Immutable Industrial Air Quality Management System

Vaneeta M<sup>1</sup>, Ashwini J<sup>2</sup>, Kruthika S Vasisht<sup>3</sup>, Nikitha M<sup>4</sup>, Srividya H.R.<sup>5</sup>

<sup>1,2,3,4,5</sup>Computer science and engineering, K S Institute of Technology  
14, Kanakapura Rd, Raghuvanahalli, Bengaluru, Karnataka 560109

**Abstract**— Air pollution has been marked as one of the vital issues of metropolitan areas around the world and is an acute problem which leads to detrimental effects on human health and living conditions. Therefore, there is a need to monitor the pollution levels to inform people about the status of current air quality. This is done by an index called Air Quality Index (AQI) that maps the concentration of various pollutants into a single value. The analysis of pollution data often lacks transparency to outsiders, which may lead to wrong decisions regarding environmental regulations. This has led to a need for a tamper-proof pollution management system for use by authorities, like the state and central pollution boards. To address these challenges, a model using machine learning algorithms that can be used to predict the air quality and store that information in the blockchain is proposed. The use of Machine learning algorithms helps in determining the air quality category and that of blockchain technology ensures a permanent, tamper-proof record of all air quality data and such a solution could solve problems of data reliability that persist in pollution management.

**Keywords**— Air Quality Index(AQI), Distributed Ledger, Blockchain, Machine Learning(ML), Hyperledger Fabric(HLF)

## I. INTRODUCTION

The acceptability of air for breathing by humans, animals, and plants is measured by air quality. A healthy person inhales roughly 14,000 litres of air every day on average. As a result, poor air quality may have an impact on current and future generations' quality of life through harming health, the environment, the economy, and the liveability of cities.

Air pollution is defined as the presence of any air pollutant in the atmosphere. An air pollutant is a solid, liquid, or gaseous substance that exists in the atmosphere in amounts that are or tend to be hazardous to humans, other living creatures, plants, property, or the environment. The concentration of pollutants in the air, water, and soil that come from these emissions influences the magnitude of human exposures through organs such as the nose, mouth, and skin.

Therefore, monitoring of pollutants is important for effective air quality management. This is done by an index called Air Quality Index (AQI) that maps the concentration of various

pollutants into a single value. Each range of values have specific AQI categories as shown in Fig. 1.

The Government monitors air quality in different areas to find out how much pollution is in the air and make sure pollutant levels are meeting health - based air quality standards. Knowing how much pollution is in the air in a certain area helps air quality agencies know when and how to take action to protect public health.

| AQI Category, Pollutants and Health Breakpoints |  |                                       |                       |                      |          |                       |                       |
|---|--|---------------------------------------|-----------------------|----------------------|----------|-----------------------|-----------------------|
| AQI Category (Range)                            | PM <sub>2.5</sub> (µg/m <sup>3</sup> ) | PM <sub>10</sub> (µg/m <sup>3</sup> ) | NO <sub>2</sub> (ppb) | O <sub>3</sub> (ppb) | CO (ppm) | SO <sub>2</sub> (ppb) | KL <sub>1</sub> (ppb) |
| Good (0-50)                                     | 0-35                                   | 0-55                                  | 0-40                  | 0-10                 | 0-10     | 0-8                   | 0-20                  |
| Moderate (51-100)                               | 36-55                                  | 56-90                                 | 41-80                 | 11-20                | 11-20    | 4-8                   | 21-40                 |
| Unhealthy for Sensitive Groups (101-150)        | 56-75                                  | 91-135                                | 81-160                | 101-160              | 21-30    | 8-16                  | 41-80                 |
| Unhealthy (151-200)                             | 76-100                                 | 136-180                               | 161-320               | 161-200              | 31-40    | 16-32                 | 81-160                |
| Very Unhealthy (201-300)                        | 101-150                                | 181-270                               | 321-640               | 201-240              | 41-50    | 32-64                 | 161-320               |
| Hazardous (301-500)                             | 151-250                                | 271-405                               | 641-1280              | 241-300              | 51-70    | 64-128                | 321-640               |

Fig. 1. Air Quality Index(AQI) Category Range

The following are some of the reasons why the government employs air monitoring data: Determine whether or not the air quality meets national criteria. Determine the pollutant concentrations that are the highest. Validate pollution modelling, used to test 'what if' scenarios, and understand how pollutants behave and their relationship with the weather. Air quality forecasts, Assess the efficacy of air pollution reduction programmes. Examine the consequences of air pollution on public health. Follow the status of plans to satisfy the air quality requirement. Determine the current state of air quality. Develop pollution control tactics and policy decisions that are both responsible and cost-effective.

The current technique for tracking industrial pollution is centralised, with a lack of openness and the possibility of data falsification. As a result, a consistent and tamper-proof mechanism must be utilised, such as secure software with data encryption and simultaneous data transfer directly to the regulator. Using blockchain, this application seeks to accomplish this. Blockchain delivers Distributed ledger technology (DLT), which has the potential to solve many of the present system's open issues. Through a highly available and fault-tolerant infrastructure in which numerous storage and computing devices (referred to as blockchain nodes) replicate data, blockchain facilitates the operation of a distributed database that is transparent and tamper-resistant.

## II. REVIEW ON THE RELATED WORKS

# Driver Drowsiness Monitoring System using Visual Behavior and Machine Learning

Vaneeta M<sup>1</sup>, Vinayaka H N<sup>2</sup>

<sup>1</sup>Professor, Computer Science & Engineering

K.S.Institute Of Technology(VTU), Bengaluru, India

<sup>1</sup>vaneetam@ksit.edu.in

<sup>2</sup>Final Year MTech Student, Computer Science &  
Engineering K.S.Institute Of Technology(VTU),  
Bengaluru, India

<sup>2</sup>vinayakavinu08@gmail.com

**Abstract—** Driver drowsiness has become one of the major reasons of deadly road accidents that lead to serious physical injuries, loss of lives. Continuously driving for long hours without rest causes fatigue and consequently fatal road accidents. Intense workload on the drivers tends to make them work overtime. These long working hours make them fatigued which in turn makes them feel drowsy while driving. The major victims of this overburden are the truck drivers and bus drivers who drive non-stop throughout day and night. This imposes a major threat to a human life and as well as to the life of the passengers. To prevent deadly accidents or to warn drowsy driver just in time a reliable driver drowsiness detection system should be implemented, which would alert the driver before anything undesired happens. The measures that have been employed for drowsiness detection falls into three basic categories: physiological, behavioral and vehicle-based measures. The Haar cascade classifier proposed utilizes the 'behavioral' measure of the driver, that is, it works by interpreting the visual signs of the driver. The driver's facial appearance is captured via a camera installed in the car. The aim of this is to develop a prototype drowsiness detection system. The focus will be placed on designing a system that will accurately monitor the open or closed state of the driver's eyes in real-time. By monitoring the eyes, it is believed that the symptoms of driver fatigue can be detected early enough to avoid a car accident.

## I. INTRODUCTION

Drowsiness is a big problem that concerns road safety and causes severe bodily and sometimes mental harm to human life as well as economic progress, claiming the lives of thousands of individuals every year. Due to sleepiness or exhaustion, a substantial number of accidents occur across

the globe. To describe drowsiness, one must observe an increase in awareness position and a tendency to fall asleep. As a result of this presence while driving, the motorist is unable to take any preventative measures, such as swerving off the road.

Department of CSE, K S Institute of Technology, Bengaluru

Drivers are more likely to work extra if they have a heavy workload. They are tired from working long hours, which makes them sleepy while driving. Truck and bus drivers are the primary victims of this overload, since they travel nonstop throughout the day and night. This puts his or her life, as well as the lives of the other passengers, in grave danger.

Hundreds of thousands of tragedies are linked to this magnificent technology every year because of our indifference to our responsibilities. The significance of adhering to traffic laws may go unnoticed by most people, yet it cannot be underestimated. The automobile is the most powerful tool on the road, and it may be deadly in the hands of those who abuse its power. This recklessness can even endanger the lives of others who share the road with the vehicle. When we refuse to confess when we're too exhausted to drive, we're engaging in a kind of recklessness.

Road accident is a global tragedy with number of cases increasing year by year. Owing to the bad infrastructure and dangerous driving habits, Most deaths around 105,000 per year occur in India. Around 20 percent of traffic accidents and up to 25 percent of serious accidents occur because of Driver's diminished vigilance. The increasing number of accidents due to a drivers vigilance level diminishing has become a grave problem for us.

The algorithm is coded on OpenCV platform in Linux environment. The parameters considered to detect drowsiness are face and eye detection, blinking, eye closure and head tilt. The algorithm is Haar trained to detect the face. Once the face is detected, the facial landmarks position around the eyes is determined. The mean eye landmarks distance is calculated and thus the eye state is determined from that distance. Eyelid closure/blink/gaze is detected using the values obtained from each of the incoming frames.



# Visualizing And Forecasting Stocks Using DASH

Dr, Vijayalaxmi Mekali <sup>1</sup>, Mahesh B V <sup>2</sup>, Manikonda Tharun <sup>3</sup>, L Sharandeeep Chowdary <sup>4</sup>

<sup>1</sup>Associate Professor, <sup>2,3,4</sup> Under Graduate Student

Dept of Computer Science and Engineering,  
K S Institute of Technology,  
Bengaluru, Karnataka

**ABSTRACT:** In the money world stock exchanging is one of the most significant exercises. Stock exchange forecast is a demonstration of attempting to decide the future estimation of a stock. This paper clarifies the forecast of stock utilizing machine learning. The specialized and major or the time arrangement examination is utilized by the majority of the stockbrokers while making the stock predictions. The programming language is utilized to foresee the financial exchange utilizing AI in Python. Right now, we propose a Machine Learning (ML) approach that will be trained from the accessible stock's information for a precise prediction. Right now, study utilizes an AI procedure called Long Short-Term Memory (LSTM) Algorithm to foresee stock costs

**Keywords:** Stock Market, Machine learning, Predictions, LSTM.

## I. INTRODUCTION

These days, as the associations between overall economies are fixed by globalization, outer aggravations to the money related markets are never again residential. With developing capital markets, an ever-increasing number of information is being made day by day.

The inherent estimation of an organization's stock is the worth controlled by assessing the normal future incomes of a stock and limiting them to the present, which is known as the book value. This is different from the market estimation of stock that is controlled by the organization's stock cost.

Investing in the stock market is among the common ways investors attempt to grow their money, but it's also among the riskier investment options available. Understanding the basic concept of the stock market is the first step in becoming an informed investor. While the stock market is an extremely complex system, its basic traits are much simpler.

In this approach, with the use of supervised learning classifier to predict stock price movement based on financial index report and evaluate their potency is proposed. Statistical analytic methods in financial market have become stock marketing. Here in this paper, we used Long short-term memory Algorithm. We tried to use different types of features and kernels in order to achieve the results. We took the Data Set from Kaggle an online data set provider.

We took the Data set of Apple company which works in electronics, computer software and online services. By splitting the data in various ways, we tried to minimize the loss as possible. We also added our features to increase the accuracy of the training model.

## II. LITERATURE SURVEY

[1] Ashish Sharma, Dinesh Bhuriya, Upendra Singh proposed stock market prediction has become an increasingly important issue in the present time. One of the methods employed is technical analysis, but such methods do not always yield accurate results. So it is important to develop methods for a more accurate predictions that are obtained from the stock price after considering all the factors that might affect it. The technique that was employed that was employed in this instance was a regression. Since financial stock marks generate enormous amounts of data at any given time a great volume of data needs to undergo analysis before a prediction can be made. Each of the techniques listed under regression habits own advantages and limitations over its other counterparts. One of the noteworthy techniques that were mentioned was linear regression. The way linear regression models work is that they may alternatively also be fitted in other ways, such as by diminishing the "lack of fit" in some other norm, or by diminishing a handclapped version of the least square's loss function. Conversely, the least squares approach can be utilized to fit nonlinear model<sup>5</sup>.

[2] K.Hiba Sadia, Aditya Sharma, Adarsh Paul, SarmsthaPadhi proposed a stock prediction using few classifiers includes the Random Forest Classifier, SVM Classifier. The outcome of the paper is to sum it up, the accuracy of the SCM Model to Test Set is 0.787 whereas the Random Forest Classifier is calculated to 0.808

[3] Ashutosh Sharma, Sanket Modek, Eashwaran Sridhar published the Data Visualization and Stock Market and Prediction paper in IRJET. In the paper they compared the benchmark model- Linear regression to the final improved LSTM Model, Mean Squared Error. Output graph showing the pattern prediction by LSTM model and the actual pattern observed in the dataset of closing price.

[4] V Kranthi Sai Reddy proposed the paper on Stock Market Prediction using ML in IRJET Journal. In this paper the prediction of stock market is done by the Support Vector Machine (SVM), Radial Basis Function (RBF). The model generates higher profit compared to the selected benchmarks. SVM does not give over fitting and results are highly efficiency.

[5] Stock Market Prediction via Multiple Source Multiple Instance

# Detection and Segmentation of Corona Virus Infected Region of Lung in CT images by using Deep learning approach

Dr, Vijayalaxmi Mekali <sup>1</sup>, Chaitra .K <sup>2</sup>, Megha Shree . A <sup>3</sup>, Lavanya .C R <sup>4</sup>, Bhoomika .H <sup>5</sup>

<sup>1</sup> Associate Professor, <sup>2,3,4</sup> Under Graduate Student

Dept of Computer Science and Engineering,  
K S Institute of Technology,  
Bengaluru, Karnataka

**ABSTRACT:** This research presents an application of lung segmentation of an internal organ from Computed Tomography images using an artificial intelligence development approach. The deep convolutional neural network was used to perform semantic segmentation of an internal organ by training through different Computed Tomography image slices with a medical dataset that has abnormal physiology. Coronavirus disease infected on the lung datasets were used as a study in this research with adjusted deep fully convolutional neural network compared with an architecture of U-Net model that was used to implement the experimental process. However, this research will aim to develop a deep learning model as an image processing to use with medical image data to reduce the time in a part of treatment planning. The proposed model is developed to provide accurate diagnostics for binary classification (COVID vs. No-Findings) and multi-class classification (COVID vs. No-Findings vs. Pneumonia). Our model produced a classification accuracy of 98.08% for binary classes and 87.02% for multi-class cases.

**KEYWORDS:** Deep learning, Image Segmentation, Computational modelling, Computed Tomography, Lung, Convolutional Neural Networks

## I. INTRODUCTION

COVID-19 presentation, which began with the reporting of unknown causes of pneumonia has rapidly become a pandemic. The most common test technique currently used for COVID-19 diagnosis is a Real-Time Reverse Transcription-Polymerase Chain Reaction (RT-PCR). We are aiming to design a Non-Contact method and breaking human intervention like swab collection or testing in a short period of time. Chest Radiological Imaging such as Computed Tomography (CT-Scans) have vital roles in early diagnosis and treatment of this disease. Doctors diagnose based on clinical and chest CT results, CT Scan is widely used for COVID-19 detection.

## II. MOTIVATION

An outbreak of a novel coronavirus disease (i.e., COVID-19) has been recorded in Wuhan, China since late December 2019, which subsequently became pandemic around the world. Although COVID-19 is an acutely treated disease, it can also be fatal with a risk of fatality of 4.03% in China and the highest of 13.04% in Algeria and 12.67% Italy (as of 8th April 2020). The onset of serious illness may result in death as a consequence of substantial damage and progressive respiratory failure. Although laboratory testing, e.g., using reverse transcription polymerase chain reaction (RT-PCR), is the golden standard for clinical diagnosis, the tests may produce false negatives. Moreover, under the pandemic situation, shortage of RT-PCR testing resources may also delay the following clinical decision and treatment. Under such circumstances, chest CT Scan imaging has become a valuable tool for both diagnosis and prognosis of COVID-19 patients.

## III. LITRATURE SURVEY

[1] Siti Raihanah Abdani ; Mohd Asyraf Zulkifley ; Nuraisyah Hani Zulkifley in the study " A Lightweight Deep Learning Model for COVID-19 Detection" which was based on 14 layers of CNN with a modified Spatial Pyramid Pooling model. This network allows to identify the covid 19 disease for various severity levels. SPP- Covid -Net achieves the best mean accuracy. The implementation was easy in this paper.

[2] João O. B. Diniz, Darlan B. P. Quintanilha "Segmentation and quantification of COVID-19 infections using pulmonary vessels extraction and deep learning". In this study the aim was to automatically segment infections caused by covid 19 and provide quantitative measures of these infections to specialists thus serving as a special tool using pulmonary vessel extraction .

[3] Aboul Ella Hassanien, Hassan Aboul-

# PEOPLE FOLLOWING TROLLEY

1 Mr.Sanjoy Das, 2 Rushi CS, 3 Kalpitha AJ, 4 Arpitha G, 5 Golla Yaswanth.

1 Assistant professor, 2,3,4,5 Undergraduates,

Dept of Computer Science and Engineering, K S Institute of Technology, Raghuvanahalli,  
Bengaluru, Karnataka.

**Abstract:** The smart shopping trolley system helps customers while shopping. The trolley has an automatic billing system and it follows the movement commands provided by the user by using hand gesture. An android application is installed in customers mobile. The products purchased by the customer and their cost will be automatically updated to the android application through internet and that bill will automatically send to the billing counter system in the shop. This helps customer by replacing tedious process of pulling and pushing the trolley and saves time spent in the billing counter. The Automated Shopping Trolley is a Smart Trolley which integrates with ultrasonic sensor, arduino, wifi module, weigh sensor in it. The scanned items by the customer using mobile app which will automatically log into the shopping cart and thereby can generate bill for items selected. These modules are integrated into an IoT system and are tested to satisfy the functionality.

**INDEX TERMS:** IoT, Bluetooth, Barcode Scanners, Obstacle avoidance, Android application

## I. INTRODUCTION

Commonly as in vogue of now, shopping has become an integral part of today's society. We can see a huge rush at the mall and supermarkets during weekends, holidays and sales. A major concern for the customer at the mall and supermarket occur when there is a long waiting queue at the billing counter. The customer tends to leave the queue rather than standing for hours at the billing counter this turns out to be a trouble for the mall and supermarket owner. So, the automated shopping trolley which comes together with a bar code scanner and a touch screen display is designed which would help the customer to pay for their goods in the mall and supermarket without being served by a sales associate. Every product in the supermarket will have a bar code the customer will pick the product scan the barcode with the help of barcode scanner attached to the shopping trolley. After scanning the barcode, the concept is designed into a smaller version of the automated self-checkout system on a shopping trolley with a user interface screen which allows customers to

make payment for items scanned and placed in the trolley before leaving the entrance of the store. This is to release pressure during peak hours. The Smart Trolley comes with all the traditional services including scanning an item to check for price and details, also there are other additional features that will be included in the design such as locating an item in the store by typing in the item's name in the search field on the user interface screen which will automatically show the item's location and also we can set the budget. The Smart Trolley is designed with security measures to prevent it being wheeled out from the store's premises and also to protect customer's card details as it is designed to accept only card payment for items bought in the store. The details and the price of the product will be displayed on the touch screen display along with the total bill of the items purchased. This system would also be beneficial for the customer with a certain budget limit and saves long waiting time at the billing counter. In this project, we seem it fit to propose the "Intelligent Shopping Basket" which aims to reduce ,and possibly eliminate the total waiting time of customers, lower the total manpower requirement and expenses for markets and increases

# PROTECTION OF FOREST TREES AGAINST POACHING BASED ON IOT

Mr. Roopesh Kumar B N 1, Vijay N S 2, Pullur Pavan Kumar 3, Nitish Kumar M R 4, Sandeep Kumar 5

1 Assistant Professor, 2,3,4,5 Under Graduate Students  
Dept of Computer Science and Engineering, K S Institute of Technology,  
Bengaluru, Karnataka.

**Abstract:-** All around the world there are numerous occurrence about stealing of trees like sandal, sagwan, timber etc. These trees are expensive and pitiful. They are utilized in medicine, beautifying agent, furniture etc. To limit their sneaking and to spare woodland around the world some preventive estimates should be conveyed and sometimes in forest, fire broke out which cause destruction to wildlife animal and also tree so it is necessary to control fire as soon as possible. Because of huge amount of money involved in selling of such trees lot of incidents are happening of cutting of trees. In this context we are supposed to provide a protection to the trees which can be used to restrict this smuggling. The purpose of this project is to save valuable trees which have high demand in market like teak, sandalwood, etc.

**Keywords:-** Trees, sandal, timber, smuggling.

## I. INTRODUCTION

- In recent years poaching or smuggling of environmentally and economically important species of trees in forested areas- such as Sandalwood, Teakwood, Pine and Rosewood has been tremendously increased.
- There have been several initiatives undertaken by different stakeholders-- and in particular – by the Govt. of India, to mitigate these problems.
- The main idea presented in this paper is to design a portable wireless sensor node which is a part of wireless sensor Network.
- It will be mounted on trunk of each tree, capable of detecting theft as well as automatically initiate & send alarm signals if any to remote terminal through wireless media.

The implementation of a real time, wireless sensor network and data logging system which will be a sophisticated and a cheap modern technology to make monitoring more robust, effective and feasible. WSN is a most emerging technology, widely used in many industrial applications such as monitoring, maintenance, security and control application, specific in remote monitoring applications etc. In forest areas, WSN are widely used for fire detection in forest, to detect poaching of trees, for environmental monitoring, etc.

## II. LITERATURE SURVEY

- [1] Anti-Poaching of Trees in Forest-Based on IoT. In this Paper suggests gyro sensor to detect the inclination of the tree which are being cut.

- [2] Preventive System for Forests. In this paper suggests to use Flex Sensor, Micro Controller To detect the bending of tree Every tree will be equipped with electronics unit consists of Micro Controller, Flex Sensor and ZigBee module. There will be one sub server unit for area.
- [3] Forest protection using wireless sensor network and IoT. In this paper it uses a video monitoring with raspberry pi to detect forest fire.
- [4] An IoT based fire alarming and authentication system for workhouse using Raspberry Pi 3. In this paper Raspberry Pi 3 id used to control multiple Arduino integrated with sensors like light intensity sensor, gas smoke sensor and camera.
- [5] IOT enabled forest fire detection and online monitoring system. In this paper it uses various sensors like lm 35 sensor to temperature, smoke and fire sensors with raspberry pi module.
- [6] Handover based spectrum allocation in cognitive radio networks. In this paper the capacity of the cognitive radio network is maximized by coordinating SUs handover decision optimally in the PU-SU coexisted cognitive radio networks.
- [7] Implementation of a Forest Monitoring and Alerting System. In this paper it uses the sensors accelerometer, tilt sensor, sound sensor and temperature-humidity sensor should extract accurate readings from the surroundings.
- [8] Preventive system for forests property using wireless communication. In this paper it uses the Sensors used are PIR, Flex , Force Sensitive Resistor and Signal Conditioner.
- [9] Zigbee Based Intelligent Forest Monitoring System Using Wireless Sensor Network. In this paper we have implemented a portable device based on Zigbee wireless sensor network for forest monitoring.

## III. METHODOLOGY

# A Survey on Credit Card Fraud Detection

Mr. Roopesh Kumar BN<sup>1</sup>, Bhagyashree V<sup>2</sup>, Bi Bi Ayesha<sup>3</sup>, Likitha S<sup>4</sup>, Shalini KP<sup>5</sup>

<sup>1</sup>Assistant professor & Head, Computer Science & Engineering

K.S.Institute Of Technology(VTU), Bangaluru, India

<sup>1</sup>roopeshkumarbn@ksit.edu.in

<sup>2,3,4,5</sup>Final Year Student, Computer Science & Engineering

K.S.Institute Of Technology(VTU), Bangaluru, India

<sup>2</sup>bhagyamohan3@gmail.com

<sup>3</sup>aishakulsum0404@gmail.com

<sup>4</sup>likitha6065@gmail.com

<sup>5</sup>shalinikp96@gmail.com

**Abstract**— Electronic commerce technology has advanced tremendously in recent years, and as a result, the use of credit cards has expanded considerably. As mastercard becomes the most widely used method of payment for both online and offline purchases, incidences of fraud involving it are on the rise. We offer the required theory for detecting fraud in mastercard transaction processing using a Hidden Markov Model in this work (HMM). The traditional behaviour of a cardholder is used to teach an HMM at first. An incoming credit card transaction is considered fraudulent if the trained HMM does not accept it with a high enough probability. At the same time, we use an enhancement to ensure that valid transactions are not denied (Hybrid model). In subsequent sections, In further sections we compare different models and methods for fraud detection and prove that why HMM is more preferred method than other methods.

**Keywords**— Credit card, Electronic commerce, Fraud detection, Genetic algorithms.

## I. INTRODUCTION

Credit cards are widely accepted around the world today, and organisations of all sizes are storing data in large quantities, in a wide variety of formats, at rapid speeds, and for a high value. This information is acquired from a variety of sources, including user purchase habits and social media followers, likes, and comments. All of this information was analysed and visualised to reveal the hidden data pattern. In the early stages of credit card analysis, general public databases, biometrics, and financial analyses were utilised. Credit cards are an easy and friendly target for fraudsters since a huge number of money may be obtained fast and without risk. In order to perpetrate credit card fraud, fraudsters seek to steal sensitive information such as credit card numbers, bank account numbers, and social security numbers. Because hackers try to make every fraudulent transaction appear legitimate, detecting fraud is challenging. Over 70% of consumers in the United States are vulnerable to fraudulent transactions, according to an increase in credit card transactions. Basically, Because there are usually more valid transactions than fraudulent transactions, the credit card dataset is considerably skewed. That is, it predictions with a high degree of accuracy while avoiding detecting a fraudulent transaction. A better way to address this type of problem is class

distribution, which is a sample of minority classes. A class training example can be utilised to boost the algorithm's chances of producing a correct prediction while sampling the minority.

## II. FRAUD DETECTION SYSTEM

By reducing redundant data and separating data into training and test sets, fraud and genuine transactions can be detected. Credit card fraud is detected in real time using topological intelligence. Credit card fraud is detected using the Markov Model and Logistics Regression. We create a web application to read input and display output. The goal is to locate each and every fraudulent transaction. Because fraudulent credit card transactions account for a small percentage of total transactions, the system should be able to survive skewed distributions.

TABLE I  
INPUT ATTRIBUTES

| Input attribute                            | Example of attribute value |
|--|----------------------------|
| Message type                               | 1031                       |
| Type of transaction                        | 700                        |
| Network identification                     | 25                         |
| Day of registration in system              | 2                          |
| Time of registration in system(In minutes) | 720                        |
| Day of registration in device              | 1                          |
| Time of registration in device(in minutes) | 730                        |
| Amount of transaction                      | 1000                       |
| Currency of transaction                    | 840                        |
| Terminal type                              | 1                          |
| Language code( for ATM only)               | 7                          |
| Acquirer institution identification        | 109428                     |
| Acquirer institution country code          | 643                        |
| Merchant identification                    | 456783                     |

# Forest Fire Susceptibility using Neural Network

Amaravathi M<sup>1</sup>, Chandan Kumar<sup>2</sup>, Likhitha N<sup>3</sup>, Nandini J K<sup>4</sup>, Kumar K<sup>5</sup>

Computer Science and Engineering<sup>1,2,3,4,5</sup>, K S Institute of Technology<sup>1,2,3,4,5</sup>

[amaravathil57@gmail.com](mailto:amaravathil57@gmail.com)<sup>1</sup>

[chandankumar6070@gmail.com](mailto:chandankumar6070@gmail.com)<sup>2</sup>

[likhitha.n2135@gmail.com](mailto:likhitha.n2135@gmail.com)<sup>3</sup>

[nandini.jk456@gmail.com](mailto:nandini.jk456@gmail.com)<sup>4</sup>

[kumark@ksit.edu.in](mailto:kumark@ksit.edu.in)<sup>5</sup>

**Abstract**— Forest fires have impacted negatively on ecosystems, cultures, and economies all across the world. Modeling and anticipating the incidence of wild fires are essential to minimize these damages and reducing forest fires because they can help with forest fire prevention strategies. The convolutional neural network (CNN) has emerged as a key state-of-the-art deep learning method in recent years, and its application has enriched a wide range of fields. As a result, we proposed a CNN-based spatial prediction model for forest fire susceptibility. The concept is that this model is used to identify a fire or the beginning of a fire in a forest using (aerial) surveillance data. In the event of a fire, the model might be applied in real time to low-framerate surveillance video or picture and provide a warning. The network will be trained on a dataset that includes images in three categories: 'fire,' 'no fire,' and 'smoke'. The majority of the photographs will be of forests or forest-like situations. Photos labelled 'fire' have visible flames, while images labelled 'smoke' have smoke sensing the smoke. Finally, photographs with the title 'no fire' were taken in forests. We will leverage the data augmentation function offered by Keras (Python Deep Learning API) to conduct a series of random transformations on photos before feeding them to the network in order to train a network that generalizes well to new images. Finally, our goal is to create a legible project which handles every aspect of CNN creation and training. Early detection of fire in the forest is very helpful and our biodiversity can be saved.

**Keywords**— Introduction, Literature Survey, Methodology including CNN architecture, Conclusion and References.

## I. INTRODUCTION

A forest fire is a phenomenon that can be defined as an accidental fire in a flammable vegetation region. They have the potential to cause plenty of environmental disasters, as well as significant economic and ecological damages. Forest fire surveillance and tracking have become an important method for preventing this, attracting increasing interest throughout the world. Massive forest fires occurred in a number of locations across India's Karnataka state's Bandipur National Park in February 2019. The Indian Space Research Organization's (ISRO) National Remote Sensing Centre conducted an estimate of the total area damaged by the fire. On February 25, 2019, was projected that the burned area had grown to around 10,920 acres in the five days since February 21, 2019. Because regional forest fire susceptibility is typically influenced by a variety of factors and has typical nonlinear and complex properties,

developing accurate forest fire prediction models remains a challenge. For predicting forest fire susceptibility, a variety of methodologies have been proposed, ranging from physics-based methodologies to statistical and machine learning (ML) techniques. ML algorithms have demonstrated the capacity to deliver superior results for the geographical forecast of wildfires when compared to standard qualitative and statistical analytic methodologies. Artificial neural networks, random forests (RF), support vector machine (SVM), multilayer perceptron neural network (MLP), kernel logistic regression (KLR), naive Bayes, and gradient descent trees are just a few of the machine learning algorithms that have already been successfully developed and commonly used to create wildfire susceptibility visualizations.

Deep learning (DL) techniques have lately gotten a lot of attention and have had a lot of success. Deep learning techniques are widely used in domains such as object identification and detection, audio recognition, and natural language processing because they aim to uncover numerous representation levels. In recent studies in areas such as disaster damage detection, remotely sensed image classification, and landslide susceptibility mapping, the convolutional neural network (CNN) has been recognized as one of the most effective and commonly used DL algorithms, which has generated major improvements.

The CNN can fully utilize contextual information and identify several layers of representations from input data, making it better suited to the evolution of fire event spatial features. The DL method shows deep characteristics and may differentiate between geographical entities. As a result, examining the use of the CNN algorithm in forest fire susceptibility assessments has some practical value. The likelihood assessment of fire occurrence in a region is characterized as forest fire susceptibility in this article. The major goal of this research is to use contextual-based CNNs with deep architectures to forecast regional forest fire susceptibility spatially. The forest fire susceptibility model is built using a CNN, and the model's hyperparameters were tuned to increase predictive accuracy.

## II. LITERATURE SURVEY

# A Botnet Attack Detection Model using Machine Learning Techniques

Mr. Kushal Kumar B N<sup>1</sup>, Fariya N<sup>2</sup>, Monika K C<sup>3</sup>, Chaithra R<sup>4</sup>

<sup>1</sup> Assistant Professor, <sup>2,3,4</sup> Undergraduate Student

Dept of Computer Science and Engineering,  
K S Institute of Technology,

Bengaluru, Karnataka

**Abstract**— With the rapid growth in the usage of IoT connected devices in various industries like the consumer market in home automation, energy management, automobiles and many more. This has led to the IoT devices getting targeted by malicious attackers trying to hack the system. To deal with this there should be Detection models that help if any attack has occurred, and corresponding action can be taken. We are using the Bot-IoT 2018 dataset is selected, where we are utilizing feature extraction so that we consider only important and just enough features that will help us to classify the attack. Various Machine Learning Algorithms have been used to train the dataset to achieve a high accuracy model. A real-time DDoS attack was simulated using the hping3 tool and tested in the prediction model.

**Keywords**— Bot-IoT 2018 dataset, Feature Extraction, Machine Learning Algorithms, DDoS-Distributed Denial of Service

## I. INTRODUCTION

In today's world, everything is inter-connected with network. Computers on one network can interact and connect with computers on various network. This connection allows the end users to exchange messages amongst each other, to communicate with other systems, to access various computer related benefits and to solve real life problems. Since network allows users to interact among computers, there is chance for cyberattacks to take place. These attacks are dangerous and causes certain hacking related problems such as crashing the user's important data, taking out the wanted information and replacing it with the corrupted file, accessing user's personal information and sending bot files.

Cyber criminals are the ones who creates cyber-attacks using single or more computers using the network which makes the computer disabled, corrupts the information, or uses a rift system as a start point for other attacks. These attacks are performed by using various methods such as malware, DoS (Denial of Service), phishing etc.

A series of networked computers diseased with the malicious software controlled by bot header is known as botnet. The bot header monitors the infrastructure of botnet and handles the system to design attacks to destroy and crash the targeted network. A bot is a single device within the botnet networking. We are developing a detection model in order to detect various attacks that could happen.

## II. LITERATURE SURVEY

[1] In this paper they aim to develop a lightweight intrusion detection system for which they are finding optimal feature pairs in the dataset. They use the Bot-IoT dataset and ten machine learning algorithms. The 12 best features were used which was recommended by the developers of this dataset. Using the 12 best features 66 new unique feature pairs were generated. By training the 10 machine learning algorithms with the 12 full features, 10 feature-based IDSs were created. Continually, 660 feature-based lightweight IDSs were developed by training with the machine learning algorithms. Then after the comparison, the 10 full-feature-based IDS was chosen. With this approach, an accuracy of 90% is obtained.

[2] In this study, a hybrid deep learning technique combining a convolutional neural network and a long short-term memory (CNN-LSTM) algorithm was suggested to detect botnet assaults on nine commercial IoT devices, specifically BASHLITE and Mirai. A real N-BalIoT dataset retrieved from a real system was used to conduct extensive empirical study, which included both benign and harmful patterns. The model outperformed the proposed system to detect botnet attacks, with accuracy of 90% and 88.61%, although the suggested system had good accuracy 88.53% in detecting botnet attacks from thermostat devices. CNN-LSTM model was successful in obtaining good accuracy.

[3] This paper presents an approach using Convolutional Neural Networks (CNN) for Intrusion detection systems (IDS) that utilizes benefit of the power of IoT and investigate whole traffic throughout the IoT. The suggested model demonstrates the capacity to detect any potential intrusion as well as aberrant traffic patterns. Using the NID Dataset and the

# Diabetes Prediction Using Different Machine Learning Approaches

Kushal Kumar B N<sup>[1]</sup>, R Ramya<sup>[2]</sup>, Vedavedya B H<sup>[3]</sup>, Veera Sreenidhi<sup>[4]</sup>, Venkatesh M N<sup>[5]</sup>

<sup>1</sup> Associate Professor, <sup>2,3,4,5</sup> Undergraduates

<sup>1</sup>Department of Computer Science and Engineering,

<sup>1</sup>K S Institute of Technology, Bangalore, India

[kushalkumarbn@ksit.edu.in](mailto:kushalkumarbn@ksit.edu.in) [ramyareddy9488@gmail.com](mailto:ramyareddy9488@gmail.com)  
[vedavedyabh@gmail.com](mailto:vedavedyabh@gmail.com) [veerasreenidhi@gmail.com](mailto:veerasreenidhi@gmail.com)  
[venkateshmnvenki@gmail.com](mailto:venkateshmnvenki@gmail.com)

**Abstract**—Diabetes is an illness that is caused by a hormone called insulin in our body which when not functioning properly or not efficiently will raise the level of glucose in our body. There are many individuals who suffer from high blood sugar levels in their body which has a severe effect on other human organs. This condition is caused by an unhealthy lifestyle or food habits and lack of physical exercise. This will also lead to other complications such as coronary failure, blindness, urinary organ disease, etc. In such instances, the individual must visit a diagnostic center to collect their reports. Due to this, there is a loss of time and money in this process. As a solution for this problem, we can use Machine Learning methods to arrive at a solution to this issue, we have got advanced system mistreatment information processing that has got the potential to inform us whether the individual has got the disease or not. In addition to this, an early prediction of this disease will help in controlling it as well as be able to take precautions for its after-effects. Information withdrawal has the pliability to delete unseen data from a large dataset of diabetes information. The aim of our project is to predict illness in its early stages with better accuracy so that the risk factor is comparatively less. The model is based on methods such as Random Forest, XG Boost, ADA boost and DNN classifier algorithms.

**Keywords**— Diabetes Disease Prediction, Random Forest, XG Boost, ADA boost and DNN classifier

## I. INTRODUCTION

Diabetes is one of the deadliest diseases in the world. It is not solely a malady however conjointly a creator of various sorts of diseases like heart failure, blindness etc. The conventional distinguishing method is that patients ought to visit a diagnostic center, consult their doctor, and rest for each day or additional to induce their reports. Moreover, whenever they need to induce their diagnosing report, they need to waste their cash vainly. There are of two different types of diabetes that can be classified into Type one polygenic

disorder is that the kind wherever the exocrine gland doesn't manufacture hypoglycaemic agent. It had been erstwhile mentioned as endocrine dependent polygenic disorder or autoimmune disorder. Simple fraction of sufferers has this kind, individuals with this kind should acquire an artificial kind of endocrine they either receive it from an attempt or from associate degree endocrine pump. Diabetes Mellitus (DM) is formed public as a gaggle of metabolic disorders primarily caused by abnormal hypoglycaemic agent secretion and or action. Hypoglycaemic agent deficiency finally ends up in elevated blood glucose levels (hyperglycaemia) and impaired metabolism of carbohydrates fat and proteins. DM is one altogether the foremost common endocrine disorders moving quite two hundred million folks worldwide. The onset of polygenic disorder. The onset of polygenic disorder is calculable to rise, dramatically within the approaching year. In sort a pair of polygenic disorder the duct gland will create endocrine this way was antecedent named non-insulin dependent DM or non-insulin-dependent diabetes. However, it should not turn out enough. In different cases, the body doesn't use it properly. This can be called endocrine resistance folks with sort a pair of polygenic disorder may have to require polygenic disorder pills or endocrine. In inherited disease somebody usually suffers from high blood sugar Intensify thirst, intensify hunger and frequent evacuation of variety of the symptoms caused due to high glucose many complications occur if inherited disorder remains untreated.

Diabetes is divided into three main categories type 1, type 2 and gestational diabetes causes serious health concerns if it is not taken care properly. Type 1 diabetes was known insulin-dependent, childhood-onset or juvenile is characterized by body produce less insulin. People with type 1 diabetes require administration daily for insulin regulation of glucose in their blood. The person who has type 1 diabetes they cannot survive if they don't have access to insulin. Type 1 diabetes currently is not preventable because the causes is still unknown. Symptoms like weight loss, excessive urination fatigue, vision changes, and thirst can indicate the type 1 diabetes. Type 2 diabetes also was known as



# COMPy: SCIENTIFIC COMPUTING GETS BETTER

Kushal Kumar B. N  
Assistant Professor  
Dept. of Computer Science  
K. S Institute of Technology  
Bengaluru, Karnataka  
[kushalkumarbn@ksit.edu.in](mailto:kushalkumarbn@ksit.edu.in)

B R Gagan  
B. E Student  
Dept. of Computer Science  
K. S Institute of Technology  
Bengaluru, Karnataka  
[gaganravi1104@gmail.com](mailto:gaganravi1104@gmail.com)

Shivaprakash T  
B. E Student  
Dept. of Computer Science  
K. S Institute of Technology  
Bengaluru, Karnataka  
[shivaprakash.t.murthy@gmail.com](mailto:shivaprakash.t.murthy@gmail.com)

Thirumalai Shaktivel C  
B. E Student  
Dept. of Computer Science  
K. S Institute of Technology  
Bengaluru, Karnataka  
[thirumalaishaktivel@gmail.com](mailto:thirumalaishaktivel@gmail.com)

Vaishak P  
B. E Student  
Dept. of Computer Science  
K. S Institute of Technology  
Bengaluru, Karnataka  
[vaishak.puttaswamy@gmail.com](mailto:vaishak.puttaswamy@gmail.com)

**Abstract**—Scientific computing is a branch of computer science that focuses on understanding and solving complicated questions. It is a multidisciplinary field of study that entails the creation of models and simulations to better understand natural systems. However, just a few programming languages are specialized in numerical and scientific computations. Popular languages like Python, despite having performance issues; most people when asked to choose a language, chose an easier-to-understand language (Python) over domain-specific languages. To address Python's performance issue, the Python community has created tools such as Cython, Numba, Pythran, and others that can be used to speed up Python. Hence there is a need for a domain-specific language, which will be easy to understand and have good performance for the Scientific computing domain. This paper is a study about designing a new compiled language called 'ComPy-Lang', which incorporates the above-mentioned attributes. This paper also talks about, ComPy-Lang's compiler design, its features, implementation, and benchmark.

**Keywords**—scientific computation, compiler, programming language

## I. INTRODUCTION

Scientific computing is a multidisciplinary domain that combines Computer Science, Applied Mathematics, and Engineering. Along with "theory" and "experiment", Scientific Computing has emerged as the "third technique" for tackling basic scientific concerns. Many new researchers have joined in recent decades and are eager to contribute with their ideas. Researchers working in computational science generally encounter a difficulty i.e., primarily they have to concentrate on procedures like implementing, experimenting, and extracting information for solving the problem. At the same time, they have to convert this idea into programs that include implementation, testing, and debugging. While converting their problems into programs they should also concentrate on optimizing the program which is a time-consuming process. This suggests that an optimized high-performance computing language is required to assist researchers.

Why create a new language? For researchers to express their views better, they can make use of a programming language. A programming language will also help solve larger problems by performing many calculations for the researcher. Now, some programming languages for scientific computing do exist, but come with their own flaws. And

hence this paper proposes a new, better, domain-specific programming language for Scientific Computing.

To design a new language, it is advisable to first read prior works on language design and compiler design. Some of the papers referred include, [1] "The Design and Implementation of the Wolfram Language Compiler" [2] "An ELI-to-C Compiler: Design, Implementation, and Performance" [3] "Seq: A High-Performance Language for Bioinformatics", etc. All the papers referred suggest their own methods of implementation to improve performance for their respective languages. And most of the programming languages examined use LLVM as a backend, which can be used for both code generation and optimization.

ComPy-Lang is a new domain-specific programming language, which has been designed to help the community of Scientific Computing. To be a better programming language than the currently existing ones, ComPy-Lang comes with features like simple and understandable syntax, better performance than similar languages, and easy-to-understand error messages. The ComPy compiler is an 'Ahead-of-time' compiler. It is designed using the tools that are made for programming languages with a focus on speedy compilation and generating fast code. ComPy also includes runtime libraries to assist in numerical computations.

From the papers referred for designing a new programming language, it is clear that a compiler should be designed first; A compiler and not an interpreter because compilers in general have faster execution speed than interpreters. For designing a compiler, the phases of compiler design have been followed: Lexical analysis (re2c [8]), syntax analysis (GNU Bison [5]), semantic analysis, etc. The Libasr library [7] is used at the backend for optimizations and code generation. More details about these phases are mentioned in the implementation section below.

## II. LITERATURE SURVEY

Abdul Dakkak, Tom Wickham-Jones, et al., [1] proposed "The Design and Implementation of the Wolfram Language Compiler". The paper discusses the methods of building a production compiler for the wolfram programming language. The wolfram language already had a working compiler, but the goal of this paper was to provide one which was better than the existing wolfram compiler. While designing the compiler the paper also mentions the

# RICE LEAF DISEASE DETECTION USING DEEP LEARNING TECHNIQUES

Mr Kumar K<sup>1</sup>, Lokesh R<sup>2</sup>, Madhusudhan S R<sup>3</sup>, Mikkin K M<sup>4</sup>, Nagarjun N<sup>5</sup>

<sup>1</sup> Assistant Professor, <sup>2,3,4,5</sup> Under Graduate Student  
Dept of Computer Science and Engineering,  
K S Institute of Technology,  
Bengaluru, Karnataka.

**Abstract :** Rice is considered as one of the most important crops in India, rice crop is much vulnerable to illness. The disease that presents on plant leaves can be fungal disease, bacterial diseases or any other types of diseases. If farmers fail to identify a disease that on rice crop leaves, then it results in crop failure, it is one of the challenges that farmers confront, and as a result, it has an impact on rice production and makes delivering high-quality and quantity food to the population extremely difficult. It certainly increases the economic crisis in the agricultural field, and increase in price of rice crop. Most of farmers for their living expenses they rely upon agriculture and if it fails, they will face hard time, nowadays farmers commit suicide because of financial losses in agriculture. The manual identification definite disease is time consuming and not efficient, if definite disease is found, then farmers can take all sort of various disease control procedures in earlier stage, can also prevent from crop failure. For rice leaf disease detection, various methods and techniques are used. Bacterial leaf blight, Leaf smut, Hispa, and Brown spot diseased images are considered and segmented using Image processing technique, and important features are extracted from the segmented area using feature extraction method. These features will be used as inputs in neural network classification algorithms that are able to detect the exact disease.

**IndexTerms** – Rice leaf disease detection, Image processing, Feature extraction, Deep learning algorithms.

## Introduction

In India agriculture is the backbone, every year India produces various types of crops such as wheat, rice, pulses, cotton, peanuts, but demand for the rice is more, as it is one the most chief crop and not only the rice is consumed huge and the cultivation of rice crop is largest compare to the entire world. The disease is easily transmitted in the rice crop, and the spread of other plant diseases has accelerated in recent years, in India, an approximately 15-25 percent of crop production is lost due, weeds, pests and diseases. The variety of rice plant

disease such as fungal disease, bacterial disease, viruses, these are the disease which affects the crop such way that it restricts the growth of a crop, decrease the quality and quantity of crop and has capability to damage the any parts of crop both internally and externally. Leaf smut, Brown spot, Bacterial leaf blight, and Hispa are some of the most frequent diseases that affect rice leaves. These diseases can cause crop losses of up to 75%, and lakhs of hectares of rice are infected each year. Identifying the exact disease is challenging task for farmers, time consuming and each disease might look similar for our eyes, but they are not, these diseases differ from their own visual symptoms and it has its own texture and color. As a result, disease detection in various plant components is extremely important and useful, plays a vital role in crop life cycle, if the exact disease in not identified properly and on right time, then the disease can spread across entire crops, then on wards it hard to control and get rid of diseases not a easy task for farmers, it certainly leads to crop failure, it tend affects the availability of food in the market , and also impacts the economy of a country, especially if the country is agriculture-dependent and affects the farmer financially. Using distinct types of data set from websites namely Kaggle, UCI Machine repository, it contains common rice leaf disease in it. The different types of deep learning and machine techniques, some techniques are images processing technique play vital role to identify and analyze image for classification purpose, machine learning classification algorithms such as Support vector machines (SVM), Random Forest method, decision tree algorithm, K-Nearest Neighbor (KNN), AdaBoost, Neural Networks, and Transfer learning are all examples of machine learning algorithms. Out of all these the Images processing technique, Convolution neural network and Transfer learning model are best suit for this kind of problem. Creating and training our model with a greater number of both diseased and not diseased images, now the model is ready to detect exact disease that present and surface of rice leaf with more efficient and accurate way. Most of time farmers identify the disease in manual way is very time consuming, however, utilizing image processing, machine learning, and deep learning technologies, the disease can be detected automatically, where most of the burden will

# Forest Fire Susceptibility using Neural Network

Amaravathi M<sup>1</sup>, Chandan Kumar<sup>2</sup>, Likhitha N<sup>3</sup>, Nandini J K<sup>4</sup>, Kumar K<sup>5</sup>

Computer Science and Engineering<sup>1,2,3,4,5</sup>, K S Institute of Technology<sup>1,2,3,4,5</sup>

[amaravathil57@gmail.com](mailto:amaravathil57@gmail.com)<sup>1</sup>

[chandankumar6070@gmail.com](mailto:chandankumar6070@gmail.com)<sup>2</sup>

[likhitha.n2135@gmail.com](mailto:likhitha.n2135@gmail.com)<sup>3</sup>

[nandini.jk456@gmail.com](mailto:nandini.jk456@gmail.com)<sup>4</sup>

[kumark@ksit.edu.in](mailto:kumark@ksit.edu.in)<sup>5</sup>

**Abstract**— Forest fires have impacted negatively on ecosystems, cultures, and economies all across the world. Modeling and anticipating the incidence of wild fires are essential to minimize these damages and reducing forest fires because they can help with forest fire prevention strategies. The convolutional neural network (CNN) has emerged as a key state-of-the-art deep learning method in recent years, and its application has enriched a wide range of fields. As a result, we proposed a CNN-based spatial prediction model for forest fire susceptibility. The concept is that this model is used to identify a fire or the beginning of a fire in a forest using (aerial) surveillance data. In the event of a fire, the model might be applied in real time to low-framerate surveillance video or picture and provide a warning. The network will be trained on a dataset that includes images in three categories: 'fire,' 'no fire,' and 'smoke'. The majority of the photographs will be of forests or forest-like situations. Photos labelled 'fire' have visible flames, while images labelled 'smoke' have smoke sensing the smoke. Finally, photographs with the title 'no fire' were taken in forests. We will leverage the data augmentation function offered by Keras (Python Deep Learning API) to conduct a series of random transformations on photos before feeding them to the network in order to train a network that generalizes well to new images. Finally, our goal is to create a legible project which handles every aspect of CNN creation and training. Early detection of fire in the forest is very helpful and our biodiversity can be saved.

**Keywords**— Introduction, Literature Survey, Methodology including CNN architecture, Conclusion and References.

## I. INTRODUCTION

A forest fire is a phenomenon that can be defined as an accidental fire in a flammable vegetation region. They have the potential to cause plenty of environmental disasters, as well as significant economic and ecological damages. Forest fire surveillance and tracking have become an important method for preventing this, attracting increasing interest throughout the world. Massive forest fires occurred in a number of locations across India's Karnataka state's Bandipur National Park in February 2019. The Indian Space Research Organization's (ISRO) National Remote Sensing Centre conducted an estimate of the total area damaged by the fire. On February 25, 2019, was projected that the burned area had grown to around 10,920 acres in the five days since February 21, 2019. Because regional forest fire susceptibility is typically influenced by a variety of factors and has typical nonlinear and complex properties,

developing accurate forest fire prediction models remains a challenge. For predicting forest fire susceptibility, a variety of methodologies have been proposed, ranging from physics-based methodologies to statistical and machine learning (ML) techniques. ML algorithms have demonstrated the capacity to deliver superior results for the geographical forecast of wildfires when compared to standard qualitative and statistical analytic methodologies. Artificial neural networks, random forests (RF), support vector machine (SVM), multilayer perceptron neural network (MLP), kernel logistic regression (KLR), naive Bayes, and gradient descent trees are just a few of the machine learning algorithms that have already been successfully developed and commonly used to create wildfire susceptibility visualizations.

Deep learning (DL) techniques have lately gotten a lot of attention and have had a lot of success. Deep learning techniques are widely used in domains such as object identification and detection, audio recognition, and natural language processing because they aim to uncover numerous representation levels. In recent studies in areas such as disaster damage detection, remotely sensed image classification, and landslide susceptibility mapping, the convolutional neural network (CNN) has been recognized as one of the most effective and commonly used DL algorithms, which has generated major improvements.

The CNN can fully utilize contextual information and identify several layers of representations from input data, making it better suited to the evolution of fire event spatial features. The DL method shows deep characteristics and may differentiate between geographical entities. As a result, examining the use of the CNN algorithm in forest fire susceptibility assessments has some practical value. The likelihood assessment of fire occurrence in a region is characterized as forest fire susceptibility in this article. The major goal of this research is to use contextual-based CNNs with deep architectures to forecast regional forest fire susceptibility spatially. The forest fire susceptibility model is built using a CNN, and the model's hyperparameters were tuned to increase predictive accuracy.

## II. LITERATURE SURVEY

# HUMAN DERMIS CANCER DETECTION

Mr. Raghavendrachar .S<sup>1</sup>, Akshay B R<sup>2</sup>, Karthik P H<sup>3</sup>, Sahana V<sup>4</sup>, Y Mrudula Jain<sup>5</sup>

<sup>1</sup>Assistant Professor, <sup>2,3,4,5</sup>Under Graduate Student

Dept of Computer Science and Engineering, K S Institute of Technology,  
Bengaluru, Karnataka.

**ABSTRACT:** The prevalence of both non-melanoma and melanoma skin cancers has been increasing over the past decades. Skin cancer diagnosis can be a cathartic experience, however a physician can face with many trials and tribulations. The personal burden of skin cancer can be significant, if detected at an early stage, 5-year survival rates are over 90%. Image processing has always the potential to improve the diagnostic accuracy. Recent research in dermatology exemplify that image processing using ML for selected lesions is similar or of higherranking when compared to human experts in image based diagnosis under experimental conditions. This paper defines the best approach to identify/diagnose the cancer at an early stage by distinguishing the Benign from Melanoma skin cancer with CNN algorithm. The performance of this method is experimented on 2000 training samples. Accuracy for this method was encouraged and can reach up to 87%

**Keywords:** CNN(Convolution Neural Networks), Deep learning, SVM(Support Vector Machine), KNN(K-Nearest Neighbor), ABCD(Asymmetry, Border, Color, Diameter), SVM(Support Vector Machine), Dermoscopic, Pre-processing, Feature Extraction, Segmentation.

## INTRODUCTION

This project aims at detecting the cancer and the type of cancer at an early stage. Approximately one in five people develop skin cancer in their lifetime, almost all skin cancer can be cured if found and treated early, there are two major types of skin cancer namely, Melanoma and Benign. Melanoma is the most serious type of skin cancer which develops in the cell and which produce melanin a pigment that gives a color to the skin. Research suggests that melanoma is increasing in the people who are under 40, especially women and can be treated successfully if treated at an early stage. This type of cancer can occur anywhere in the body. It is seen that they mostly develop in the areas that has or had exposure to the sunlight that includes face,

back, legs and arms. However, this does not mean that they don't occur in the areas that don't receive much sun exposure, such as soles of the feet, palms of the hand and fingernail beds. These hidden melanomas are more common in the people with darker skin. Benign refers to a condition or a growth which is not cancerous. This simply means that benign does not spread to other parts of the body. A condition is called as benign to suggest that it is not dangerous or serious. In many cases, benign tumors need almost no treatment. Doctors may simply wait and watch to make sure that they don't cause any serious problems. But a patient needs to undergo a treatment if there are any symptoms or cause any problems. The goal here is to remove the tumor without damaging the surrounding tissues. There are many numerous types of benign tumors and the exact cause of benign is often unknown. In many cases the patients are required to be monitored carefully, sometimes non-cancerous moles can turn into cancer at a later time if not monitored properly.

## LITERATURE SURVEY

1. **A novel approach on dermis cancer detection using image processing:** The detection of melanocytes in the epidermal area is an important stage in the diagnosis of skin melanoma using pictures. However, detecting melanocytes in the epidermis is difficult due to the presence of additional keratinocytes that look quite similar to melanocytes. This is a poll. Proposes a new computer-aided technique for segmenting melanocytes in histological pictures of the skin. For the initial segmentation of the image, a mean-shift algorithm is used to decrease the local intensity variation. Based on the domain prior knowledge, a local region recursive segmentation approach is developed to filter out the possible nucleus regions. A new descriptor called local double ellipse descriptor (LDED) was developed to identify melanocytes from other keratinocytes in the epidermis area. Following that, a domain prior knowledgebased local region recursive segmentation approach is presented to filter

# WEARABLE SAFETY DEVICE FOR CHILDREN

Mr. Raghavendrachar S  
Dept of Computer Science  
Assistant Professor  
K S Institute of Technology  
Bengaluru, Karnataka  
[raghavendrachars@ksit.edu.in](mailto:raghavendrachars@ksit.edu.in)

Sunaina Nayak  
Dept of Computer Science  
K S Institute of Technology  
Bengaluru, Karnataka  
[nayaksunaina88@gmail.com](mailto:nayaksunaina88@gmail.com)

Ruba Abdul Rahman  
Dept of Computer Science  
K S Institute of Technology  
Bengaluru, Karnataka  
[rubaabdulrahman456@gmail.com](mailto:rubaabdulrahman456@gmail.com)

Vishnupriya D  
Dept of Computer Science  
K S Institute of Technology  
Bengaluru, Karnataka  
[dvishnupriya1112@gmail.com](mailto:dvishnupriya1112@gmail.com)

Krithika K N  
Dept of Computer Science  
K S Institute of Technology  
Bengaluru, Karnataka  
[krithikanagaraj0@gmail.com](mailto:krithikanagaraj0@gmail.com)

**Abstract:** Attacks on children have been on the rise at an unprecedented rate in recent years, with victims finding themselves in perilous situations with little chances of contacting their families. The main goal of this project is to create a smart wearable device for children that uses advanced technology to ensure their safety. As a result, this strategy is perceived as sending an SMS from the children's wearable to their parents or guardians. This project employs cutting-edge technology to protect the youngster through the use of a GSM module, ensuring that the child does not feel abandoned while dealing with such social issues. An Arduino Nano, GSM, GPS, temperature sensor, heartbeat sensor, and a panic button will be included in the wearable. The heartbeat sensor detects the child's heart rate and delivers it to the guardian on a regular basis. If the child falls suddenly, the accelerometer detects it and alerts the parents. As a result, the parent has a sense of security.

**Keywords:** Wearable, IOT, Arduino Nano, GSM, GPS.

## I. INTRODUCTION

Cruel crimes against children have been on the rise in recent years, with victims finding

themselves in incredibly perilous situations where using their cellphones to notify their parents or the police is nearly impossible. Despite the fact that technology is constantly evolving, these acts continue to occur in numerous areas.

The major goal of this project is to use modern technology to create a gadget that provides "Smart Child Safety" to protect children, which will be far more effective than current methods in assisting victims.

The device has IoT monitoring and a GSM module that allows the child to be monitored at all times. It also has numerous sensors that are connected to a CPU and are used to detect exact signals such as heart rate, temperature, and other dangers and alert the parents.

In the event of a power outage, the wearable serves as a backup. On the device, there is an additional panic button. The purpose of this button is to notify parents and the police of a child's current location whenever they are in a perilous scenario. A GPS module is utilised to access their present location, and a GSM module assists in transmitting the information via SMS to designated contacts. In this approach, the device tries to provide child safety while remaining unobtrusive.

# A NEW IoT GATEWAY FOR SMART AGRICULTURE

Mr. Raghavendrachar S<sup>[1]</sup>, Poojashree K<sup>[2]</sup>, Preethi K<sup>[3]</sup>, Rekha N.C<sup>[4]</sup>, Shalini S<sup>[5]</sup>

<sup>1</sup>Assistant Professor, <sup>2,3,4,5</sup> Under Graduate Student

Dept of Computer Science and Engineering,

K. S. Institute of Technology,

Bengaluru, Karnataka

**Abstract:-** Agriculture is the backbone of Indian economy, it offers a range of domestic products to provide food security. Farming plays an important part in the development of country it is the significant part of Indian economy. The project's goal is to use current technologies and the Internet of Things (IoT) to transform traditional agriculture methods into smart agriculture. The robotic vehicle, which is a powerful agricultural machine with a big soil-clearing capability, is the system's most important component. This multipurpose system offers a new approach for tilling, farm levelling, seed planting, and harvesting with the least amount of manpower and labour, making it a cost-effective vehicle that also scares animals that enter into the field. Second, this project contains warehouse security features like temperature control, warehouse theft detection, storeroom humidity management, and a soil moisture detector. Also, the condition of the form is updated to user through blynk application, and also through this blynk application robot can be controlled.

**Keywords:** Raspberry pi, Farming, IoT

## 1. INTRODUCTION

Agriculture is very important to human life. It provides a means of subsistence for a sizable portion of the world's population. Many farmers still follow traditional farming approaches, which results in low yields. So, on using IoT one get more yield in less time by using IoT. This project

includes warehouse management system where in by using different sensors and other electrical components one can control the environment of warehouse and soil moisture condition. Robot is the major part of this project which can perform all agriculture related operations and it also scares the animals that enter into the field. It is important to update agriculture activities using the emerging technologies. The agricultural industry conducts a variety of studies. Many proposals call for the creation of a wireless sensor network that can monitor atmospheric conditions and offer information on many aspects of the atmosphere. However, researching atmospheric characteristics alone will not increase agricultural production, there are a variety of other factors that could reduce crop yield. The idea is to use automation, automation increases the production by reducing labour costs and increasing work speed in the field. By using robots, farming activities can be done quickly and sensors are used to safely store growing products. This project seeks to use IoT to change agriculture into smart agriculture.

On using advanced technologies for monitoring, managing can going to change the agriculture business so thanks to Internet of Things (IoT) applications. In the agricultural industry, technology is crucial for reducing labour costs and increasing crop productivity. Some of the activities are geared on supporting agriculturists in extending their businesses by providing a technology-based framework. The Internet of Things (IoT) uses cable LAN to connect

# Movie Recommendation System Using Machine Learning

Prof. Krishna Gudi<sup>1</sup>, Aruna P<sup>2</sup>, Monica S<sup>3</sup>, Dhruv Jyoti Shukla<sup>4</sup>, Dhanalakshmi B<sup>5</sup>

<sup>1-5</sup>Department of Computer Science and Engineering,

Visvesvaraya Technological University (VTU)

[krishnagudi@ksit.edu.in](mailto:krishnagudi@ksit.edu.in)

K. S INSTITUTE OF TECHNOLOGY

Bangalore, Karnataka - 560109

**Abstract**— In digital era, we have wide-range of resources such as items, music, books, movies and so on, finding the data based on user's interest becomes unerring, thus recommender systems will play a major role. A recommendation engine is all about suggesting a similar type of content or items by predicting user preferences. Eg: In case of OTT platforms the movies to watch, in the case of e-commerce sites the items to purchase will be suggested using recommender systems. This can be done by using Machine learning (ML) algorithms such as Content-based filtering (CBF), Collaborative filtering (CF), and hybrid filtering approach (HF). CF is classified into model-based approach and memory based approach. HF is a technique which is a combination of both content based and model based CF approach. XG Boost is used for improving the performance of recommendation engine.

**Keywords**— Machine learning (ML), user choice's, Hybrid Filtering (HF), Collaborating filtering (CF), Recommendation, Content-Based Filtering (CBF)

## I. INTRODUCTION

Recommender Systems are powerful filtering methods/techniques in the field of business. Google, Aha, YouTube, Netflix are all large business organizations that will use effective Recommender engines in order to grow their business. So there are mostly three types of recommender systems exists. They are content based approach (CBF), collaborative-based filtering (CF), and hybrid filtering technique (HF).

Recommender Engine is one of the facilities given to user. Recommender engines are the most instantaneously identifiable ML technique in today's technology world. We notice many services or platforms which will recommend movies that are based on previous interaction of user with the platform. They attempt to get likeliness and inclinations by ratings given by users and to

find unknown movies or data that are not realized but will fascinate or attract user. Due to improvement in recommendation engines all users round-the-clock anticipate for good recommendations, this has generated a large significance in organizations for enhancing their recommender systems. However, the difficulty of the issue seems MORE compound than it looks. Each user has various inclinations, in addition every single user will have a different preference based upon number of factors, like time, mood of the person or depending upon the user's current work. Building a system like this is quite challenging..

## II. LITERATURE REVIEW

In 2019, Nirav Raval , Vijayshri Khedar has conducted a research on the recommendation System .Collaborative filtering (CF) is classified using various approaches like matrix factorization, recommendations based on users and items. By using algorithms such as K-nearest, SVD, Alternating Least Squares (ALS). Movie recommendation systems can be improved by using the Pytorch library, in which the model would be trained to find the latent factors.[1]

In 2019, Wang Juan, Lan Yue-Xin, Wu Chun-Ying, Survey of Recommendation based on Collaborative Filtering where it describes that ,Traditional approaches majorly consists of (CF) collaborative filtering, CBF Content based Filtering. The common CF techniques are neighbourhood based CF, Hidden/latent factor model based CF, and Graph based CF. KNN model and XGBoost model are combined to form a hybrid collaborative filtering recommendation.[2]

In 2020, M.Chenna Keshava, S.Srinivasulu, P.Narendra Reddy, B.Dinesh Naik, Machine Learning Model for Movie Recommendation

# LitWit – LEARNING WITH UNDERSTANDING

Prof. Krishna Gudi<sup>1</sup>, Anushruti Singh<sup>2</sup>, Bhuvana Chandrika.G<sup>3</sup>, Kandimalla Krishna Pavithra<sup>4</sup>, Kovvuru Vinuthna Vani<sup>5</sup>

<sup>1-5</sup> Department of Computer Science and Engineering,

Visvesvaraya Technological University (VTU)

[krishnagudi@ksit.edu.in](mailto:krishnagudi@ksit.edu.in)

K. S INSTITUTE OF TECHNOLOGY

Bangalore, Karnataka - 560109

**Abstract**— A growing number of institutions have set up resources on their Web portal as a way to provide users (i.e. Students and Faculties) with information about their services and features. Generally, in colleges things are done manually such as notes, etc. This often students find it difficult to access information that they need for managing their learning requirements. They need to have a single portal that caters to all their learning needs which will help them with the following features time-saving, easy access and user friendly, etc. LitWit Portal aims to design web portal-based solutions for institutes where all the facilities will be provided online for various things like E-Learning, E-Notes, E-Resources, etc. This portal helps the students to give ideas about how to build a good resume with the help of the resume maker. It guides the students in their interview preparation. Through the interview experiences of the experienced one those who already faced it themselves. This particular portal helps the students understand their doubts much faster. They can chat with the same peer age group or with an expert faculty either by dropping a message in the comment box or chatting with that particular peer or faculty. This reduces the time for a student to get a clear idea about the solutions.

**Keywords**— E-notes, E-learning, Online Learning, Portal, Student

## I. INTRODUCTION

Education plays a vital role in student life, as it results in success. Sometimes students find it very difficult to get accurate solutions for their doubts while studying, as at times there are many resources that are available online. It becomes very difficult and time-consuming to understand which ones suit their needs.

Students would find it almost impossible to wait till the next day to clarify their doubts with their teachers. And even the teacher would also not want the students to waste their time.

Today's education scenario is rapidly changing due to the advancement of technology. With the

help of technology, this can be achieved by creating a web portal as portals are increasingly popular nowadays, enabling development and maintenance is very easy. We are designing a web portal LitWit, which will provide students with E-NOTES, E-RESOURCES, E-LEARNING, etc.

This particular portal helps the students understand their doubts much faster. They can chat with the same peer age group or with an expert faculty either by dropping a message in the comment box or chatting with that particular peer or faculty. This reduces the time for a student to get a clear idea about the solutions.

This portal also helps the students to give ideas about how to build a good resume with the help of the resume maker. It guides the students in their interview preparation. Through the interview experiences of the experienced one those who already faced it themselves. It gives the students option to download the notes which are available on the home screen. These notes can be uploaded by any user. They can also rate the notes, based on the rating students will understand which notes are best to study instead of wasting time.

## II. LITERATURE REVIEW

In 2020, MILTON CAMPOVERDE-MOLINA, SERGIO LUJÁN-MORA, AND LLORENÇ VALVERDE GARCÍA [1] carried out a conceptual-based literature review on "Empirical studies" concentrating more on web accessibility this gives the meaning – that websites, tools & technologies are designed and developed so that people with the disorder can use them. This work presents a methodological guide that defines guidelines for the development of accessible virtual learning environments, considering. The four dimensions of this diagnosis are accessibility conditions of the different components of the environment, from which it is proposed to plan the actions that each component must carry out in the later implementation stages of the Web. The aim of this systematic literature review is to analyze the empirical methods of evaluating accessibility to educational



# SUSPECT IDENTIFICATION ALERT SYSTEM

Mr.Krishna Gudi<sup>1</sup>, Prerana DS<sup>2</sup>, Anuhya Kulkarni<sup>3</sup>, Madhusudan G<sup>4</sup>, Pavithra KR<sup>5</sup>

<sup>1</sup>Assistant Professor, <sup>2,3,4,5</sup> Undergraduate Student

Dept of Computer Science and Engineering,  
K S Institute of Technology,  
Bengaluru, Karnataka.

**Abstract**— Identifying a suspect in a crowded place like an airport, mall or even a small, significant, and crowded place can prove to be a tedious job if automation is not devised. The following project aims to identify a suspect specifically without having to make assumptions and creating any unnecessary panic. We implement the machine learning algorithms and neural networks to train and identify a suspect from thousands of daily visitors.

**Keywords**— Augmentation, Haar Cascade, Convolutional Neural Networks, Machine Learning and recognition.

## I. INTRODUCTION

Face identification is a critical component of current security systems, but because machine learning algorithms require a huge dataset to achieve high accuracy, our approach provides an easy way to identify the suspect. The solution includes code for accurate face prediction utilizing data augmentation techniques. This research develops a new strategy combining convolutional neural network (CNN) with the augmented dataset to address the problem of human face recognition on tiny original datasets. Through multiple modifications of the facial photos, the initial tiny dataset is enhanced to become a huge dataset. Using the clever CNN, the features of the faces can be efficiently retrieved based on the enhanced face picture dataset, and greater face recognition accuracy can be attained. Several trials and comparisons with commonly used facial recognition systems demonstrate the usefulness and superiority of the suggested strategy. Haar cascade is an object detection technique or a model that is used to determine the position of faces to train a face recognition system. It is based on edge detection, which means that it uses the lines/edges in the face and treats areas with amplified pixels as a feature. The Haar feature is then navigated to the next block after calculating the Haar value.

## II. LITERATURE SURVEY

In this section we will go through all the science papers that have helped us gain a perspective towards our project.

[1] a new method that integrates neural networks with augmented dataset is devised and is

compared with some of the previously existing methods. The paper attempts to devise a method for face recognition using small datasets by making several transformations.

[3] the area of face recognition is ventured in real time instead of data fed from online pre-collected data, this is enabled by modern high-resolution processor and cameras [7] The human face detection algorithm makes up for the drawbacks of the primitive Viola-Jones' cascade classifier and increases the chances of the face recognition.

[11] The result of this paper shows the liability and productiveness in better face recognition performance. CLAHE (Contrast Limited Adaptive Histogram Equalization) is a recent and updated AHE that is used in preprocessing techniques. The 2nd step is Orientation binning in extracting the HOG characteristics. HOG stands for Histogram of Oriented Gradients. (Support vector machine) SVM is performed to classify images.

[8] The paper clarifies the CNN model by creating layers of convolutional and sampling layers one after the other. LeNet5, AlexNet, ZF Net, GooLeNet, and VGGNet architecture are analysed in-detail.

TABLE I

| TITLE OF THE PAPER                   | AUTHOR                               | YEAR OF PUBLICATION | TECHNIQUE/CONCEPT      | METHOD                            | RESULT            |
|--------------------------------------|--------------------------------------|---------------------|------------------------|-----------------------------------|-------------------|
| Face recognition using deep learning | Li, Siyuan, et al.                   | 2015                | Deep learning          | Convolutional neural network      | High accuracy     |
| Face recognition using Haar cascade  | Viola, Paul S., and Michael J. Jones | 2001                | Haar cascade           | Edge detection                    | Fast and accurate |
| Face recognition using SVM           | Viola, Paul S., and Michael J. Jones | 2001                | Support vector machine | Linear classifier                 | High accuracy     |
| Face recognition using AlexNet       | Krizhevsky, Alex, et al.             | 2012                | AlexNet                | Deep convolutional neural network | High accuracy     |
| Face recognition using VGGNet        | Simonyan, Karen, et al.              | 2014                | VGGNet                 | Deep convolutional neural network | High accuracy     |

TABLE II

# Personal Assistant for Visually Impaired

Prashanth H S<sup>1</sup>, R. Dekshitha<sup>2</sup>, Yogita Raikar<sup>3</sup>, Swetha Bijanapalli<sup>4</sup>, T. Hemanth Chowdary<sup>5</sup>

<sup>1-5</sup>Department of Computer Science and Engineering, K. S Institute of Technology  
Bengaluru-560109, India

<sup>1</sup>[prashanthhs@ksit.edu.in](mailto:prashanthhs@ksit.edu.in)

<sup>2</sup>[dekshi17@gmail.com](mailto:dekshi17@gmail.com)

<sup>3</sup>[yogitaramesh11@gmail.com](mailto:yogitaramesh11@gmail.com)

<sup>4</sup>[swethabijanapalli@gmail.com](mailto:swethabijanapalli@gmail.com)

<sup>5</sup>[hemanthchowdary743@gmail.com](mailto:hemanthchowdary743@gmail.com)

**Abstract**— Many people around the world suffer from vision impairment caused by birth or accident. External gadgets or humans must provide constant assistance. However, not everyone can afford the equipment, and humans cannot always be relied upon. As a result, a mobile application that will operate as their constant companion is being developed to provide a solution. In today's automated environment, mobile phones are widely used. There are many applications available, but only a few are particularly intended for non-sighted persons. The major goal of this project is to create a highly accessible interface that can execute a variety of functions and communicate with the user via voice commands and rudimentary screen touch. Users can basically read with their ears. In essence, users can read with their ears and type with their voices. Machine learning and voice recognition are the major components. This application provides assistance to recognize the nearby objects by using the tensorflow model. Texts can be read out to the user, when the image is captured by the mobile camera. Furthermore, QR codes can be scanned for product identification and the entire bill is generated. They can also perform calculations through commands. Phone calls and messages can be sent without any hassle. Users can also be notified about current date and time, location, weather of any city and alerted about their battery status.

**Keywords**— Visually impaired assistance, Voice assistant, Android application, Object detection, Tensorflow, QR code scanner, Text recognition, Speech recognition, Text-to-speech

## I. INTRODUCTION

The advancement in the field of Artificial intelligence has resulted in the existence of numerous virtual assistants. Besides such progression, visually impaired communities still get very few opportunities or platforms that are receptive and convenient. The proposed mobile application aids them with tasks that are not straight-forward to them but may appear simple to normal sighted people. It communicates with the end-users, receives their voice command and performs specific activities for them. Commands are simple English words that can be easily learnt or used by most people irrespective

of language or age or background. Google text-to-speech API is used for the purpose of recognizing the provided commands. The main features of the application comprises object detection and recognition, text recognition, qr code scanner, calculator, detect current location, date and time, battery level, current weather, make calls and send messages. The system consists of a camera that acquires images of objects/texts/QR code and sends it to the application, where a powerful processor derives information from it and responds to the user through a distinct audible voice output. Overall, it enables the visually impaired to perform several tasks with ease.

## II. LITERATURE SURVEY

In the field of science and technology, a number of efforts have been made to assist visually impaired persons. This section reviews and highlights a few of such research publications.

Kanchan Patil et. al. presented Guidance System for Visually Impaired people [1], which is a voice-over chat-bot to interact with the users through voice messages. Image captioning, object detection, face-emotion detection, face recognition and reading text are among the five modules that are implemented. Image processing is performed using OpenCv, while Tensorflow was utilised to recognize objects and caption them. Pyaudio and speech recognition tools are used to perceive the user's commands. To convert the text results to voice, gTTS and pyTTSX are used. Its inability to recognize commands in noisy situations is one of its drawbacks.

Abdul Majid Norkhalid et. al. proposed Mobile Assistance for Visually Impaired People-Speech Interface System [4]. The Android-based mobile application "Direct Me" was developed to assist the visually impaired community in navigating by combining a Speech Interface System with object recognition and distance. This speech-to-text mobile navigation application has four key components: Automatic Speech Recognition to detect voice, Natural Language Processing to interpret context, Route Processing Middleware to process route commands, and Map API to map the route.

# AUTONOMOUS CAR

Mr. Prashanth H S  
Assistant Professor  
Dept. of Computer Science  
K. S Institute of Technology  
Bengaluru, Karnataka  
[kushalkumarbn@ksit.edu.in](mailto:kushalkumarbn@ksit.edu.in)

Subramanya N  
B. E Student  
Dept. of Computer Science  
K. S Institute of Technology  
Bengaluru, Karnataka  
[subramanyagowda8123@gmail.com](mailto:subramanyagowda8123@gmail.com)

Suraj C Jawoor  
B. E Student  
Dept. of Computer Science  
K. S Institute of Technology  
Bengaluru, Karnataka  
[jawoorsuraj@gmail.com](mailto:jawoorsuraj@gmail.com)

Saurav S Makam  
B. E Student  
Dept. of Computer Science  
K. S Institute of Technology  
Bengaluru, Karnataka  
[sauravsmakam30@gmail.com](mailto:sauravsmakam30@gmail.com)

Rahul P  
B. E Student  
Dept. of Computer Science  
K. S Institute of Technology  
Bengaluru, Karnataka  
[rahulgowdaru1@gmail.com](mailto:rahulgowdaru1@gmail.com)

**Abstract**— These Self-driving cars are one of the most promising prospects for near term Artificial Intelligence research. The state-of-the-art of this research leverages large amounts of labelled and contextually rich data, which abounds in driving. From a complex perception and control perspective, the technology to correctly solve driving can potentially be extended to other interesting tasks such as action recognition from videos and planning. An approach for self-driving cars that is economically attractive while still expanding the AI frontier should be based on vision, which is also the main sensor used by a human driver.

Perhaps the most obvious challenge in a fully autonomous vehicle is that the whole point is for the driver to no longer be driving the vehicle. That means that, by definition, the driver can no longer be counted on to provide control inputs to the vehicle during operation. While significant challenges remain in safety-certifying the type of algorithms that provide high-level autonomy themselves, it seems within reach to instead architect the system and its accompanying design process to be able to employ existing software safety approaches. In this project, the prime objective is to code efficiently and the usage of the appropriate and efficient algorithm to simulate the car moments with better accuracy.

This paper introduces the autonomous robot which is a scaled down version of actual self-driving vehicle and designed with the help of neural network. The focus is on building autonomous robot and train it on a designed track with the help of neural network so that it can run autonomously without a controller or driver on that specific track. The robot will stream the video to laptop which will then take decisions and send the data to raspberry pi which will then control the robot using motor driver. This motor driver will move the robot in required directions. Neural Network is used to train for the traffic signs to detect the traffic signs and an algorithm for lane line detection. After training a model for the traffic sign a collective decision is taken from both lane line detection algorithm and the traffic sign model. This approach is better than conventional method which is done by extracting specific feature from images.

**Keywords**— Computer Vision using OpenCV, Convolutional Neural Networks with Keras, TensorFlow Lite, Raspberry-Pi, ESP32, LeNet Model, Perceptron-based Neural Network.

## I. INTRODUCTION

Consumers all around the whole world are enthusiastic about the advent of autonomous cars for the public. An autonomous car can operate without human control and does not require any human intervention. Campbell et al. stated that modern autonomous vehicles can sense their local

environment, classify different kinds of objects that they detect, can interpret sensory information to identify appropriate navigation paths whilst obeying transportation rules. Considerable advancements have been made in giving an appropriate response to unanticipated circumstances where either a backlash can occur in the vehicular systems or some medium in the external environment may not behave as predicted by internal prototypes. To carry out successful autonomous navigation in such situations, combining a variety of technologies from different disciplines that span computer science, mechanical engineering, electronics engineering, electrical engineering, and control engineering, etc. is significant.

The timeline of autonomous cars begins in 1926 with the world's first radio-controlled car- 'Linriccan Wonder'. Significant advances in autonomous car technology have been made after the advent of the vision guided Mercedes-Benz robotic Van in 1980, since when the main focus has been on vision-guided systems using LIDAR, radar, GPS, and computer vision. This developed into the autonomous technologies present in modern cars like adaptive cruise control, lane parking, steer assist, etc. And, in the future, we will be part of a future where fully autonomous cars will be a reality, based on official forecasts by various automobile companies.

Autonomous cars provide excellent benefits, but some challenges do exist. Although the notion has been rejected, it is believed that the advent of autonomous cars would lead to a decrease in driving-related jobs. Also, situations like the inability of drivers to regain control of their cars due to the inexperience of drivers etc. is an important challenge. Lots of people love driving, and it would be difficult for them to forfeit control of their cars. Autonomous cars also pose challenges in interacting with human-driven vehicles on the same route. Another challenge to autonomous cars is that who is to be held liable for damage- the car manufacturing company, the car's occupants/owner, or the government. Thus, the implementation of a legal framework and establishment of government regulations for autonomous vehicles is a major problem. Software reliability is also a major issue.

Also, there is a risk of a car's computer or communication system being potentially compromised. There is a risk of an increase in terrorist and criminal activities, for instance, cars could potentially be loaded with explosives by terrorist organizations and miscreants. They could also be used as

# IOT BASED SYSTEM FOR COVID-19 PREVENTION

**1 Mrs.Beena K, 2 Ranjitha HD, 3 Sushmita BK, 4 Ramya R, 5 Bhavyashree R.**  
**1 Assistant professor, 2,3,4,5Undergraduates,**  
**Dept of Computer Science and Engineering, K S Institute of Technology, Raghuvanahalli,**  
**Bengaluru, Karnataka.**

**ABSTRACT:** Since the first report of coronavirus sickness (caused by a novel severe acute respiratory syndrome) in Wuhan in December 2019, it has become a public health issue in China and even around the world. On January 30, 2020, the World Health Organization designated the outbreak as a Public Health Emerging of International Concern. This pandemic is wreaking on societies. The significant number of cases raises concerns about the spread of the pandemic, which may lead to the idea of bringing it to prevent further infection. Taking extreme precautions, on the other hand, may be effective in preventing this pandemic. Thus, we put forwarded computer vision to monitor activity and detect violations as well sensors which trigger real time alerts .(The pretrained models such as the DNN, and YOLOv5), the Arduino Uno Board is used as a microcontroller.

**INDEX TERMS:** DNN, YOLOV5,DBSAN classifier and Arduino Uno board.

---

## I. INTRODUCTION

The End of 2019, "Coronavirus Disease" first found in Wuhan, and it rapid have emerge as a public health concern in China. This pandemic is taking a toll on societies and economies all around the world, culminating in a worldwide fitness disaster. [1] it's associates emerging, communicable disease caused by Severe Acute metastasis Syndrome Coronavirus a pair of (SARS-CoV-2) [2] everywhere the globe, particularly within the third wave, COVID-19 has been a major aid challenge [3] several shutdowns in several industries are caused by this pandemic. In addition, many sectors akin to infrastructure construction and maintenance comes haven't been suspended owed to their significant result on people's routine life. By now, the virus has apace unfolded to the bulk of the countries worldwide. [4] The statistics (26/03/2022) provided by the WHO show 480,333,071 confirmed cases, 6,144,279 deaths

and 414,641,868 Recovered. [5] per the centres for unwellness management and bar (CDC), coronavirus infection is transmitted preponderantly by metastasis droplets made once individuals breathe, talk, cough, or sneeze and painfully will increase aerosol emission when human speak and shout (loudly). [6] Therefore, to forestall speedy COVID-19 infection, several solutions, akin to confinement and lockdowns, are instructed by the bulk of the world's governments. [7] argued that as a result of strict stay-at-home will greatly impact people's means, the price of staying domestic can turn out to be outweighing the threat of contamination from going out. [8] In precis, COVID-19 dealing with could contain a gratitude of the numerous elements that calibrate payoffs in order that each person and governmental selections coin closer to safety. It is genuine Nevertheless, it created a route for

# Dilemma over IP over Avian Carrier with Quality of Service

Beena K<sup>1</sup> Aakriti<sup>2</sup> MahakShree<sup>3</sup> Aqsa Aqeel<sup>4</sup>

<sup>1</sup> Assistant Professor, <sup>2,3,4</sup> Under Graduates

Department of Computer Science and Engineering

K S Institute of Technology

Bengaluru, Karnataka

**Abstract:** This paper aims to point out faults with RFC 1149, "A Standard of Transmission of IP Datagrams on Avian Carriers" and RFC 6214[4], "Adaptation of RFC 1149 for IPv6" which aimed at integrating the experiments of RFC 1149 into IPv6. This should be treated as a review of the two and not advocated as a standard for IP protocols.

**Keywords:** IP protocols, datagrams, Avian Carriers

## INTRODUCTION

The implementation of RFC 1149 poses a threat to the security of data transmission. Since it was based on IPv4, it does not work well with IPv6. These problems are addressed in IPv6 but the security threats remain imminent.[1]

## WORKING

According to RFC 1149[2], the avian carriers are categorized by establishing bar codes imprinted on the bodies of the carriers. When a carrier passes a checkpoint, the bar code is scanned. Depending on the service level of the incoming carrier, they are sent in the queue with their respective services and are prevented from exiting before the scheduled time.

The deletion of packets can be executed by painting the carriers with red paint while they are in the queue.

Bulk retrieval of data will be done using the powerful Get-Net operator. As the formation of the carrier is done in the large V shape.

## DISADVANTAGES

We can provide a secure network for the carriers through prime or choice class, wherein prime class acts as a self-keying for public-key

encryption. Some of the distributors falsely classify choice carriers as prime carriers.

If there are mirrors present in the lane between the source and destination point then there are high chances of the carrier getting confused. Mirrors create an illusion of depth and reflect the background which causes confusion among the birds and results in them flying into it.

Round robin queuing is not preferred as it doesn't entail an auto-homing feature. From the bird's point of view after the bird is enqueued then if this round-robin scheduling is followed then the exact location of the bird in the queue will not be known.

For appropriately defining the species of avian carriers who will be perfectly equipped to act as carriers, a trial of sorts must be held wherein the participants would be tested on efficiency and accuracy. This test would be expensive and time-consuming and would still not ensure the accuracy of data transfer.

NAT is also not preferred as modifying the carriers with brain-embedded chips is not efficient, plus the avian carriers may accidentally swallow it.

Decapsulation of data packets may be compromised as the order in which data packets are received might get disrupted. The decapsulation entails removing header and trailer info to move as the total time to live (TTL) of the carrier service is of 15 years, The time expanded in their training and costs might have to be exerted again. This might not serve as the most efficient technique.

Carriers if based on the tree that is being pruned have a high chance of being lost. If the tree is part of the router network, then it being pruned

# E-HIRE

Mrs. Beena K <sup>1</sup>, Shivangi Srivastava <sup>2</sup>, Shubhashini R <sup>3</sup>, Vijayashree N R <sup>4</sup>

<sup>1</sup>Assistant Professor, <sup>2,3,4</sup>Under Graduate Student

Dept of Computer Science and Engineering

K S Institute of Technology

Bengaluru, Karnataka

**Abstract** - Salesforce is the world's #1 customer relationship management (CRM) platform. It helps in marketing, sales, commerce, service and IT teams work as one from anywhere- so you can keep your customers happy. The main purpose of Einstein bot is to interact with customers quickly and accurately without waiting for a human agent. Einstein bots can send messages, ask questions and perform the actions based on the rules defined or based on the customer input. Einstein Agent chatbots, built natively on the Salesforce Platform, will allow any company to deliver automatic service at scale using Einstein AI technology.

**Key Words:** NLP (Natural Language processing), NLU (Natural Language Understanding)

## I. INTRODUCTION

Salesforce is the Customer Relationship Management (CRM) with a cloud-based platform. It also provides applications based on customer service, marketing, analytics, and application development. The main service is the cloud-computing. Artificial Intelligence (AI) has integrated in our daily lives with creation of intelligent software/hardware, which we call as agents. These agents can do a variety of tasks ranging from labor work to difficult operations which normal humans can't possibly achieve. A chatbot can be considered as a typical example of an AI system. It can also be called as smart bots, digital assistants, interactive agents. Mainly, a chatbot is a computer program that initiates a conversation between the human and the agent through voice commands or text chats. This project aims to build a new technology that help people create better jobs and communities. Salesforce Einstein bots are NLU based technology which trains chatbot to create a learning model which helps for interactions in chat window. The chatbots are now popular because there are many advantages of chatbots for users and developers. Since there is a greater accessibility to this technology, so the chatbots are available on mobile devices. Salesforce communities are brand spaces that work to facilitate

collaboration and connection for employees, business partners, and customers. Einstein is an NLU technology that trains chatbots to create a learning model. The learning model helps chatbots created with Salesforce understand customer interactions in a chat window. It's the learning that leads to one of the major benefits of chatbots: automation. There is an increasing demand for professionals from this field. Einstein Bots is available in Salesforce classic and Chatbots can handle simple customer concerns so agents have more time for hard cases. These chatbots are powered by AI to answer common customer questions. They help customers resolve simple questions and concerns quickly and free up agents for complex, human interaction.

## II. LITERATURE SURVEY

Akash Balachandar, Anusha D Kulkarni, [1] "Recruitment Chatbots", vol 5, Issue: 08, Aug 2018. Recruitment Chatbots mainly focusses on how chatbot behaves as human conversational partner using Goal oriented and general conversational dialogue system. This ensures Time and energy consumption. It also ensures the usage of bot characteristics in order to build it, train it and test it.

Sumit Wailthare, [2] "Artificial Intelligence based Chatbot" Issue: January 2019. Artificial Intelligence based Chatbot mainly focusses on executing web based chatbot using Pattern matching algorithm. It speeds up setting and in commencing the meeting. It also ensures high efficiency. It acts as effectual progressive tool for communication concentrating on conversational relations.

Tarun Lalwani, Shashank Bhalotia, Ashish Pal, Shreya Bisen, Vasundhara Rathod [3] "Implementation of chatbot system using AI and NLP", Issue: Volume VI, ISSN: 2347-5552, Volume-6, Issue-3, May 2018. Implementation of Chatbot is done using Artificial Intelligence and Natural Language Processing algorithms. It

# Depression Analysis using Machine Learning

Manoj Kumar S<sup>[1]</sup>, Srihari B Sondur<sup>[2]</sup>, Priyanka E<sup>[2]</sup>, Sanjay D Hebbar<sup>[2]</sup>

Assistant Professor<sup>[1]</sup>, Student<sup>[2]</sup>

<sup>[1][2]</sup> Department of Computer Science and Engineering,

<sup>[1][2]</sup> K. S Institute of Technology, Raghuvanahalli, Bengaluru, Karnataka.

**Abstract**— In this, we set forward a clever methodology for distinguishing the online media posts that are demonstrative of sorrow with the assistance of Long Short-Term Memory (LSTM) and Natural Language Processing (NLP) systems, Word implanting, tokenization, and factorization to recognize the message that communicates sensations of despondency and its connected opinions. The methodology precisely predicts feeling in the text through Deep Learning, which eliminates bogus up-sides by thinking about the prompt setting of words. The information for this examination has been scratched from public discussions on Reddit—a well know web-based media site. Naming is made prior to breaking down the information, which permits posts about a typical subject to be assembled. Posts from various gatherings examining melancholy and self-hurt are taken as the positive class, while posts from different, arbitrary gatherings are taken as the negative class. Given the variety of the negative class, the dataset might be supposed to be delegate of a true situation. The model created has applications across a wide range of spaces, for example, sent via web-based media and correspondence gatherings regularly visited by youngsters to identify conceivable hurtful inclinations.

**Keywords**— Natural Language Processing, Machine Learning, Python, Long Short Term-Memory.

## I. INTRODUCTION

With the arrival of social-media network as the most chosen platform for inter-person relationships such as content creation, content moderation, news, and even political mobilization has become very essential for social-media organizations. Content moderation is the method for identifying and escalating or removing the most probable or possible destructive or harmful content on social-media platforms, is a very important responsibility taken by the social-media companies or organization's these days. Through the globe, there are many legal, judicial and legislative cells which are now interrogating the mislead activities which can be considered as the hot yet

destructive topics in cybercrime and which is also the negative role of social-media in misleading news, illegal or anti-social activities, etc. One place or field where the content moderation is very essential at this point is to identify and flag social media uploads/tweets/comments/posts which depicts the symptoms of depression (psychological-illness) and self-harm. With the early detection and efficient flagging of such content can save from harm or injury and might be helpful. After the awareness of importance of mental health from the doctors, medical consultants, mental psychologist practitioner's, psychiatrists, celebrities. Depression is the most discussed, debated and essential at this hour. Depression and its symptoms vary from person to person, usually the depressive features are classified as anxiety, presence of sad emotion, feeling empty or alone, feeling left-out or ignored, irritable mood, insomnia or sleep disorder, restlessness, feeling negative for all the conversation, fear of being judged etc. As the day is getting advanced with the technology everything is getting digitalized and people throughout the globe tend to exchange or discuss about their feelings with the social media posts, tweets, uploads, comments, etc. And people feel secured and they won't be having the fear of being judged, this is because of the like-wise thoughts or likeminded users or people in the groups, or community.

## II. LITERATURE SURVEY

[1] A machine learning based Depression Analysis and suicidal ideation detection system using questionnaires twitter

The authors of the paper [1] describes about depression and their project as follows Depression is a disorder that has been a huge concern in our society and has been ceaselessly a hot topic for researchers in the world. Regardless of the massive amount of examination on understanding individual moods together with depression, anxiety, and stress supported activity logs gathered by unavoidable figuring gadgets like smartphones, foretelling depressed moods continues to be an open inquiry. In this paper, we have proposed a depression analysis and suicidal ideation detection system/framework, for predicting the self-destructive acts based on the level of depression. We assembled relentless data from understudies and

# Air Fare Prediction Using Machine Learning

Mr. Manoj Kumar S<sup>1</sup>, Brijesh S<sup>2</sup>, Nikhil M<sup>3</sup>, Narashima raju R<sup>4</sup>, Rayyaan Mohiaddin<sup>5</sup>

<sup>1</sup> Assistant Professor, <sup>2,3,4,5</sup> Student  
Dept of Computer Science and Engineering,  
K S Institute of Technology,  
Bengaluru, Karnataka.

**Abstract** — The cost of an airline ticket is influenced by a variety of factors, including travel distance, purchase time, fuel price, and so on. For pricing, each carrier has its own set of unique rules and algorithms. The inference of such rules and the modelling of price volatility are now possible because to recent advances in Artificial Intelligence (AI) and Machine Learning (ML). The Airline Origin and Destination Survey (DB1B) and the Air Carrier Statistics database are used in this study to suggest a unique application based on two public air transportation data sources. The proposed system uses machine learning algorithms to estimate the quarterly average ticket price based on multiple origin and destination combinations, referred to as the market segment, by combining the two databases as well as macroeconomic data.

**Keywords** — Price Prediction, Data Analysis, Random Forest Regressor, Testing, and Training are all index terms

## I. INTRODUCTION

Since the deregulation of the airline sector, airfare pricing techniques have grown into a complex framework of sophisticated rules and mathematical models that drive them. Despite the fact that these principles are still mostly understood, research has shown that they are impacted by a range of conditions. Traditional drivers of pricing strategy, such as distance, are no longer the sole determinants of price strategy. Economic, marketing, and sociological factors are all increasingly influencing flight pricing. Airline The price of a ticket for the same flight might vary considerably and significantly from one day to the next. Because the price of an aeroplane ticket fluctuates, it is incredibly difficult for a client to acquire one at the lowest feasible price. Customers may also utilise septimate analysis (reviews) to assist them decide which airlines to travel by looking at other people's experiences. The purpose of this study is to gain a better understanding of the elements that determine airfare and to create and fine-tune models that can anticipate airfare months ahead of time. The airlines' ultimate purpose is to generate a profit, while the client is looking for the best deal. Customers usually want to buy their tickets far ahead of time to prevent price hikes as the departure date approaches. In

fact, however, this is not the case. The consumer can save money by paying more for the same seat than they should.

## II. LITERATURE SURVEY

[1] Wohlfarth, proposed a ticket buying time enhancement model dependent on an extraordinary pre-preparing step known as macked point processors and information mining systems (arrangement and bunching) and measurable investigation strategy. This system is proposed to change over heterogeneous value arrangement information into added value arrangement direction that can be bolstered to unsupervised grouping calculation. The value direction is bunched into gathering dependent on comparative estimating conduct. Advancement model gauge the value change designs. A treebased order calculation used to choose the best coordinating group and afterward comparing the advancement model.

[2] Janssen, built up an expectation model utilizing the Linear Quantile Blended Regression strategy for SanFrancisco to NewYork course with existing every day airfares given by www.infare.com. The model utilized two highlights including the number of days left until the takeoff date and whether the flight date is at the end of the week or weekday. The model predicts airfare well for the days that are a long way from the takeoff date, anyway for a considerable length of time close the takeoff date, the expectation isnt compelling.

[3] Gini and Groves, took the Partial Least Square Regression(PLSR) for developing a model of predicting the best purchase time for flight tickets. The data was collected from major travel journey booking websites from 22 February 2011 to 23 June 2011. Additional data were also collected and are used to check the comparisons of the performances of the final model.

[4] Naive Bayes, (73.06% exactness, Softmax Regression (76.84% precision) and SVM (80.6% exactness) models in anticipating air ticket costs. Papadakis [5] anticipated that the cost of the ticket drop later on, by accepting the issue as a grouping issue with the assistance of Ripple Down Rule Learner (74.5 % exactness.), Logistic Regression with 69.9% precision and Linear SVM with the (69.4% exactness) Machine Learning models.



# Art Gallery With E-Commerce Using Web Development

Mrs. Geetha R <sup>1</sup>, Avinash Prasad <sup>2</sup>, Karthik K <sup>3</sup>, Kavita Chaudhary <sup>4</sup>, Shewani Chib<sup>5</sup>

<sup>1</sup> Assistant Professor, <sup>2,3,4,5</sup> Under Graduate Student  
Dept of Computer Science and Engineering,  
K S Institute of Technology,  
Bengaluru, Karnataka.

**Abstract** — An art gallery with e-commerce is a place where artists may display and sell their work. Local artists have suffered greatly as a result of the epidemic, since their skill did not reach a large number of people. As a result, people are leaving their professions to pursue secondary careers, resulting in the extinction of Indian traditional arts such as Manjusha Painting, Mysore Painting, Parsi Embroidery, Toda Embroidery, and others. This website allows local vendors and others to sell their goods over the internet from the comfort of their own homes. Users may either buy or add the artistic artwork to their cart from this page. The user may make an order by filling up some basic data like address, phone number, and payment methods, and the item in the shopping cart will be shown as an order. By signing in, registering, and utilizing it, the user can have access to a full web interface (if new). They may use their accounts to publish and sell their creative work. We provide SSL certificates to keep our website safe. By offering benefits such as purchasing, selling, and marketing their innovation, our suggested model will be shown to be acceptable for local sellers and others. This platform ensures that India's traditional and cultural arts do not perish, but rather contribute to elevate and preserve the country's ethnicity. Our mission is to ensure that art culture is conserved for future generations while also establishing legitimacy for artists who have worked hard to develop their skills.

**Keywords** — art, culture, e-commerce, selling, purchasing, searching, security, digital payment.

## I. INTRODUCTION

The intangible cultural legacy of India is well-known. Indian art includes a variety of disciplines such as painting, sculpture, ceramics, and textile art. Indian art has a long and illustrious history that precedes Indian civilization; it's no surprise that the achievements of Indian art make every Indian proud. This isn't the case at all. Only a few Indian artists have been regarded as having a stronghold on the art market or being able to sell their works for a greater price. The fact that it is primarily associated with Indian culture, as well as the manner of thinking about life and the complexity of nature, distinguishes it. This gives the country hope as it approaches a fork in the road. Indian art has been influenced by a wide range of civilizations.

Because India is a democratic country, every person who lives there is valued equally. So, when it comes to artists and their abilities, everyone has a distinct skill set that should be valued

equally. However, it is the case that only well-known artists get paid more, while local artists are underpaid. Local artists' circumstances have deteriorated since the outbreak. They are abandoning their professions and migrating to secondary companies because of the lesser pay, resulting in the destruction of our Indian art and culture. Our Paper is an online art gallery where artists may showcase their work as well as advertise and sell their works of art.

Some of the features of our project are as follows:

- Advancing traditional art forms.
- Purchasing and selling of works of art.
- A description of each Indian state's art and its origins.

## II. LITERATURE SURVEY

[1] Beatrix E.M. Hasbelsberger and Pawan V. Bhansing propose in their paper "Art Galleries in Transformation: Is COVID-19 Driving Digitization?"

With relation to how COVID-19 encourages art galleries to consider digital channels and their limitations, such as the absence of human distant connection, straightforward display of information online, online anonymity, confidence, emotional involvement, trust, and the lack of personal distanced interaction. These limitations have been found to be overcome by providing rich, informative videos, online talks, photos of the materials used in artwork, filmed guided tours, and online galleries should maintain a professional online presence with well-organized and structured content about each and every artistic concept.

[2] "E-commerce: The New Art Market," Archana Rani, Head & Associate Professor of Visual Art, R.G. College, Meerut,

Describe how the invasion of e-commerce has aided the resurgence of the Indian market and how it has impacted the Indian economy. The following are some of the outcomes: many young artists feel that selling art online is a fantastic alternative since it provides everyone a platform to demonstrate their ability and allows them to sell their original, ethical, and creative artworks to a broader audience. Because the art market is expanding and causing fierce rivalry among artists, various virtual art platforms, such as Fixdi, Artzolo, Eikowa, and others, have a large number of paintings and other artwork.

# Chrome Extension for Dropdown Code Editor

Mrs. Geetha R.<sup>1</sup>, Aritra Ray<sup>2</sup>, Saurav Suman<sup>3</sup>, Souvik Mandal<sup>4</sup>

<sup>1</sup>Assistant Professor,<sup>2,3,4</sup>Undergraduate Student  
Department of Computer Science and Engineering,  
K S Institute of Technology,  
Bengaluru, Karnataka  
<sup>4</sup>project.g4.25@gmail.com

**Abstract**— Since the IT boom, there has been a surge of software developers. There has been a lot of new projects conducted every day. But not everyone writes their code, we refer to online forums and various websites to get a remedy for our programming problems. We get multiple solutions but don't know which is the correct one or which works with our code better. We need to visit other online editors or download separate IDEs to check our code. In our paper, we have mentioned how we created a dropdown code editor which will help developers to check for outputs for a given code without opening an external IDE or website

**Keywords**— Extension, Skulpt, IDE, ManifestV3, Browser-based

## I. INTRODUCTION

Extensions are small bits of software that allow you to customize the look and feel of your browser. HTML, CSS, and JavaScript can be used to customize Chrome's functionality and behaviour. While any application or software can create timetables, to-do lists, and set notifications, Chrome extensions make it easy to keep organized while browsing the web. Due to COVID-19 spreading to various countries, it has affected many sectors, including education. New challenges arise in universities with study programs related to computer programming, which requires a lot of practice. Difficulties encountered when students should set up the environment needed to carry out programming practices. Also, they should install a text editor called Integrated Development Environment (IDE) to support it. Also these days people are reluctant to write their code, they usually refer to online forums or various websites to get a remedy for their programming problems and get numerous solutions. They may not know which code is correct or which works better with their program. They need to visit online editors or download external IDEs for verification. The problem with this is that external IDEs require space and sometimes come with ads. Also,

there is a risk of installing and exposing your device to malicious software. The same applies to online IDEs. To make this work easy, our idea is to develop a web extension for the Google Chrome browser that will provide users with appropriate services

## II. LITERATURE SURVEY

[1] On the development of a web extension for text authentication on Google Chrome

In this survey paper, the grammar words used were verified and verification of text authentication is also done by selecting samples from text and verifying it from the database using an extension after doing so, the extension will highlight the selected text and it will scan and check for the authenticity of the text sample, they created a web extension for the Google Chrome browser that allows users to check online texts by simply clicking on an extension button. When you click the button, the extension software's underlying algorithm pulls the texts from the currently shown web page. By comparing the obtained texts to a text database, the messages are verified and authenticated. Texts are highlighted in different colours, according to the comparison.

[2] Online Compiler as a Cloud Service

In this paper the problem addressed was that there is a need for several compilers to compile programs for different programming languages and instead of downloading different compilers for different programming languages, a programmer/user can refer online cloud-based compiler which can execute or compile different programming languages and it will also assign suitable compiler server automatically by detecting the programming language. The goal of this study is to solve the problem of compiler storage and portability. The user must submit the program into the user interface supplied without needing to install any compiler. Depending on the load on the backend compilers, the controller will decide which compiler server the program should be allocated to compile. The program will be compiled and run by the compiler server. After that, the output is returned to the user.

# BLOCKCHAIN BASED E-VOTING SYSTEM

Mrs Pallavi K N <sup>1</sup>, Praveen Kumar K <sup>2</sup>, P Sai Ram <sup>3</sup>, Rakshith Kumar N <sup>4</sup>, Pavan P <sup>5</sup>

<sup>1</sup>Assistant Professor, <sup>2,3,4,5</sup>Undergraduates  
Department Of Computer Science and Engineering,  
K S Institute of Technology,  
Bengaluru, Karnataka.

**Abstract** — Traditional electoral system has failed to maintain integrity, security and transparency of the voters and in present pandemic conditions, many voters are afraid to stand in long waiting queues to take advantage of their basic right (voting). So as to resolve this problem, we are using the blockchain technology and smart contracts for various regions and publish the written smart contracts on the opensource platform in order that anyone will verify the smart contract written by the election commission. This system solves the matter of transparency, security and integrity.

**Keywords:** Blockchain, Ethereum, Ganache, Truffle Suite, E-Voting, Decentralized voting.

## I. INTRODUCTION

Electronic voting or e-voting could be a basic component of democracy that permits the final public to own their say within the sort of a vote. It has numerous blessings over paper-based systems. Despite the benefits of e-voting, there are still challenges in achieving widespread adoption. One of these is guaranteeing that the systems are resilient against potential faults. The blockchain doesn't assign all knowledge to one server, however rather to a distributed info, which is a decentralized technique of allocating knowledge. The data is unfolded across all connected devices via peer-to-peer network of nodes that communicate with each other.

The blockchain is represented as a new, decentralized, and distributed technology that has the potential to boost a range of businesses. Expanding e-voting to incorporate blockchain technology can be the solution to addressing the current problems with the system. Bitcoin is said as the first-generation blockchain application. The Ethereum Foundation introduced smart contracts as a use case for second-generation blockchain.



Fig 1 : Voters standing in a queue



Fig 2 : Smart Contract

Smart contracts are items of code that are distributed across all blockchain nodes and solely run once a particular condition is met. The blockchain, in conjunction with smart contracts, appears to be a promising competitor for developing safer, cheaper, clear and easy to use electronic voting systems. An e-voting system must be safe, because it should not permit duplicate votes and should be completely transparent whereas to safeguarding the attendees' privacy.

# Diwali sales prediction using machine learning

Mrs. Pallavi K N<sup>1</sup>, Adarsh K<sup>2</sup>, Aniketh H<sup>3</sup>, Latha V<sup>4</sup>, M Sreelakshmi<sup>5</sup>

<sup>1</sup> Assistant Professor, <sup>2,3,4,5</sup> Student  
Dept of Computer Science and Engineering,  
K S Institute of Technology,  
Bengaluru, Karnataka.

**Abstract** — Understanding the purchasing behaviour of various consumers (dependent variable) in relation to various items utilising their demographic information (IS characteristics, the majority of which are self-explanatory). The most typical application in the domain retail business is machine learning. This approach aids in the development of a predictor with significant economic value for store owners, as it will aid in inventory management, financial planning, advertising, and marketing. Pre-processing, modelling, training testing, and evaluation are all steps in the model development process. As a result, frameworks will be created to automate some of this process and reduce its complexity. The algorithm we will use is Random Forest Regression, which is one of the most popular.

**Keywords** — Sales Prediction, Data Analysis is Random Forest Regression, Testing and Training.

## I. INTRODUCTION

"Diwali sales" are the greatest sales that take place during the Diwali festival, which falls in November. Accurate sales forecasting allows for effective industry management. To increase sales, a prediction model is created that hovers on the sort of product that sells the most. The behaviour of a consumer should be studied in order to forecast how much money he or she will spend on a sweet. We shall forecast the sales of a "retail sweet shop" on "Diwali sales" in this paper. We must study the independent factors in order to forecast the sales of different sweets. Diwali is one of the most popular celebrations in India, as it is observed by almost all communities. Because of the widespread custom of sharing presents and sweets, this is the best time for businesses to sell themselves. This is the time of year when household spending increases, with sweets accounting for a large percentage of it. Food is an integral aspect of each celebratory occasion, hence sweets account for a large amount of the gift market.

Two goals are highlighted in this study.

1. Analysing all customer data and determining correlations between independent factors and the goal variable.

2. Testing and training to predict projected sales.

## II. LITERATURE SURVEY

[1] Sumit Kalra, Boominathan, Perumal, Samar Yadav, and Swathi Jamjala Narayanan suggested a workflow for analysing and forecasting Black Friday transactions. The main goal is to analyse the data and anticipate what customers would buy based on different product IDs. Xgboost, Tfid transformer, Model1+ Model 2, and Extratreeregressor are the four methods employed. The four algorithms listed above outperformed in terms of accuracy and RMSE accuracy.

[2] Amruta Aher, Dr. K. Rajeswari, and Prof. Sushma Vispute suggested a methodology a workflow on Data Analysis and Price Prediction of Black Friday Sales using Machine Learning Techniques. The major goal was to estimate the sales that occurred on Back Friday. Ridge regression, Lasso regression, Decision Tree Regressor, and Random Forest Regressor are the methods used for prediction. 5-fold cross-validation was used to train the model. Mean Squared Error is the performance evaluation metric employed (MSE). With an MSE score of 3062.719, the Random Forest Regressor outperforms the other algorithms.

[3] A workflow on Machine Learning Application for Black Friday Sales Prediction Framework was proposed by Ramachandra H V, Balaraju G, Rajashekar A, and Harish Patil. The basic goal is to analyse all customer data and establish relationships between independent factors and the target variable in order to anticipate projected sales. Linear regression, Random Forest, Decision Tree, and Xgboost regression, as well as Random Forest Regression, are the methods used to make predictions. Root Mean Squared Error was predicted using five methods (RMSE). With an average accuracy of 83.6 percent and a minimal RMSE, the Random Forest regressor performed well.

[4] Purvika Bajaj, Renesa Ray, Shivani Shedge, Shravani Vidhate, and Prof. Dr. Nikhilkumar Shardoor

# Chronic Kidney Disease Prediction Using Machine Learning

Mrs. Rashmi H<sup>1</sup>, Narasimha Maiya G S<sup>2</sup>, Gagansuri M S<sup>3</sup>, Maharaj S<sup>4</sup>, Nikil B S<sup>5</sup>

<sup>1</sup> Assistant Professor, <sup>2,3,4,5</sup> Under Graduate Student  
Dept of Computer Science and Engineering,  
K S Institute of Technology,  
Bengaluru, Karnataka.

**Abstract** — Chronic Kidney Disease (CKD) is a condition which results in loss of kidney function gradually over a period of time. Chronic kidney disease develops when the kidneys become damaged and are unable to filter the blood properly. This damage may cause wastes to build up in the body. Because CKD patients are at a higher risk of End Stage Renal Disease (ESRD), It has become a significant public health issue. Dialysis has cost the nation's health-care system billions of dollars in recent years, and the costs are expected to rise further. Most middle and lower-income people in developing countries cannot afford expensive medical treatment. Chronic kidney disease has no signs in its early stages. The severity of kidney disease can be determined by the estimated glomerular filtration rate (GFR) and albumin levels. We will develop a system based on clinical data that will use a machine learning algorithm to predict the disease in its early stages.

**Keywords** — Chronic Kidney Disease, Support Vector Machine, Machine Learning, End-Stage Renal Disease (ESRD).

## I. INTRODUCTION

Chronic kidney disease (CKD), commonly known as chronic renal failure, is associated with a gradual loss of renal function. In other words, CKD is a disease that affects the proper functioning of the kidneys, meaning that the kidneys are not functioning as expected and blood cannot be filtered properly. The kidneys are a pair of reddish-brown bean-shaped organs, each kidney about 4-5 inches long. The kidney's job is to filter waste and excess water from the bloodstream and excrete it from the body through urine. All blood in our body flows through them about 40 times a day. Advanced chronic renal disease can cause the body to store harmful quantities of water, electrolytes, and waste materials. This disease is referred to as "chronic" since the kidney damage occurs progressively over time. As kidney disease advances, it can lead to kidney failure, which necessitates dialysis or kidney transplantation to maintain life.

Chronic kidney disease is identified as one of the world's most serious public health issues. CKD is the tenth biggest cause of death in the world. CKD affects 10% of the world's population. Lack of affordable treatment is killing millions of people each year. Bone disease, anemia, heart disease, high calcium, excessive potassium and fluid retention are all symptoms of kidney disease. Hypertension, High Blood Pressure, Diabetes, Family History and Old Age are considered to be the leading causes of CKD. As the numbers of CKD patients are increasing we require effective predictive measures for early detection of CKD that reduces renal failure and expensive treatment.

Machine learning techniques have recently been widely used for early sign and diagnosis of multiple diseases. Machine Learning (ML) plays an important role in diagnosing illness or disease simply by analyzing existing patient records and training models to predict new patient behavior. Machine learning (ML) is a subset of artificial intelligence in which computing machines learn automatically and thus prediction improves with training.

In a medical examination, 2 medical tests are conducted to determine chronic renal disease. That is, a urine test to look at albumin and a blood test to look at glomerular filtrate. The glomerular filtration rate (GFR) is a test that is used to find out how well our kidneys are performing. It is also the best test for measuring our level of kidney functionality and for determination of chronic kidney disease stages. There are 5 stages of damage severity based on GFR.

| Stage | Description                        | GFR<br>(mL/min/1.73 m <sup>2</sup> ) |
|-------|------------------------------------|--------------------------------------|
| 1     | Kidney damage with normal or ↑ GFR | ≥90                                  |
| 2     | Kidney damage with mild ↓ GFR      | 60–89                                |
| 3     | Moderate ↓ GFR                     | 30–59                                |
| 4     | Severe ↓ GFR                       | 15–29                                |
| 5     | Kidney failure                     | <15 (or dialysis)                    |

Fig. 1: Stages of Chronic Kidney Disease

## *Optical Heart Rate Detection via Webcam*

**Noor Sumaiya<sup>1</sup>, Rithana N Raj<sup>2</sup>,  
Zaina Khan<sup>3</sup>, Rashmi H<sup>4</sup>** *Computer  
Science and Engineering, Visvesvaraya  
Technological University, India* E-mail:  
[rithananraj@gmail.com](mailto:rithananraj@gmail.com)

<sup>2</sup>*Computer Science and Engineering, Visvesvaraya Technological  
University, India*  
E-mail: [nlight110@gmail.com](mailto:nlight110@gmail.com)

<sup>3</sup>*Computer Science and Engineering, Visvesvaraya Technological  
University, India*  
E-mail: [khanzaina307@gmail.com](mailto:khanzaina307@gmail.com)

<sup>4</sup>*Assistant Professor, Computer Science and Engineering,  
Visvesvaraya Technological University, India*  
E-mail: [rashmih@ksit.edu.in](mailto:rashmih@ksit.edu.in)

### *Abstract*

*Our primary objective is to show spatial-temporal alterations in human face recordings that are difficult or unfeasible to see with the bare eyes in an expressive manner. Eulerian Video Magnification [EVM] Is the technique developed that accepts a conventional video sequence as input and generates decomposition at spatial level and temporal filtering. Space is known as spatial. The term temporal relates to the passage of time. The resulting signal is subsequently amplified in order to disclose previously unnoticed data. We will be able to interpret the blood flow as it fills the face, as well as enhance and tell tiny motions, using our technology. Our method can be used in real time to depict events that occur at the user-selected temporal frequency.*

### *Keywords*

*Eulerian video magnification, Fourier Transform, photoplethysmography, image processing,*

## **1. INTRODUCTION**

The heart's function is so vital, the heart rate takes precedence. The heart pumps oxygenated and nutrient-rich blood around the body. The heart rate is one of the human body's "crucial indications," or key signals of health. It estimates the

number of contractions or beats per minute of the heart. The heart examination is one of the most common tests conducted in health care.

Without requiring physical contact, the suggested method will deliver heart rate information. Although the spatio-temporal sensitivity of the human vision is constrained, numerous signals that fall underneath this criterion are nonetheless detected and can provide useful or fascinating information. The colour of human skin, for example, varies or changes slightly as blood circulates. This fluctuation can be used to bring out pulse rate, even though it is not visible to the naked eye. We calculate accurate motion of the head.

To extract heart rate and beat durations from recordings, each time there is a motion in the vessels of our body. Our method involves looking at the colour values at each spatial location (pixel) in a time series, magnifying variation in a particular temporal frequency range. We pick a variety of temporal frequencies that spans a reasonable range of human heart rhythms, then add to it intuitively.

As blood circulates all over the face, the amplifiers let forth a variety of redness. Temporal filtering aims to remove or lower frequencies that aren't of interest from the raw signal. Filtering that takes place temporally must be utilised to some frequencies that lie on the lower space of the spacial bandwidth, accurate

# FACE MASK DETECTION

Mrs. Pavithra J<sup>1</sup>, Yashwanth K<sup>2</sup>, Sudhakar Yaswanth<sup>3</sup>, Prateek Havale<sup>4</sup>, Vinod H Malali<sup>5</sup>

<sup>1</sup>Assistant Professor, <sup>2,3,4,5</sup>Under Graduate Student  
Dept of Computer Science and Engineering,  
K S Institute of Technology,  
Bengaluru, Karnataka.

**Abstract**— Since December 2019, we have all been battling the Coronavirus (COVID-19). We are still (2022) fighting this virus. This virus frequently evolves into new variants, such as Delta, Omicron, and Covariant, infecting people all over the world. When an infected person coughs, sneezes, sings, or breathes, the virus spreads through their mouth or nose in small liquid particles. (COVID-19) has infected over 5.4 billion individuals worldwide, killing over 6.3 million people. Every one of us should wear a face mask to protect ourselves from the COVID-19 Pandemic. In most public meetings, such as schools, colleges, and malls, it becomes vital to check if people are wearing face masks. We must all take care to avoid getting the virus, such as wearing a mask, cleaning frequently, and maintaining social distance. Due to carelessness or negligence, some people will refuse to wear a mask. As a result, people must be reminded to wear masks. To address this issue, the "FACE MASK DETECTION" project was created using YOLOv4-tiny algorithm with Darknet repository. The model will identify persons who do not properly wear masks.

**Keywords**— Coronavirus (COVID-19), Delta, Omicron, Covariant, YOLOv4-tiny.

## I. INTRODUCTION

Coronavirus (COVID-19) disease is caused by the SARS-CoV-2 virus, which is an infectious disease. The symptoms of COVID-19 infection include fever, sore throat, cold, cough, and body pain. People over 65, as well as those with underlying medical conditions including diabetes, cancer, or lung disease, are at risk of serious illness. COVID-19 can affect people of all ages and can result in mortality at any age. The virus spreads in little liquid particles from an infected person's mouth or nose when they breathe, speak, sneeze, cough, or sneeze. The virus spreads through the air if infectious particles come into direct contact with the eyes, nose, or mouth. After coming into contact with virus-infected objects, people can be infected by touching their eyes, nose, or mouth.

To fight the coronavirus, many preventative steps have been implemented. Cleaning hands, keeping a safe distance, and wearing a mask are among them. Every one of us should wear a face

mask to protect ourselves from the COVID-19 Pandemic. In most public meetings, such as schools, colleges, and malls, it becomes vital to check if people are wearing face masks. This technique can be used to create a full-fledged software that scans everyone before allowing them to enter a public meeting.

To make the usage of a facemask mandatory, some method must be devised that forces people to put on a mask before entering public spaces. Face mask detection is the process of determining whether or not someone is wearing a mask.

Using the YOLOv4-tiny algorithm, this study provides a solution for determining if people are wearing masks properly or not. To achieve a model with a lower weight.

Face mask detection entails identifying the location of a person's face and then assessing whether or not they are wearing a mask. The problem is related to general object detection, which is used to identify different types of things. Face identification is the process of identifying a certain group of entities, i.e. faces. This model is implemented using YOLOv4-tiny algorithm with Darknet repository. Darknet repository make changes in the makefile to enable OpenCV and GPU to implement the model.

Face mask detection is a technique for determining whether or not someone is wearing a mask and where his face is located. The problem is linked to object detection in general, which identifies object types. The detection of a specific sort of object is known as face detection. This strategy can be used in a variety of settings, such as the military, defence, schools, colleges, and universities, planes, banking, online web apps, gaming, and so on. Face masks have become commonplace as part of normal virus-prevention efforts, particularly during the Covid-19 virus outbreak. Despite the fact that many academics have worked hard to develop fast algorithms for face detection and recognition, there is a significant difference between 'detection of the face under mask' and 'detection of mask over face.

The implemented model is very useful for detecting the face mask, by checking with and without mask, every person before they enter into the public gatherings. The creation of a system that can detect if

# Analyzing and Predicting Outcomes of IPL Cricket

Pavithra J<sup>1</sup>, Kilari Jaswanth<sup>2</sup>, Kencham Arun<sup>3</sup>, B Deva Deekshith<sup>4</sup>, Kilari Ashwik<sup>5</sup>

<sup>1</sup>Assistant Professor, Department of Computer Science and Engineering, K S Institute of Technology (Affiliated to VTU), Bangalore, Karnataka, India

<sup>2,3,4,5</sup>Student, Department of Computer Science and Engineering, K S Institute of Technology (Affiliated to VTU), Bangalore, Karnataka, India

<sup>1</sup>[pavithraj@ksit.edu.in](mailto:pavithraj@ksit.edu.in)

<sup>2</sup>[jaswanthkj2k18@gmail.com](mailto:jaswanthkj2k18@gmail.com)

<sup>3</sup>[arunkencham@gmail.com](mailto:arunkencham@gmail.com)

<sup>4</sup>[bdevadeekshith2000@gmail.com](mailto:bdevadeekshith2000@gmail.com)

<sup>5</sup>[kilariashwik22@gmail.com](mailto:kilariashwik22@gmail.com)

**Abstract**— The Indian Premier League (IPL) is a Twenty20 professional men's cricket tournament, of which 10 Teams compete from ten different locations. Millions of people especially Indians are obsessed with the Indians Premier League (IPL) and our work related to data analysis and match predictions for IPL matches. Over the years, analysis is used to predict and derive sports insights. IPL data analysis is everything about using data science, machine learning for analytics data already exists in the data set. Here The design of the Web Interface will be made for the purpose analyze IPL data by retrieving various attributes and building a predictive model that can predict the First Innings Score, Second Innings Score, and also Overall Performance of the Team.

**Keywords**—Cricket, Indian Premier League(IPL), Prediction, Machine Learning, Predictive Model.

## I. INTRODUCTION

The use of statistical analysis in sports has gradually increased over the years. Accordingly, the way the game framework methodologies are Measured has changed, but the crowd's interest in cricket has extended. Currently, cricket is one of the most-watched sports games on the planet. The Indian Premier League is the most famous T20 cricket association in the world. The association started in 2008 and was founded by BCCI. It is usually held in March and May every year. IPL is the most famous cricket association on the planet, 6th place among all sports associations related to normal participation in 2014. With a total of eight teams, each team faces an opponent twice in the tournament. In the final stage, only the beginning four teams qualified for the knockout round. The first two teams in the tournament will face off in the first match elimination match, the winner has promoted directly to the Ipl finals and losers get a second chance to play a second type match.

The Performance of the team depends on key players and their performance, team combinations and other important aspects should be taken into account. The goal of our work is to analyze the previous year's data and predict the

possible outcomes such as first innings score, second innings score prediction, and the winning percent of the respective teams according to the team combination. Our model also provides the current squad of each IPL team.

## II. LITERATURE SURVEY

[1] Nikhil Donge, Shraddha Dhol, Nikita Wavre, Mandar Pardakhe, and Amit proposed two models the first one is a prediction of the score and the second one is a team-winning prediction. In these, the score prediction Regression is more than Ridge and Lasso Regression and in winning prediction analysis among SVC, Decision tree classifier and Random forest classifier, they got random forest classifiers accuracy more than other 2, with all 90%, 80%, 75%, 70% training data.

[2] Praveen Banasode, Minal Patil, and Supriya Verma performed a work about the analysis of the data and predicting the IPL matches. IPL data analysis is all about analyzing the data that is present in the data set and the predicted player runs, and team winners. The algorithm used by them provided an accuracy of over 95%. They have collected datasets from Kaggle and espnricinfo.com which contains data from 2008 to 2019. This application can help in selecting the best players, bowlers, and fielders from each team and predict their future performance.

[3] Pallavi Tekade, Kunal Markad, Aniket Amage . Bhagwat Natekar prepared a machine learning model for predicting the outcomes of its matches. They have used Decision Tree, Random Forest Regression, Logistic Regression, and Naïve Bayes. They have taken 11 seasons datasets as a training dataset which consists of 580 matches. The highest Prediction accuracy is 90% and they have also briefs about the key factors that affect the result of the cricket match.



# An Innovative approach for air pollution control In India using Convolutional Neural Network.

1<sup>st</sup> K.Himalaya  
dept. computer  
science and  
engineering  
Bit Institute of  
Technology  
Hindupur,  
Anantapur  
[himareddy1612@gmail.com](mailto:himareddy1612@gmail.com)

2<sup>nd</sup> K.Mamatha  
dept. computer science  
and engineering  
Bit Institute of  
Technology  
Hindupur,  
Anantapur  
[mamathak472000@gmail.com](mailto:mamathak472000@gmail.com)

3<sup>rd</sup> KH.Vaibhav  
Kumar  
dept. computer science  
and engineering  
Bit Institute of  
Technology  
Hindupur,  
Anantapur  
[vaibhavkumar2058@gmail.com](mailto:vaibhavkumar2058@gmail.com)

4<sup>th</sup> M.Hari  
dept. computer science  
and engineering  
Bit Institute of  
Technology  
Hindupur,  
Anantapur  
[manchepallihari2000@gmail.com](mailto:manchepallihari2000@gmail.com)

5<sup>th</sup> Somasekhar  
Dept. computer science  
and engineering  
K.S Institute of  
Technology,  
Bangalore  
[somasekhar@ksit.edu.in](mailto:somasekhar@ksit.edu.in)

## Aim:

The main aim of this system is to propose a general and effective approach to predict the air quality and give suggestion which will create the impact on society.

## Abstract:

The interpolation, prediction, and feature analysis of fine-gained air quality are three important topics in the area of urban air computing. The solutions to these topics can provide extremely useful information to support air pollution control, and consequently generate great societal and technical impacts. Most of the existing work solves the three problems separately by different models. In this paper, we propose a general and effective approach to solve the three problems in one model called the Deep Air Learning. The main

idea of DAL lies in embedding feature selection and semi-supervised learning in different layers of the deep learning network. The proposed approach utilizes the information pertaining to the unlabeled spatio-temporal data to improve the performance of the interpolation and the prediction, and performs feature selection and association analysis to reveal the main relevant features to the variation of the air quality.

## Introduction:

The interpolation, prediction, and feature analysis of fine-gained air quality are three important topics in the area of urban air computing. A good interpolation solves the problem that there are limited air-quality-monitor-stations whose

# MENTAL DISEASE PREDICTION IN BRAIN IMAGES USING DEEP LEARNING

<sup>1</sup> Muliati Bhanu  
Prakash Reddy  
dept. computer science  
and engineering  
Bit Institute of  
Technology  
Hindupur, Anantapur  
[mbhanuprakash1052000@gmail.com](mailto:mbhanuprakash1052000@gmail.com)

<sup>2</sup> K E Sowmya  
dept. computer science  
and engineering  
Bit Institute of  
Technology  
Hindupur, Anantapur  
[sowmyak1311@gmail.com](mailto:sowmyak1311@gmail.com)

<sup>3</sup> Uzma Parigi  
dept. computer science  
and engineering  
Bit Institute of  
Technology  
Hindupur, Anantapur  
[uzuuzma34@gmail.com](mailto:uzuuzma34@gmail.com)

<sup>4</sup> Amanulla Bettal  
dept. computer science  
and engineering  
Bit Institute of  
Technology  
Hindupur, Anantapur  
[bamanulla5@gmail.com](mailto:bamanulla5@gmail.com)

<sup>5</sup> T Somasekhar  
Dept. computer science and  
engineering  
K.S Institute of Technology,  
Bangalore  
[somasekhar@ksit.edu.in](mailto:somasekhar@ksit.edu.in)

## ABSTRACT:

Neuroimaging-based approaches have been extensively applied to study brain disease in recent years and have deepened our understanding of both cognitively healthy and disordered brain structure and function. Recent advancements in machine learning techniques have shown promising outcomes for individualized prediction and characterization of patients with psychiatric disorders. Studies have utilized features from a variety of neuroimaging modalities, including structural, functional, and diffusion magnetic resonance imaging data, as well as jointly estimated features from multiple modalities, to assess patients with heterogeneous brain disorder such as schizophrenia and bipolar disorder. The proposed method is used to predict whether the patient have any brain disease or not along with illness types like schizophrenia and bipolar disorder, using deep learning models CNN and VGG16. The performance matrices like accuracy is used to compare both the model to show which one is better.

## SCOPE OF THE PROJECT:

1. Brain disease such as schizophrenia and bipolar

disorder are highly prevalent and have been shown to impact an individual's physical health.

2. We predict the mental stability of people, by using the features from brain neuroimages.
3. The analysis is to predict whether the people have any mental stability issues or not along with type of illness.

## EXISTING SYSTEM

The machine learning algorithm trained with structural MR images detected schizophrenia in randomly selected images with reliable performance (area under the receiver operating characteristic curve [AUC] of 0.96). The algorithm could also identify MR images from schizophrenia patients in a previously un encountered data set with an AUC of 0.71 to 0.90.

The deep learning algorithm's classification performance degraded to an AUC of 0.71 when a new data set with younger patients and a shorter duration of illness than the training data sets was presented. The brain region contributing the most to the performance of the algorithm was the right temporal area, followed by the right parietal area. Semi trained clinical

# A Dictionary-based methodological approach for early prediction of Diabetes using Machine Learning models

E. Sreehari<sup>1</sup>, B. Ramesh<sup>2</sup>, T. Somasekhar<sup>3</sup>, E. Reddy prasad<sup>4</sup>

<sup>1</sup>PG Scholar, SITE, VIT University, Tamilnadu, sreehari.0088@gmail.com

<sup>2</sup>PG Scholar, SITE, VIT University, Tamilnadu, rameshmtehnitt@gmail.com

<sup>3</sup>Assistant Professor, KSIT Bengaluru, Somu4ever@gmail.com

<sup>4</sup>Consultant AI/ML @Sumeru Solutions Pvt Ltd, reddyprasade@gmail.com

## Abstract

Diabetes means an abnormality in the whole human body. Diabetes generally occurs when the pancreas does not produce the required insulin. India has the greatest number of diabetes people in the second position compared to other countries. Probably as per the reports of the Indian institute of public health director the number of diabetes patients in our country may rise to 120 million coming the next 20 to 25 years. Diabetes leads to other complications such as heart, kidney failure, vision, pain, or cramps in different parts of the human body. So, it is very necessary to control and predict diabetes at an early stage which would be useful for early-stage treatment and to save one's life as well. Here to predict whether the candidate has diabetes or not we implemented a dictionary-based approach with multiple machine learning models. We applied our proposed method to the early-stage diabetes risk prediction dataset. Random forest and Gaussian process classifier performed well in terms of accuracy, recall, F1 and kappa score performance evaluation metrics

**Keywords:** Diabetes, Neuropathy, Retinopathy, Matthews Correlation Coefficient, Kappa score.

## 1. Introduction

According to experts, diabetes is a chronic disease that generally occurs when the pancreas is not able to produce enough insulin. Approximately globally 422 million people struggling due to diabetes [1] and in the future may rise to 622 million also [2]. Different types of diabetes existed according to Essam and generally type 1 and type 2 diabetes [3]–[5]. Few countries are on top in terms of diabetic prevalence and reached top positions globally [6]. High diabetic levels lead to complications pain or cramps in different parts of the human body [7].

- Kidney failure
- Heart failure

- Neuropathy (Nerve damage)
- Retinopathy (Vision Impairment)
- Fatigue, Foot Ulcers
- Skin and digestion-related problems

The figure will reach 640 million by 2040 so it is very necessary to control diabetes either by regular monitoring or early diabetic prediction [8]. Prediction of diabetes at an early stage can lead to improved treatment and is useful for the Diagnosis of Diabetes Mellitus [9]. According to Healthline [10], various reasons are contributing to the rise in diabetes levels such as

- ✓ Less physical activity
- ✓ Smoking at higher rates
- ✓ Increased insulin resistance
- ✓ Increased refined white rice consumption
- ✓ The high Pollution index rate
- ✓ Due to a lack of effective food habits and control
- ✓ Taking poor nutritional food resources

Early prediction of diabetes is very necessary to control and predict diabetes at an early stage which would be useful for the early-stage treatment and to save one's life as well. Doing this work helps to know risk factors [11]. For diabetes type 1 and type 2 regular monitoring and controlling could be possible [1]. Here in this paper, we implemented a dictionary-based approach using multiple machine learning models. We applied our proposed method to the early-stage diabetes risk prediction dataset. In this research paper, diabetes is predicted using significant attributes, and the relationship of the differing attributes is also characterized.

The rest of the paper is structured as follows section discussed methodology and data set description. In section 3 we put up obtained results and graphs. Conclusion and future work are defined in section 4.

## 2. Methodological structure

NEW AGE

**ENGINEERING**

**ENGINEERING  
STATISTICS  
AND  
LINEAR ALGEBRA**

**MAMATHA A S  
BHARGAVI ANANTH  
SHYLASHREE N  
V SRIDHAR**



**NEW AGE INTERNATIONAL PUBLISHERS**

# ENGINEERING STATISTICS AND LINEAR ALGEBRA

**MAMATHA A S**

*Associate Professor*

Department of Electronics and Communication Engineering  
St. Joseph Engineering College, Vamanjoor  
Mangaluru - 575028

**BHARGAVI ANANTH**

*Assistant Professor*

Department of Electronics and Communication Engineering  
KS Institute of Technology  
Bengaluru - 560 060

**SHYLASHREE N**

*Associate Professor*

Department of Electronics and Communication Engineering  
RV College of Engineering®  
Bengaluru - 560 059

**V SRIDHAR**

*Emeritus Professor*

Department of Electronics and Communication Engineering  
Nitte Meenakshi Institute of Technology  
Bengaluru - 560 064

*Committed to Educate the Nation*



*Publishing Globally*

**IN INDIA**

**NEW AGE INTERNATIONAL (P) LIMITED, PUBLISHERS**

**LONDON • NEW DELHI**

Bangalore • Chennai • Cochin • Guwahati • Hyderabad • Kolkata • Mumbai

Visit us at [www.newagepublishers.com](http://www.newagepublishers.com)

# Machine Learning Techniques for Cardiovascular Risk Score –Prediction

Jayasudha B S K, P N Sudha, Rachana S, Sahana, Anagha A Kashyap, Anusha L  
K S Institute of Technology  
Bangalore, India

jayasudhavijay@ieee.org, pnsudha@ksit.edu.in, rachanas05710@gmail.com

**Abstract**—Cardiovascular diseases (CVD) are termed to be the group of diseases related to the human heart, which are very dangerous and risky. It affects human life on various levels depending upon its complexity rate. Various Machine Learning (ML) techniques have been on the top of the list to evaluate the cardiovascular risk. Different factors such as age, height, blood pressure, smoking habits, cholesterol levels etc have been considered in risk analysis. Many clinical parameters have been looked out thoroughly along with the variations in the ECG signals and other heart related conditions in humans to evaluate and determine the CVD risk factors. The risk that a particular person will be prone to, in the next 10 years will be determined by considering the above-mentioned factors. Vital parameters dataset and few parameters of ECG signals are used carefully in the prediction process to build a well-defined machine learning based CVD risk score model. Established machine learning algorithms, feature selection algorithms and classifiers such as random forest and naive bayes are used. The performance metrics of the models are compared. The risk that the person is prone to, is divided into low, moderate, and high. The features that are extracted from the ECG are used to feed the predictors. Neural networks outperform other models with 97% accuracy. The proposed machine learning based models will play a major role in assisting the doctors in diagnosing the CVD.

**Keywords**—Confusion matrix (CM), cardiovascular disease (CVD), Electrocardiography (ECG), Machine learning (ML).

## I. INTRODUCTION

Health stands to be one of the most important aspects in the society. Humans have been prone to various diseases and health problems [1]. Especially when we consider the area of CVD, people need to pay more attention to what and why they are prone to. Looking keenly into the history of person's medical background and with timely examination, the health status of a person can be accurately diagnosed [2]. The mortality rate in humans has been increasing at a greater rate due to cardiac risk. So, it makes an irresistible condition to look into the symptoms and pay more attention to the part of predicting the risk [3]. Some of the major habits and factors such as diabetes, smoking, hypertension have become more common in 5-6 among group of 10 individuals of the current population [4]. It has been an important and necessary factor to inculcate the process of diagnosis of disease at early stage and predict the risk score [5]. Datasets are collected from IEEE data port

and datahub. Vital parameters and ECG data are used in the process of risk stratification. The main goal behind this is to assess the cardiac risk score as low, moderate, and high.

## II. LITERATURE SURVEY

The Framingham Heart Study's available database is utilized to research CVD risk factors. From the perspective of clinical practice, it is one of the most essential CVD Prediction tools. Because of the benefits that machine learning will bring up new predictive models, it has been decided to test alternative algorithms to determine how far their findings would improve on the original Framingham model's outcomes. Different machine learning techniques, such as decision trees, support vector machines, random forests, neural networks, and logistic regression, were studied methodologically and their findings compared [6]. The primary goal of this research is to compare the accuracy of several machine learning methods. For comparison with other algorithms, output variables such as Accuracy, Precision, and Recall were chosen. Two separate datasets, such as test data and train data, were produced for the algorithm comparison. The ML algorithms that were applied to FRS parameters (data) yielded results that were equivalent, if not superior, to those presented in the original Framingham coronary risk scale article [7].

ECG is a tool/procedure that uses electrodes to monitor the heart rate and identifies minor electrical changes for each heart rate. It is used to detect abnormal cardiac function, such as arrhythmias. In the case of cardiovascular disease, early identification is critical [8]. It is made up of three waves: P wave, QRS wave, and T wave. It is formed as a result of the heart's atria and ventricular functions. Using a neural network built with multilayers and having the functionality of error back propagation, the ECG signal is categorized as normal or abnormal [9].

Two datasets are evaluated with two NN structures. The ECG signal is classified and detected using a fuzzy logic neural network [10]. The ECG signal is classified using a specified methodology and a classification approach. The input signal is pre-processed to remove high-frequency noise using filtering. After pre-processing, a peak detection method is employed to locate peak points, and statistical parameters are used to extract signal attributes [11]. To categorize the ECG database as normal or abnormal, multiple ML algorithms such as SVM, ANN, and

# Real-Time Face Detection and Recognition on Raspberry Pi using LBP and Deep Learning

Venkata Kranthi B<sup>1†</sup>

<sup>1</sup>ECE Department, GITAM University,

<sup>†</sup>K.S.Institute of Technology, VTU

Bengaluru, Karnataka, India

bvkranthi1@gmail.com

Surekha Borra<sup>2</sup>

ECE Department

K.S. Institute of Technology,

Bengaluru, Karnataka, India

borrasurekha@gmail.com

## ABSTRACT

Advancement in low power embedded systems in recent years help us in building portable real-time algorithms and applications. These embedded systems can be integrated into the Cameras used in Surveillance Systems to provide additional mid-level computer vision tasks like face detection and face recognition in person identification applications. This paper proposes face detection using Local Binary Patterns (LBP) and Haar cascades-based face recognition using Convolutional Neural Networks (CNN) derived from Lenet architecture. A database is created covering all challenges involved in face identification like illumination, orientation, expressions, disguise, and age factors. Two CNN architectures are proposed and compared for face recognition. The tasks are performed on Raspberry Pi in real-time, and analysis has been carried out on how well LBP and Haar cascades work in terms of accuracy and Frames per second (FPS) in real-time. The real-time results achieved are acceptable with the frame rate of 7.04 FPS with accuracy above 94%. Frame reading and frame processing are handled in separate threads on CPU and frame skipping, while detection and recognition have improved the frame rates significantly.

## CCS CONCEPTS

• Computing methodologies • Machine Learning

## KEYWORDS

Face Detection, Face Recognition, CNN, Deep Learning, Raspberry Pi

Permission to make digital or hard copies of all or part of this work for personal or classroom use is granted without fee provided that copies are not made or distributed for profit or commercial advantage and that copies bear this notice and the full citation on the first page. Copyrights for components of this work owned by others than ACM must be honored. Abstracting with credit is permitted. To copy otherwise, or republish, to post on servers or to redistribute to lists, requires prior specific permission and/or a fee. Request permissions from [Permissions@acm.org](mailto:Permissions@acm.org).  
DSMLAI '21, August 9–12, 2021, Windhoek, Namibia  
© 2020 Association for Computing Machinery.  
ACM ISBN 978-1-4503-8763-7/20/06...\$15.00  
<https://doi.org/10.1145/3484824.3484903>

## 1 Introduction

The Human recognition on an embedded platform is a beneficial and highly recommended application for making intelligent surveillance cameras and human identification systems by Vidyasree et al. [1]. The recognition process includes detecting a face in a frame from a distance and then recognizing it in real-time without her/his involvement. New generations want portable devices that can perform many real-time jobs to help them in daily life. Surveillance system is where one needs an embedded platform for portability Surekha et al. [2]. Surveillance applications require the right amount of computational power, a lot of hardware equipment, and complex algorithms at the server end. The embedded platform is an added advantage for the existing surveillance by doing most computer vision tasks at the camera and providing the summary to the server over the network, making it an intelligent surveillance system by Chaudhry et al. [3]. The server's load is reduced, and the system's scalability is increased since extra surveillance cameras can be added under a single server. The low-power, low-cost platform designed for education [4,5,6], Raspberry pi, has drawn attention to the implementation of applications not limited to general-purpose computers only. Nakajima et al. [7] experimented the traditional LBP histograms and deep learning CNN based face recognition approaches on Raspberry pi.

Some of the real-time, hardware-based solutions for face detection and recognition are provided here. Bilaniuk et al. [8] implemented face detection using LBP on Single instruction, multiple data (SIMD) device at 5 VGA frames per second with low power consumption. Soetedjo et al. [9] proposed face detection on raspberry pi with Raspi-cam in real-time using a combination of Haar cascades, camshaft. Tripathy et al. [10] implemented face tracking using a pan-tilt camera which can be controlled using Raspberry pi by performing face detection. Janard et al. [11] proposed the controlling pan-tilt unit of telepresence robot made using Raspberry pi with an android smartphone. Suja et al. [12] implemented recognition of emotions such as anger, sad, surprise etc., instead of the only face. Face expressions were recognized by using LBP and Haar cascades by Pravallika et al. [13]. Scrgin et al. [14] used LBP combined with other image processing techniques in order to improve the recognition performance and was able to

# A Hybrid Reversible Image Watermarking Technique based on Fractal Encryption and Grey Wolf Optimization

Lakshmi H R  
Dept. of ECE, VTU Research Center  
K S Institute of Technology  
Bengaluru, India  
hr.lakshmi@gmail.com

Surekha Borra  
Dept. of ECE  
K S Institute of Technology  
Bengaluru, India  
borrasurekha@gmail.com

**Abstract**—To improve robustness and imperceptibility of watermark, a new hybrid image reversible watermarking technique is proposed in the research paper on the basis of fractal encryption and Modified Quadratic Difference Expansion (MQDE). At first, fractal encryption with L shaped tromino theorem is applied to the watermark (secret image) for improving the security of data transmission with limited system complexity. Further, Grey Wolf Optimization (GWO) is used for optimizing the block assignment to imbibe the secret image into cover (host) image that significantly improves the visibility. Finally, MQDE technique is used for improving the embedding rate and visual quality of watermarking. Experimental metrics validate proposed technique is superior to existing models in light of robustness against noise, cropping attacks, rotation and histogram equalization. It also shows satisfactory imperceptibility. The proposed model retrieves the original cover and secret image without losing the essential information and delivers optimum security.

**Keywords**— embedding strengths, fractal encryption, grey wolf optimization, modified quadratic difference expansion, reversible digital image watermarking

## I. INTRODUCTION

In light of vast expanse of internet and the mobile devices, digital images are frequently collected, shared and stored on social networks like Instagram, Facebook, WhatsApp, Twitter etc. Usually, the digital images are uploaded to the internet directly without any protection technique [1-4]. However, it leads to a few concerns like counterfeit, illegal copy, redistribution of multi-media data and ownership verification [5-8]. To address these problems, digital watermarking is extensively used to verify the integrity, copyright protection, inheritance certification and legal evidence protection. Digital watermarking technique involves two mechanisms: embedding and extraction, which need to meet three crucial properties: imperceptibility, capacity, and robustness [9-11]. The watermark or secret image which contains owner's private information is encoded into host image in the "embed" phase. It is retrieved from the embedded image in the "extraction" phase to retrieve the secret information for precise authentication [12-14].

In watermarking, when the watermark is imbedded in the host, some pixels are altered in the host image. These changes, however unnoticeable they may be, are unacceptable in sensitive applications like defense, medical imaging, forensics etc.[15][16]. Based on whether the host can be extracted after watermark retrieval or not, image

watermarking can be grouped as non-reversible watermarking and reversible watermarking.

The purview of this paper is on Difference Expansion (DE) based reversible watermarking (RW) techniques, which meets requirements of improvement in embedding capacity and visual quality.

## II. RELATED WORK

Tian et. al [17] presented Difference Expansion (DE) for the first time. The method chooses pair of pixels and calculates difference values of these pixel values out on which, some are used for embedding the watermark and related auxiliary data. In [18], Tian et. al, proposed DE based RW where the pixels are not compressed for hiding the watermark data. The method exploits the similarity in consecutive pixel regions. Such regions are used to expand the calculated difference values and hide the watermark bits[19]. A DE scheme based on double directional embedding [20] is proposed to increase the payload. The payload is further improved as there is no need for a location map. Embedding is achieved in double layers [21] to improve the capacity. A map of locations comprises of the index of the changeable pair. This is further compressed and embedded as payload. Image quality was improved by using three thresholds [22]. The standard deviation values are correlated with values of pixels. However this is a fragile scheme. Negative difference values [23] are also considered for expansion using modulus to improve the capacity. Variable block sizes [24] were used for difference calculation and a fixed point (base) was referenced for difference calculation. The capacity was improved through reducing the difference further. A DE based RW scheme is proposed [25] for video signals. There is a feedback mechanism for selection of a suitable threshold value through iterations until a satisfactory value of PSNR is attained. Reduced DE (RDE) is an up gradation of DE based technique where difference is reduced before embedding to improve the bit rate. An RDE scheme was proposed [26] for data insertion in multiple layers. A pixel was chosen as the base in each layer. The method improves capacity by arbitrating the pixel disposition in each layer. A hybrid scheme based on combination of DE and RDE is proposed [27] for improving the SSIM in non-smooth areas for medical images. The method uses non-overlapping blocks to divide the cover image. Differences are reduced using [28] for non-smooth blocks and data is embedded using [17]. For embedding smooth blocks, wavelet transform method [24] is used. A DE scheme based on clusters [29] improves the payload capacity. Clusters are formed using a fixed formula



# Evaluation of Machine Learning Models for Real-Time Sign Recognition

Sirisha M  
Department of ECE  
K.S.Institute of Technology  
Bangalore, India  
sirisha1052000@gmail.com

Vishal Goutham N  
Department of ECE  
K.S.Institute of Technology  
Bangalore, India  
vishal211299@gmail.com

Sanjana B  
Department of ECE  
K.S.Institute of Technology  
Bangalore, India  
sanjanabudarinath2000@gmail.com

Surekha Borra  
Department of ECE  
K.S.Institute of Technology  
Bangalore, India  
borrasurekha@gmail.com

**Abstract**—Development of a real-time sign recognition system is a critical step in enabling communication between the speech impaired and normal individuals. This paper proposes a vision-based model for sign recognition using Machine Learning models. A local dataset is created by capturing the images under various light and background conditions by employing a webcam. AlexNet architecture and MATLAB are used to extract the features from captured images and to train several Machine Learning models for their performance evaluation. The images captured in real-time are processed to extract the features and then are directed to the classifier to predict the Sign class. The text to voice conversion module plays the speech based on the output of the classifier. An accuracy of 91.7 % is achieved with Support Vector Machine (SVM) learning model on the private dataset. Sign recognition with the proposed model is more reliable and cost-effective when compared to non-vision based approach.

**Keywords**—Machine Learning, MATLAB, Sign Language, Sign Recognition, Vision-based

## I. INTRODUCTION

Communication plays a significant role in building one's life. Unfortunately, verbal communication for speech-impaired people becomes a barrier in articulating their ideas. Hence, they use sign language to communicate with others. But understanding sign language becomes challenging for ordinary people. Consequently, disabled people face difficulties in conveying things. An interpreter is required to translate the sign languages [1] for resolving this problem. Since there is no universal sign language, it becomes difficult to have an interpreter who knows all the sign languages. There are two automatic approaches mentioned in the literature to bridge this communication gap: vision-based and non-vision-based sign language translation systems.

Non-vision technique uses a wearable hand glove to recognize Signs. The system measures the changes in the resistance and hand orientation using flex sensors and accelerometers mounted on the glove. The output from these sensors is then processed by the microcontroller, to obtain the text and speech output based on the Sign. Vision-based systems [2] involves a human-machine interaction to make

communication efficient and feasible. A camera is employed to capture the signs, and the Signs are recognized using computer vision and Machine learning techniques [3]. In non-vision-based methods the circuit is more complex and might get damaged easily [4]. Also, it is expensive, and user may not feel comfortable in wearing the hand glove for longer durations.

A vision-based method is proposed in this paper, which is user friendly, cost effective and more reliable. The model performed effectively when tested under various illuminations, backgrounds and for different hand sizes and skin tones.

## II. RELATED WORK

Bantupalli et al. [5] proposed a vision-based technique that uses iPhone 6 camera to capture the videos for the American Sign Language (ASL) dataset at 60fps. Signs are recorded with a full-sleeved shirt. Each video is broken down into several image frames. Later these image frames are augmented to expand the dataset. The user's hand Sign is recorded through a camera and the videos are preprocessed before feeding to the CNN inception model extraction of the temporal features from image frames. LSTM (Long short-term memory) classifies the segmented Signs into one of the Sign classes. The trained LSTM compares the results of SoftMax and global pool layers of the CNN. The system trained both the CNN and RNN techniques independently but failed to differentiate the skin tone. Also, the accuracy dropped due to the inclusion of faces because of variation in faces. The variation in clothing led to poor performance. Cross entropy cost function based on adaptive moments was used to minimize the loss. The model efficiency would have improved by isolating the hand Signs from the images using the ROI technique.

Athira et al. [6] proposed a single-handed dynamic sign identification with co-articulation elimination. Each recognition block is composed of sub-blocks to pre-process, extract the features, and classify the images. The system captures dynamic Signs using a web camera at a frame rate of 15fps. For a continuous Sign sequence, two successive signs are segregated with some fluctuation in gesticulation known as co-articulation, which is not considered for recognition.



# Real-Time Piracy Detection Based on Thermogram Analysis and Machine Learning Techniques

B. Sanjana<sup>✉</sup>, M. Sirisha, Pruthvi Dinesh, G. R. Sunil Kumar, and Surekha Borra

Department of ECE, K. S. Institute of Technology, Bangalore, Karnataka, India  
sanjanabadarinath2000@gmail.com

**Abstract.** Movie Piracy is increasing these days, and it has a profound impact on the economic growth of film industries all over the world. Hence curbing piracy has become a critical step in avoiding massive losses to the film industry. This paper proposes a thermogram based anti-piracy system using Machine learning models. A local dataset is created by capturing the images in different scenarios by employing a thermal camera. AlexNet is used for extracting the features from captured images and the extracted features are trained with several Machine Learning models in MATLAB for their performance evaluation. The images captured in real-time are processed to extract the features and then directed to the classifier to predict the anomaly class. The alert message is sent to theatre officials regarding the presence of active recording device. An accuracy of 99.7% is achieved with Support Vector Machine (SVM) model on the local dataset.

**Keywords:** Camcorder · Movie piracy · Thermogram · AlexNet

## 1 Introduction

Cinema piracy is emerging as the biggest threat to the Film Industry in recent years. It has grown tremendously, making it easier than ever to access pirated movies on online platforms at one's fingertip. An increase in piracy has a severe impact on the economic growth of film industries all over the world. It is inferred from a survey that pirated videos receive over 230 billion views every year. As well, a study says that in the United Kingdom, about 30% of the population watch pirated movies, costing the industry £500 million every year. In India, piracy is considered as an offense, and pirates are prisoned for three years with a penalty of 10 lakh rupees as per the Cinematograph Act of 2019. Apart from this, filmmakers, producers, independent creators, and distributors lose interest in making sequels and remakes. Lower-class artists risk their job, welfare, and pensions.

The illegal copying of movie for the purpose of selling it at a lower market price is referred to as movie piracy. Some of the ways in which piracy can occur are Camera recording, DVD & VOD ripping, Telesync, Digital distribution copy, Telecine, and WEB-DL. Camcorder piracy can be classified into pre-release and post-release piracy. In pre-release piracy, the movie is pirated during exclusive screenings to sponsors, reviewers,

# Fingerprint Based Voting System

*NIDHIS*  
Dept. of Electronics &  
Communication Eng.  
K S institute of technology  
Bangalore, INDIA

*NISARGA K*  
Dept. of Electronics &  
Communication Eng.  
K S institute of technology  
Bangalore, INDIA

*N ANILA*  
Dept. of Electronics &  
Communication Eng.  
K S institute of technology  
Bangalore, INDIA

*MONISHA B K*  
Dept. of Electronics &  
Communication Eng.  
K S institute of Technology  
Bangalore, INDIA

*Dr. P N SUDHA*  
Prof. Head ECE dept.  
Dept. of Electronics &  
Communication Eng.  
K S institute of technology  
Bangalore, INDIA

**Abstract**—India, as we know it's the world largest democratic country and tint of the democracy lies in the citizens of the country to select or choose their own representatives. But nowadays, the genuine or the far election process are facing a lot of chaos in the fake voting, cheating, rigging and manipulating the voting machines, etc. We being the responsible engineers, it is our right to do something very useful to quite this kind of menace. In the commonly used electronic voting machines, the voting procedure takes place by electronically where this practice eliminates the usage of the ballot papers to caste the vote as in earlier times, because this is very much time consuming and there are chances of detecting many errors by purpose or accidentally. So, in these recent times the authentication of the person is very important and here it is based on the fingerprint. Hence the moto of this proposed paper is to have **ONE PERSON AND ONE AUTHENTICATED VOTE**. In the present working, finger print prototype based on the biometric voting machine with OTP authentication is developed.

**Keywords:** fingerprint, Biometric, authentication, vote

## INTRODUCTION

Voting is the right to each and every citizen of a country to cast their vote and to elect a leader. India is the democratic country and every citizen in the country have the right to vote and show their opinion amongst the leaders. The citizens of the country also have the right to change the ruling party. These can be done through the elections. Elections in the earlier times was carried out by the ballot papers. These ballot papers were not very much secured because it did not have any privacy, people could manipulate the votes which was voted by the voters. So, to avoid all these the electronic voting machine was brought into practice. this for some time was helpful in earlier and as days passed this also dint effect the system much therefore the idea of the fingerprint-based voting system came into effect because the system of voting in this project is based on the fingerprint, where these fingerprints cannot be manipulated by others as the fingerprint differs from one person to another. Hence, this would be of higher security and would have lot of privacy in

terms of voting, and the information or the details of the voter will be priorly saved and stored in the data base before the casting of the votes by the voters, it also checks if the voters have been voted earlier or not because one finger print and there should be one vote. If the person's data based is not stored earlier it fetches the information saying the matches is not found. All this is done by the Arduino controller.

## II. LITERATURE SURVEY

If the fingerprint matches, then the system checks whether that person has voted before, for the same election. If he has not voted then "Fingerprint and Aadhaar number matches. Cast vote" message be displayed. After voting, the register will be incremented. If that person has voted before, then "already voted" message is displayed along with a buzzer sound. This system will ensure a more secure voting process surely, which is quite required for the overall growth of a developing nation. The fingerprint-based voting system that has been proposed in this paper is faster and more efficient than the systems.[3] A very high level of security will be established by abstaining from rigging and any other kind of fake votes. Moreover, before casting the vote, the machine will check if the person voting is registered with the Election Commission database or not; by making sure that his finger print matches with the one that is already existing thus avoiding fake votes. This paper reduces the time taken to announce the result. Here, the system is made more secure by introducing biometric and Aadhaar number verification. This system allows one person to vote only once. Multiple voting is not allowed. This system can be used for postal voting also.[4]

# A Smart Wheelchair with an E-Health Monitoring System for the Elderly

Suraj V Ghorpade  
Dept of ECE  
K S Institute of Technology  
Bangalore, India  
surajghorpade748@gmail.com

Dr. PN Sudha  
Dept of ECE  
K S Institute of Technology  
Bangalore, India  
pnsudha@ksit.edu.in

Thanushree D  
Dept of ECE  
K S Institute of Technology  
Bangalore, India  
thanushreed04@gmail.com

Vaishnavi G  
Dept of ECE  
K S Institute of Technology  
Bangalore, India  
vaishnavigurunath01@gmail.com

Vrindha Sham Bhatt  
Dept of ECE  
K S Institute of Technology  
Bangalore, India  
vrindha99@gmail.com

**Abstract**— Individuals with disabilities and the elderly confront challenges when it comes to autonomous movement. They are primarily reliant on other people. The article provides a technique that allows them to move about independently while giving many controls that may be utilized in various contexts. The E-Health monitoring system checks their health in real-time using various wearable sensors and sends this data to the designated caretaker at regular intervals. Individuals' databases are also preserved in databases since they will be useful in assessing their health in the long run.

**Keywords**—Pulse rate sensor, Temperature sensor, Joystick, Voice Controlled, Arduino, IoT, ECG, Web Application, Health Monitoring

## I. INTRODUCTION

The main goal of this project is to build a smart wheelchair that will facilitate the elderly and helpless patients with minimal effort for locomotion, as well as to constantly monitor the general health through a wearable device with implanted sensors and an App designed to access the data to keep track of all health variations. A mechanism has been built to allow for easy movement in a variety of climatic situations. This enables persons with disabilities to carry out daily duties with little reliance. This study describes the design and implementation of a voice-controlled smart wheelchair for handicapped individuals.

## II. LITERATURE SURVEY

[1] In this paper titled, "Design and Fabrication of a Voice Controlled Wheelchair for Physically Disabled People", a voice recognition system is used to trigger and steer the wheelchair's movements. A microprocessor, microphone, voice recognition processor, and motor control interface board are used to propel the wheelchair. Simply speaking through the wheelchair microphone allows you to operate the wheelchair. A PIC controller from Microchip Technology controls the system's functionality. This project was created on a shoestring budget. Certain changes, however, are required to make this system more trustworthy. This concept might be improved by implementing a wireless connection and

employing sensors to detect impediments in the wheel chair.

[2] This paper titled, "IoT Based Emergency Health Monitoring System", This paper shows a system that uses IoT to continuously monitor a patient's body. This device will take physiological characteristics from the patient's body every 15 seconds. This system is in charge of collecting the patient's pulse, body temperature, and heart rate and transmitting the information to an IoT Cloud platform through WIFI-Module, where the patient's health condition is recorded. Precision, sensor count, and cost usefulness are all constraints. It is tough to analyze and determine a patient's health state with only three indicators. As a result, a greater number of sensors are necessary, and high-quality sensors are expensive. The system's lack of precision, on the other hand, might be overcome by utilizing more accurate and high-quality sensors.

[3] This paper titled, "An IoT based Patient Health Monitoring System", The system's goal is to monitor patients' health by employing a temperature and cardiac sensor. Both sensors are attached to the Arduino-uno. The microcontroller is linked to an LCD display and a wireless link to send data to a web server in order to maintain track of the patient's health. An IoT alert is given to the patient if there are any sudden changes in the patient's heart rate or body temperature. This system also makes use of the Internet to provide real-time temperature and heartbeat data for patients, complete with timestamps. This system is still in use according to conformist system, but it is extremely tough to manage individually, and size and cost are also more related with the upgraded system, and getting the proper result takes more than 1 minute. This technology delivers more medical instrument facilities on a single system on-chip than a conventional system.

[4] This paper titled, "Design and Development of a Smart Wheelchair with Multiple Control Interfaces" This study discusses the design and development of a smart wheelchair with several control interfaces. A smart wheelchair system prototype was developed based on a

# Real Time Fruit Detection and Classification using Image Processing and Convolution Neural Network

Charan G  
Department of Electronics and  
Communication Engg.  
K.S Institute of Technology  
Bengaluru, India

Dheeraj M S  
Department of Electronics and  
Communication Engg.  
K.S Institute of Technology  
Bengaluru, India

Ganesh P  
Department of Electronics and  
Communication Engg.  
K.S Institute of Technology  
Bengaluru, India

Dr. P N Sudha  
Professor. & Head  
Department of Electronics and  
Communication Engg.  
K.S Institute of Technology  
Bengaluru, India

**Abstract**—Object detection is the most prominent technological advancement in recent years. The advances in deep learning and image processing make it possible to recognize single and multiple objects in an image. Object detection along with deep learning can be used to build an automated system that can be implemented to perform various tasks like detection, classification, object counting, etc., in various domains. In this paper we propose a refined CNN method to perform fruit detection, ripeness classification, fruit counting, and estimate the calorie of the fruits present in an image. Here we are using VGG architecture to classify the image and localize the objects (in this case fruits). The number of fruits detected and classified is based on the data sets used for building the model.

**Keywords**—Object detection, image classification, CNN, VGG, Raspberry Pi, Deep Learning (DL), Fruit detection

## I. INTRODUCTION:

Artificial intelligence (AI) is a compound product of Machine Learning (ML) and Deep Learning (DL). AI in terms of functionality is nothing but a group of computer programs (which constitutes an algorithm) and techniques that are designed to perform specific tasks in order to mimic the human behavior. With AI, it is possible to solve mundane problems that humans tend to do with a lot of difficulty. At the same time, AI is being trained to perform tasks which the humans can do instinctively. AI works on machine reasoning principles like inference, planning, heuristics, etc. that helps in solving learning problems. Machine Learning is all about solving real world problems with respect to pattern recognition and learning from previous or existing data. Convolution Neural Network (CNN) is a part of Deep Learning technique particularly built to deal with tasks involving video and image data. CNN

performs various operations like convolution, computation, classification and feature extraction. Here CNN takes input in the form of an image where different filters are used to extract various features at the pixel level. Since CNN contains various layers each and every layer extracts some features like shape, structure, size, etc. These extracted features play a vital role in classifying an image. Similarly, in case of fruit detection, CNN can be used to extract the features like shape and texture to classify and identify the fruit along with the color to establish the ripeness level. Also, it can be automated to do so with help of appropriate technologies. With such automated fruit recognition and classification system, we can establish a means to diminish the human intervention for fruit classification in various areas like supermarkets, Agricultural fields, and even food industries.

## II. LITERATURE SURVEY:

[1]: In this paper, they have considered the visual features and classifiers which affects the most in identifying a fruit. As per this paper, common attributes considered for fruit classification are shape, size, color, texture, volume, etc. The proposed methodology involves the following techniques: Multi-class SVM, KNN, Naïve NB, DT, LDA, and BPNN.

[2]: This paper talks about automatically detecting and counting fruits in images containing dense and multiple pepper plants where they seem to be overlapping each other. Here they have explained an innovative technique for the purpose of identification. Also, they proposed a method for counting green colored peppers (raw peppers) in an environment where there is unwanted canopy as well as peppers seem to be overlapping each other, with the help of a two step process. At first, using a single image the fruits are detected and localized. In the preceding step many angles of single cluster is considered and

# Low-Cost Ventilators for Emergency

Shamitha Bijoor

*Electronics and Communication  
Engineering  
K S Institute of Technology  
Bangalore, India  
Shamithabijoor90@gmail.com*

Sinchana M N

*Electronics and Communication  
Engineering  
K S Institute of Technology  
Bangalore, India  
Ssinche2000@gmail.com*

Sushmitha S

*Electronics and Communication  
Engineering  
K S Institute of Technology  
Bangalore, India  
Ssushmitha954@gmail.com*

Theerthana S R

*Electronics and Communication  
Engineering  
K S Institute of Technology  
Bangalore, India  
theerthanaramesh5922@gmail.com*

Surekha Borra

*Electronics and Communication  
Engineering  
K S Institute of Technology  
Bangalore, India  
Surekhaborra@ksit.edu.in*

**Abstract**— The corona virus is a dangerous disease caused by SARS-CoV-2 virus which affects the respiratory system of human being, due to which the affected person requires artificial breathing which is given by ventilators. The main objective of this paper is to provide a simple, easy-to-build, easy-to-handle, low cost, portable ventilator. This system is based on Arduino UNO which controls pulse oximeter sensor, potentiometer and servomotor. This design also consists of an alerting system for emergency which involves GSM module, buzzer, and an LED. Oxygen count is taken from the sensor and according to the count the breath cycles are changed using potentiometer, the Ambu bag is compressed using servo motor. In case of emergency a message is sent to doctor using GSM.

**Keywords**— Coronavirus, ventilators, AMBU bag, respiratory system, Breath cycles

## I. INTRODUCTION

The corona virus disease which is very dangerous, created lot of disaster in the world since 2019. This was first recognized in Wuhan, China, in 2019 December. The cause for this disease is SARS-CoV-2 virus [15]. It is a highly infectious disease which spreads through affected persons contact such as sneeze cough or breathe. This mainly targets on human's respiratory system. The coronavirus has the potential to infect either the lower or upper respiratory tract. It passes through your lungs. It is possible for the lining to become swollen and inflamed. The virus can spread all the way to the bottom to your alveoli in some conditions. Mechanical ventilators are required if a patient has respiratory failure [9]. Throughout the world 53.1 Cr people were affected with COVID-19 and the death rate was 63L, in India 4.32Cr people were affected and 5.25L deaths were recorded. In a country like India where population is about 138Cr, it is a challenging task to provide ventilation for affected people. There was huge

crisis for mechanical ventilators during COVID-19. Despite the fact that India's medical field is one of the world's fastest growing, limited availability remains a key worry for the country's massive population. Aside from accessibility, cost is a significant obstacle to resolving medical conditions, as well as in terms of quick and high-quality care. The diaphragm contract and slides downward during inhalation. The lungs can expand due to the additional room in the chest. Rib muscles also aid in the expansion of the chest cavity by moving the chest wall upwards and downwards. Air enters the lungs through into the mouth and nose after they have expanded. Allowing the person to breathe, air passes into the lungs through trachea. In intensive care units, ventilators, also known as life support equipment, are used to help patients who are unable to breathe on their own. Before exhalation, carbon dioxide and oxygen are exchanged. The relaxation of the diaphragm causes the lungs to recoil, and the flow of air as a person exhale.

## II. LITERATURE SURVEY

Marjanovic et al. [1] have discussed about the transportation issues of ventilators and ways to overcome them. Mechanical ventilation is a crucial component of emergency treatment and is widely utilized in transportation. Human mistakes in ventilators are common and have been linked to increased morbidity and death. The purpose of the research was to provide a full ergonomic assessment of emergency and transportation ventilators, which included relative and absolute control system assessments and also individual's mental burden. We performed a comparative laboratory ergonomic assessment of 13 emergencies and transport ventilators using standardized settings and a global scientific approach. The experiment took place in a lab dedicated to respiratory treatment, with 12 medical physicians who've

# Machine Learning Based Blister Pack Fault Monitoring System

Sushma A V  
Department of ECE  
K S Institute of Technology  
Bangalore, India  
sushmaav610@gmail.com

Varshini B M  
Department of ECE  
K S Institute of Technology  
Bangalore, India  
varshinibm14@gmail.com

Gokul G  
Department of ECE  
K S Institute of Technology  
Bangalore, India  
gokultron18@gmail.com

Surekha Borra  
Department of ECE  
K S Institute of Technology  
Bangalore, India  
borrasurekha@gmail.com

Vishal Madhusudan  
Department of ECE  
K S Institute of Technology  
Bangalore, India  
vishalmadhusudan123@gmail.com

**Abstract**— It is very crucial to make sure that the tablets that reach the customers end has to be of a very good quality. Quality monitoring of these tablets has been automated to reduce the manual inspection task. Image processing technique has been implemented widely in these automated systems, but yet not efficient enough to meet high accuracy. In this paper, different Machine learning techniques are tested for their performance and the best classifier is employed for training in MATLAB platform. The classifier output is further integrated with Arduino based sensor control and rejection mechanism system, to identify and isolate and reject the defective tablet strips.

**Keywords**—Image processing, Quality Monitoring, Machine Learning, MATLAB

## I. INTRODUCTION

Modern living has given us a comfortable lifestyle while also separating us from nature. The products we use contains a variety of impurities that have resulted in illnesses and disorders. Consequently, people have started taking allopathic medicine, which provides immediate relief from ailments. Hence, tablets play an important role in the life of a person, and it is very necessary for the tablets to reach the customer's end safely with no defects. If the tablet packs are already defective after production with defects such as missing tablet, broken tablet, dimension mismatch, color difference, etc. in a tablet pack, then they should be identified and discarded before reaching the consumer's end. The inspection can be done either manually or automatically. Manual inspection is time consuming and requires many laborers which can also lead to inaccuracy in the result. Whereas the inspection performed automatically gives better results with more accuracy and consumes very less time. In industrial production and in terms of competitiveness, automatic inspection is critical. It is not a big deal for large scale industries to achieve this with the evolving technology of automated equipment that do the job of a human accurately and reliably, but it is expensive for small-scale industries that still rely on laborer to manually distinguish defective tablet packs from those that are not. When compared to automated devices, it is a difficult challenge for humans to accomplish this job efficiently. To overcome this

disadvantage, it is necessary to build a low-cost system that replaces manual separation with a device that is both dependable and portable.

This paper proposes a technique to automatically inspect tablet packets for flaws is with a camera-based inspection system. This system takes an image, processes it, and analyses it to produce a numeric value that can be used to make decisions such as rejecting defective tablets and keeping the non-defective tablets. The main hardware used in the system is a camera, conveyor belt, rejection arm and a microcontroller – Arduino UNO. The tablet packs are moved from one end to the other using a conveyor belt. The camera, which is utilized to capture the tablet image, is the most significant component of the inspection system. The faulty tablets are separated using the rejection arm. The controller is used to control the entire system using the program that has been written. The whole process is performed in real time situation.

The paper is organized as follows. Section 2 reviews the literature relevant to the work. Section 3 proposes a machine learning based tablet pack fault monitoring system. Section 4 presents the results and discusses systems performance. And Section 5 concludes the paper.

## II. RELATED WORK

Durga Karthik et al. [1] used Image Processing techniques to identify damaged tablets after manufacturing so that the defective tablet packs can be discarded before packaging and sending it to the consumer's end. Canny Edge Detection and Histogram are used to automatically determine the threshold values of image in different regions. An Edge image is created with the use of Canny Edge Detector and the characteristics of the images are stored. The test image is obtained and compared with the template image by measuring the Euclidean distance. Finally, if there is a defect detected between the two images an alert sent using MATLAB software. For a test image which had no defects, a similarity of 100 was observed, which decreased to 98.835 after a broken tablet, 41 with a missing tablet, and 0.34 with an empty pack. Image processing techniques along with the Euclidean distance metric have shown to be extremely useful in finding

# Alcohol Detection and Road Accident System

Sathvik U M  
Electronics and Communication  
Engineering  
K S Institute of Technology  
Bengaluru, India  
satvikum13@gmail.com

Sabarish I J  
Electronics and Communication  
Engineering  
K S Institute of Technology  
Bengaluru, India

Swagath Aithal P G  
Electronics and Communication  
Engineering  
K S Institute of Technology  
Bengaluru, India  
Swagath9632@gmail.com

Surekha Borra  
Electronics and Communication  
Engineering  
K S Institute of Technology  
Bengaluru, India  
Surekhaborra@ksit.edu.in

**Abstract**— In a country like India, where the population is increasing drastically there is improvement in the automotive industry and an increase in the total number of vehicles, which cause road accidents more frequently. The main objective of the project is to prevent accidents that are caused under the influence of alcohol and reach for help in time when an accident occurs. When alcohol is detected, the ignition of the car doesn't start which prevents drinking and driving. When an accident occurs, the GPS model sends the location of the accident and through the GSM model message is sent to close contacts, so that help is reached soon by emergency services. We can ensure safety of public and driver from this system.

**Keywords**—Arduino Mega, MQ-3 Sensor, Alcohol, Accident Detection.

## I INTRODUCTION

Road safety plays a major role in every country due to the rapid increase in accidents. In India deaths caused by road accidents are more comparatively. Road safety has become a main issue in the world. Drinking and driving is already a big issue in India. There are around 30% of road accidents happen around the world because of drinking and driving. It is unsafe even for the driver and the public. Drinking and driving is likely to emerge as one of the most significant problems in the near future. Even though there are many rules and regulations that are put up by the government, people don't follow them and risk their own lives. So, to prevent this we have made a system by which accidents can be reduced that are caused by drink and drive. In this system, we have implemented alcohol detection and accident detection systems. When a person under the influence of alcohol tries to drive a car, it detects the presence of alcohol through their breath. If the alcohol content is above the blood alcohol content which is 0.03% per 100ml of blood, then this system won't allow the car ignition to start. This work is done by the alcohol detection system. Nowadays, when an accident occurs we are not in a position to provide immediate treatment due to improper facilities. These problems can be resolved by

alerting emergency services or close contacts when an accident occurs. With the use of GPS and GSM systems, location coordinates of the accident can be shared immediately so that help can be reached soon by emergency services with no difficulties. From this, the rate of accident fatalities can be reduced drastically. We can ensure the safety of public and driver from this system.

## II. LITERATURE SURVEY

Ashok Kumar et al. [1] has designed a system for accident detection. The system helps in the prevention of accidents through alcohol detection and an eye blink system. When there is a presence of alcohol or the person is feeling drowsy, the alarm turns on. The components used in this system are Raspberry pi, alcohol sensor, eye blink sensor, buzzer, and vibration sensor. Even a webcam is used to capture real-time images in case an accident occurs. Here raspberry pi is used as the main processor for all the functions. An alcohol sensor is used to detect the content of alcohol. when it detects the buzzer starts buzzing at high volume. Eye blink sensor is used for preventing drowsiness while driving. A vibration sensor is used for detecting accidents. When an accident occurs, the vibration sensor detects it and sends messages to emergency contacts. Here, the implementation of the accident detection method is done using IoT. DawKhaingZar et al. [2] has designed an alcohol detection and road accident system. In this design, the main components used are microcontroller PIC18F452, Alcohol sensor, vibration sensor, GPS module, GSM model, DC motor, and LCD. The operation of this is mainly done by the microcontroller. The alcohol sensor senses the presence of alcohol in the air and then sends the signal. The vibration sensor is used for detecting accidents by sensing vibration that has occurred to the vehicle. GPS model sends the location of the accident, GSM module is used to send SMS



# Dual Axis Solar Traker Using Aurdino

Sahana S  
Department of ECE  
KSIT Institute of Technology  
Bangalore, India  
Sahanagowda391@gmail.com

Manu Kandra  
Department of ECE  
KSIT Institute of Technology  
Bangalore, India  
kandramanu@gmail.com

Chandana L  
Department of ECE  
KSIT Institute of Technology  
Bangalore, India  
Chandanalokesh2001@gmail.com

Dr Sudarshan B  
Department Of ECE  
KSIT Institute of Technology  
Bangalore, India  
sudarshan.bellary@gmail.com

**Abstract**—The current global energy crisis has resulted in a massive increase in the price of combustible energy sources. Solar energy plays vital role, in which it is used to capture the maximum power from the sunlight. The three key characteristics that affect the conversion of solar energy are the quality, quantity, and temporal availability of solar radiations. Hence to increase the efficiency of solar tracker we have come up with dual axis solar tracker, which tracks the sun accordingly to its position and results in generation of maximum energy. Light sensors are used to detect the existence of sunlight and servo motors to move the solar panel freely on the angle detected. The output power of the dual axis solar tracker was compared to that of a static solar tracker and a single axis sun tracker, and it was discovered that the output power of the dual axis solar tracker was maximized. Based on the results of the experiments, the developed system was shown to be successful in boosting the solar panel's performance.

**Keywords**— solar energy, dual axis, solar tracking, Arduino, solar panels, servo motors, LDR's.

## I. INTRODUCTION

In present world, solar energy systems including Photovoltaic and solar concentrating systems have been considered as the most applicable solution in terms of industrial and domestic appliances. Since sun movement is from east to west in a day, the solar panel tracks the sunlight accordingly to the sun direction. The sun's position in the sky is plotted using azimuth and zenith angles. Azimuth angle is with respect to sun direction over a daytime. Zenith is the angle of the sun looking up from horizontal or ground level. Single axis solar tracker is with respect to the day motion of the sun. As a result, the dual axis solar tracker was created to measure both day and yearly sun path movements (azimuth angle, owing to season). As a result, when the tilt angle of the solar panel is coordinated with the yearly variations in the sun's height, the solar panel's efficiency is maximized. While travelling east-west, the sun tilts at an angle of 23.5 degrees due to its yearly motion. So, to generate maximum power gain, dual axis sun tracker is developed in which LDR is used as light sensors. We have used Arduino board to implement this project and reason behind choosing it is due to low cost, same was implemented using

microcontroller too. By rotating the display in both horizontal and vertical directions, this tracker can more efficiently and effectively track solar rays. This project is mainly implemented to get maximum power gain compared to stationary and single axis sun tracker. This method is proposed which is eco-friendly, more reliable and user friendly too.

The following is a list of the primary contributions of the proposed paper:

- To track more solar energy, regardless of location or time of day, in order to improve efficiency.
- Create a dual-axis solar tracker based on Arduino.
- A comparison of a single axis solar tracker with a stationary solar panel.

## II. LITERATURE SURVEY

The energy efficiency of stationary solar panels ranges from 11 to 15%. A lot of study has gone into photovoltaic tracking systems. However, because the area is so large, there is always room for new ideas and advancements. One of the main reasons for the creation and production of photovoltaic tracking systems is the poor efficiency of solar modules and, as a result, the decreasing output of electrical energy. PV tracking systems, concentrating mirror PV systems (CPV), and photovoltaic/thermal hybrid systems (PV/T) are all examples of solutions that increase the output of ordinary PV systems. [1] It generates more power than fixed solar panels and has a 20 percent efficiency. [2]

During the rainy season, this system is operational. A sun-oriented tracker is designed to use the new standard of small sun-powered cells as shifting toward oneself light sensors, providing a changeable indication of their relative position to the sun by detecting their voltage yield. The solar tracker can be victorious in maintaining a solar array at a perpendicular angle to the sun by employing this strategy. Rainfall sensors might be used in the future to keep the system running while it rains, increasing energy production [3].

The microcontroller collects data, which is then sent to the computer, which displays it. Solar panels must be positioned

# Live Human Detection Robot

Hemantha V  
Dept. of Electronics and  
Communication Engineering  
K S Institute of Technology  
Bangalore, India  
hemanthavishnu33@gmail.com

Karthik B P  
Dept. of Electronics and  
Communication Engineering  
K S Institute of Technology  
Bangalore, India  
karthikbp123@gmail.com

Krishnaprasad B  
Dept. of Electronics and  
Communication Engineering  
K S Institute of Technology  
Bangalore, India  
krishnaprasadb13@gmail.com

Sindhu G  
Dept. of Electronics and  
Communication Engineering  
K S Institute of Technology  
Bangalore, India  
23sindhusindhug@gmail.com

Sudarshan  
Dept. of Electronics and  
Communication Engineering  
K S Institute of Technology  
Bangalore, India  
sudarshan.bellary@gmail.com

*Abstract— In today's world, the strength of the military of a nation defines its position in geopolitical affairs. In such a scenario, making any progress in the field of the military can save lives and also increase the military strength in the sensitive conditions of warfare. Most defense organizations today have turned to taking the help of the robots to carry out the dangerous and risky missions undertaken by the soldiers. The technology today allows the use of integrated systems that include video screens, sensors, detectors, weapons, and cameras. The systems created uniquely for such purposes are called defense robots and are variable shapes and sizes depending on the specifics for which it was created. In this paper, a system is proposed that makes use of a wireless camera that tracks the enemy. The robot would be built on the concept of integrated systems which would essentially have a sensors, drivers, and controllers. The proposed model is what we call a Defense Robot that uses DTMF to update the data in receiver side. The system achieves to find and save human life in sensitive border areas and disaster affected area protect the humans.*

*Keywords—Robot, Remote controlled, Health Monitoring, IoT.*

## I. INTRODUCTION

At present most of the people of a rustic board cities. In Metropolitan cities are developing more faster, the population is increasing. population can make hazardous like natural or manmade disaster way more serious accidents. The complexity to rescue teams is additionally put to stake. Indeed, a disaster may destroy the critical and big infrastructures of a city which alters the effectiveness of the rescue teams greatly. Disaster sites is complex and unsafe to be reached for rescue and there are a good threat and risk linked to rescue workers and survivors trapped in such accidental sites. These disasters can interrupt economically and social balance of the society. whereas soul can make disasters include, industrial, transportation accidents, major fires accidents etc. Hence during this model only target a system named as "a live soul detector" which is able to working in disaster environments of manmade structures like collapsed buildings, war fields etc. It is often assisted for firemen, police, and disaster

agencies with appropriate reconnaissance, site evaluation, human detection etc.

## II. LITERATURE SURVEY

[1] In this paper titled, "Alive Human Detection Robot for rescue operation", The robot vehicle is controlled by Android app application. From the mobile device they will send commands to the raspberry Pi. In Robot they had mounted the camera to see live stream. they had used microwave radar sensor. From this application If any object come across the radar sensor or Any changes happens across the radar sensor it will automatically alerts the use. from its radius. Ultrasonic sensor will measure the distance from changes which has happened at that place and they had used temperature sensor. By checking the temperature of human body. they will get to know he is alive or not. In this paper titled, "Human Detection Robot for Disaster Management", They have made the project simple and economically less. This project is based on Arduino Uno ATMEGA 328P. The power supply is 9v. When human body presents around 30ft from the passive infrared sensor it will alerts the user by sending signal to the Arduino. Then buzzer will on and LED starts glowing. The LCD 16X2 displays the message "HUMAN TRACE DETECTION".

[2] This project is mainly based on AT89C51 microcontroller. It can be controlled by using remote or personal computer. In remote controller we can be controlled by automatic mode and manual mode. In manual mode it can perform the operation by using RS232 logic cable from this it can transmit the signal. In automatic mode it can does the operation automatically by RF signal. in receiver side there will be a robot. From the users commands it will trigger up. By using the Passive infra-red (PIR) sensor it can finds that human is situated in that place or else it cannot. They had taken some safety precautions that they had connected fire and Gas sensor also camera to navigate the direction.

[3] In this paper titled, "Human Detection Robot for Disaster Management", They have made the project simple

# Generation of power using piezoelectric sensors and building a smart shoe for human tracking.

Amulya. R  
ECE  
K S Institute Of Technology  
Bengaluru, India  
r.amulya.2001@gmail.com

Gayathri. R. Warriar  
ECE  
K S Institute Of Technology  
Bengaluru, India  
gayathrirwarriar@gmail.com

Jagruti. Pai  
ECE  
K S Institute Of Technology  
Bengaluru, India  
jagrutipai2001@gmail.com

Guided by: B. Sudarshan  
Professor Dept of ECE  
K S Institute Of Technology  
Bengaluru, India  
sudarshan.bellary@gmail.com

**Abstract**—Smart in technological aspects means that the system has a quick-witted intelligence. Being in this generation we are very familiar with smart gadgets such as smart TV, smartphones, smartwatches. So why not think of creating a smart shoe? We have to accept the fact that footwear is an essential and irreplaceable part for human beings. This project aims to develop a smart shoe that can be used for tracking human beings by their location. But the interesting part is the shoe itself generates the energy which is required to drive the system. The piezoelectric transducers are used to meet the requirements. The microcontroller is the brain for the entire system. The microcontroller is programmed to achieve specific tasks in this project.

**Keywords**— smart shoe, piezoelectric transducers, tracker.

## I. INTRODUCTION TO SMART SHOE SYSTEM.

The main objective of this project is to create an inexpensive smart shoe that will help us to track humans using their exact location data. Piezoelectricity is exhibited by a few types of materials which has the ability to generate electrical power when external physical parameters like pressure and forces are applied to them. This procedure involves the conversion of mechanical energy into electric energy.

This project involves the above property of the materials in order to provide electrical power to the tracking system. The energy is generated by the piezo crystals if a person is walking, running, which are placed on the sole of the shoe. The same energy is used to drive the microcontroller and other devices.

With the aid of a mobile application, this system will act as a human tracking system which gives us the exact location of the person wearing the smart shoe.

A number of GPS tracking devices are in the market, used for number of purposes. Most of them are only limited to GPS tracking used in everyday life. In this, we are mainly using smartphones which are cheaper, widely popular and user-friendly types of devices.

GPS is Global Positioning System is a worldwide radio-navigation system formed by satellites and their respective ground stations.

When a person with the smart shoes walks, he or she closes the piezoenergy to the road surface in the form of impact, vibration, and sound due to the transfer of weight to the ground through each step. This energy is then trapped and converted into usable form like electrical energy.

In short, the main objective of this project is to design a smart shoe system that generates its own power through walking and also has real-time tracking abilities.

## II. EASE OF USE

The above study offers a wide range of the functional system, using smart shoes to locate a person with the help of a smart mobile application. It can be used even in outdoor environments. It is a detachable shoe accessory which is fitted with a pressure sensors pad placed inside the shoe which results in more portability and more efficient results.

## III. LITERATURE SURVEY

GPS smart shoes is an actual product developed by GTX Corp company famous for their wearable smart devices. It is basically a product with technology that involves a GPS tracking system. This system allows users access to view the position of the smart shoe with the help of a mobile application.

The GTX system is basically a two-way tracking device used to track the wearer of the device by matching the longitudes of the coordinates of the person accordingly<sup>[1]</sup>. The system possesses the ability to identify the person and alert with a message with a secure mobile application. At present, there are a lot of portable devices working with numerous energy techniques<sup>[2]</sup>. One such energy harvesting technology can be the utilization of piezoelectric sensors that work on the generation and consumption of energy with the help of the piezoelectric effect<sup>[3][4]</sup>. This effect basically deals with the ability to generate electrical energy with the help of special property called the piezoelectricity of the material which is the ability to generate electricity by the means of mechanical stress applied to it. The idea of a GPS tracker has come up as it provides the excellent

# Electronic Shoes To Assist Visually Challenged

S Tushar harinath  
Dept of ECE  
K S I T  
Bangalore, India  
tusharharinath@gmail.com

Raghavendra K P  
Dept of ECE  
K S I T  
Bangalore, India  
kpraghavendra24@gmail.com

Raghu B T  
Dept of ECE  
K S I T  
Bangalore, India  
raghubt17@gmail.com

Purusotham V R  
Dept of ECE  
K S I T  
Bangalore, India  
purusotham1837@gmail.com

Sudarshan  
Dept of ECE  
K S I T  
Bangalore, India  
sudarshan.bellary@gmail.com

**Abstract**— Evolution of era has constantly been endeavored with making every day existence simple. With a quick acced existence everyone nowadays is harnessing the blessings of era besides a few elements of the society. One of them is the visually impaired who've to depend upon others for touring and different activities. This paper pursuits at supplying one such theoretical version which includes the modern-day technology to offer green and clever digital useful resource withinside the shoe to the blind. We have used ultrasonic variety finder circuit for detection. Bluetooth module which in conjunction with GPS era will offer voice help to favored place and in panic conditions will ship SMS alert to registered cell numbers via the android application. The fundamental goal of the machine is to offer a handy and smooth navigation useful resource for unsighted which enables in synthetic imaginative and prescient through supplying statistics approximately the environmental state of affairs of static and dynamic gadgets round them. (*Abstract*)

**Keywords**—ultrasonic sensor, water sensor, Renesas, microcontroller.

## I INTRODUCTION

Vision is one of the maximum essential senses. As maximum of the facts human beings receives from the surroundings is through sight. WHO pronounced that during august 2014, approximately 285 million human beings be afflicted by loss of vision. It is predicted worldwide: 39 million blind and 246 million have much less vision. Around 90% of the visually impaired stay in low-earnings conditions. 82% of human beings residing with blindness are round 50 and above. Globally, uncorrected refractive mistakes are the primary motive of slight and extreme visible impairment; cataract is the main motive of blindness in middle- and low-earnings countries. The variety of human beings visually impaired from infectious illnesses has decreased withinside the final two decades in line with worldwide

estimates work. 80% of the visible impairments may be averted or cured. The primary trouble which each blind individual faces is with reference to commutation and navigation in everyday life. The maximum primary gear for them are on foot cane and manual puppies and additionally on kindness of fellow commuters. The maximum generally used device continues to be the blind stick. It suffers from drawbacks like plenty of practice, variety of motion, much less reliability in phrases dynamic hurdles and additionally variety detection. We will try and regulate this cane with digital additives and sensors. The ever-developing generation and with current tendencies can assist in synthetic and correct navigation. People with visually impaired confronted maximum of the demanding situations withinside the surroundings. The lengthy Hoover Cane utilized by them isn't always benefits at the same time as on foot and travelling. Using clever footwear for visually impaired human beings want now no longer to be relying on others for mobility. The structures we've got designed encompass sensors for sensing the encircling surroundings for giving remarks to the blind individual. It is used as a protection tool in addition to navigation tool. The digital hardware might be constant in footwear for users. User will put on the shoe and tour anywhere, and connected sensor will experience barriers close to the footwear and signals to assist visually impaired human beings. Our version makes use of GPS generation in conjunction with Bluetooth module which then will provoke an android utility as a way to connect with Google maps for navigation. In addition, we've got used ultrasonic which assist in impediment detection and on hurdle popularity will ring the speaker for exclusive periods to signify exclusive distances. We want at imparting an cheaper and mild weight and correct version which allows in handy navigation for the blind. Distress mechanism will ship places of longitude and range to preregistered cellular numbers in conditions of panic.

## IoT Enabled Smart Charging Station For Electrical Vehicle

AKHILA V  
Department of ECE, KSIT  
akhilavmane@gmail.com

RAJATH S BHUSHAN  
Department of ECE, KSIT  
Visvesvaraya Technological  
University, Belgaum, India  
rajathsbhushan@gmail.com

RAGHOTHAM C G  
Department of ECE, KSIT  
Visvesvaraya Technological  
University, Belgaum, India  
raghotham056@gmail.com

SIRI RAVINATH  
Department of ECE, KSIT  
Visvesvaraya Technological  
University, Belgaum, India  
siriravinath24@gmail.com

Dr. B SUDARSHAN  
Department of ECE, KSIT  
Sudarshan.bellary@gmail.com

**Abstract**— The requirement for clean environment has promoted the development of green car technology such as electric vehicles which are cost effective too. The number of Electric Vehicles (EVs) on the roads are increasing so charging infrastructure is gaining an important role. There are several issues on the EV charging system and some of them are option for improving the operation and efficiency, understanding of the charging behaviors of existing EV users. Thus, in this paper, we have introduced RFID (radio frequency identification) technology which allows automatic identification of users. This technology uses electromagnetic waves to transmit and receive information of the users.

With an increased number of Electric Vehicles (EVs) on the road's, charging infrastructure is gaining an ever-more important role in simultaneously meeting the needs of the local distribution grid and of EV users. This paper proposes a mesh network RFID system for user identification and charging authorization as part of a smart charging infrastructure providing charge monitoring and control. The IOT-based mesh network RFID provides a cost-efficient solution to identify and authorize vehicles for charging. The proposed system would allow EV charging to be conducted effectively while observing grid constraints and meeting the needs of EV drivers.

**Keywords:** Energy internet, electric vehicles, energy transmission.

### INTRODUCTION

The concept of electric vehicles Energy Internet has been raised because of its advantages like saving traditional energy [1]. Electric vehicles equipped with batteries can store a lot of energy thus it can be used for energy storage [2]. The mobility of EVs makes energy in the network be transported from one place to another. The network mentioned above is what we call the EV Energy Internet which can reduce the consumption of energy transfer comparing to traditional Vehicle-to-grid [3]-[5]. As more and more traditional cars are to be replaced by electric vehicles, the energy stored in

electric vehicles will become so enormous that electric vehicle-based Energy Internet will

have enormous potential. The reason we use public transport instead of dedicated electric vehicles to directly transport battery power to the charging station is because the cost of dedicated electric vehicles and drivers is also high. This cost may exceed the profit brought by the energy Internet advantage, so the use of the associate editor coordinating the review of this manuscript and approving it for publication was Giacomo Vertical. existing public transportation lines can reduce a lot of costs, so it will bring about the problem of energy transfer. Over the past few years, Electric Vehicles (EV) have gained importance because of their appeal as a credible alternative to gas-powered vehicles. With electric vehicles (EVs) projected to become a major mode of transportation in the future, there has been much debate about their adoption, notably among legislators. EVs, on the other hand, require a charging station that allows them to "recharge" their batteries in the same way that gasoline-powered vehicles do. While EVs are pollution free, the electricity used to charge their batteries may be drawn from traditional power plants, decreasing their appeal as an environment-friendly mode of transport. Many countries currently use coal, oil and natural gas for its energy. Fossil fuels are non-renewable; they bring on finite resources that will become too expensive or too environmentally damaging to retrieve. Solar energy is never exhausted since it is constantly replenished. Solar energy is renewable energy and it is mostly called "clean energy" or "green power" because it doesn't pollute the air does not result in carbon emission. There has recently been a push to create solar-powered EV charging stations that generate clean electricity. Our paper is all about the charging station design, working and uses with the disadvantages of the system. Every station is composed of a plug that becomes attached to a vehicle, supplying it with electric power to charge the vehicles. Solar-powered EV charging stations present a great opportunity to greenify our transportation needs, making electric vehicles end-to-end environmentally positive. With the reduction in solar costs and improvements in solar efficiency

# Hydroponic Farming Model

REKHA N  
Dept. of Electronics and  
Communication Engineering  
K S Institute of Technology  
Bangalore, India  
rekhan@ksit.edu.in

NSV JASHWANTH  
Dept. of Electronics and  
Communication Engineering  
K S Institute of Technology  
Bangalore, India  
nsvjash@gmail.com

RASETTY SANDEEP  
Dept. of Electronics and  
Communication Engineering  
K S Institute of Technology  
Bangalore, India  
sanjusandeep137@gmail.com

THANUSH RS  
Dept. of Electronics and  
Communication Engineering  
K S Institute of Technology  
Bangalore, India  
thanus008@gmail.com

SHRIKANTH CK  
Dept. of Electronics and  
Communication Engineering  
K S Institute of Technology  
Bangalore, India  
Shrikanthck007@gmail.com

**Abstract**—This paper demonstrates hydroponic drip irrigation system with integrated multiple sensors like temperature & moisture sensors. This project is best suited for indoor drip irrigation technique. Arduino technology is used here. The design is created can monitor important parameters in the hydroponic cultivation system such as Room temperature & humidity. The prototype is designed using Arduino that connects directly with sensors. This therefore is easily to monitor, manage data, and setting online. The evaluated results show that the system can decide the results from multi-sensor grouping as the setting correctly

**Keywords:** Hydroponic, soil-less farming, nutrient rich water, perlite, Rockwool, clay pellets. Hydroponic Cultivation

## I. INTRODUCTION

To describe the base term of hydroponics, hydroponics is the practice of growing plants using only water, nutrients, and a growing medium. The word hydroponics comes from the roots "hydro", meaning water, and "ponos", meaning labor, this method of gardening which does not use soil. Hydroponics is the practice of growing plants using only water, nutrients, and a growing medium. The needs of supply chain of food grains and other farming products as an average with populations of all consumers could be compensated by hydroponics- growing agriculture output.

Various methods in hydroponics are

1. Aeroponics
2. Drip System
3. N.F.T-Nutrient Film technique
4. Ebb Flow
5. Water Culture
6. Wick Culture

## II. LITERATURE SURVEY

Optimization and Control of Hydroponics Indoor Farming System with Live Data Monitoring [1]: In this paper they have used ebb and flow technique of hydroponics. Ebb & Flow technique is also called as Flood & Drain method in which nutrients containing solution is flooded to the plants and later drained once the plants are immersed completely. This system is low cost and ebb & flow is abundant in nutrients for the plants but Removal of harvested plants and damaged plants can be somewhat problematic

A Hydroponic System For Indoor Plant Growth[2]: Continuous flow solution culture method is used which contains a solution that is constantly passing through the roots. These roots are not submerged in water. So, We can save a lot of time and there are low risks of faults to occur. But, if the flow of nutrient solution stops, the roots will dry out and become stressed quickly and Pump failure can

cause the death of crops in a few hours, particularly in hot weather.

Automatic Control Of Hydroponic Cultivation Using IoT[3]: Wi-Fi based IOT technology is used with multiple sensors like LDR, Temperature, pH and air flow sensors. IoT systems have proven to be efficient and more productive but the drawback is Internet connectivity issues might occur and it is not cost efficient.

Indoor Garden Development using Hydroponic Agricultural Farming and Automation[4]: PIC 16F877A microcontroller is used which is designed using RISC (reduced instruction set computer) architecture which is easy to program. Due to the architecture having a set of instructions, this allows high level language

# Crowd Management Framework for Departure Control in Bus Transport Service using Image Processing

Mrs Rekha N  
Dept. of Electronics and  
Communication Engineering  
K S Institute of Technology  
Bangalore, India  
rekhan@ksit.edu.in

K Rishika Ravi  
Dept. of Electronics and  
Communication Engineering  
K S Institute of Technology  
Bangalore, India  
kukutllarishi126@gmail.com

Adithi S  
Dept. of Electronics and  
Communication Engineering  
K S Institute of Technology  
Bangalore, India  
adithisrinath7@gmail.com

Mahanth Sai M  
Dept. of Electronics and  
Communication Engineering  
K S Institute of Technology  
Bangalore, India  
mahanthasai@gmail.com

Dhrithirhuth Rajanna  
Dept. of Electronics and  
Communication Engineering  
K S Institute of Technology  
Bangalore, India  
dhruthirhuth16@gmail.com

**Abstract**—Crowd detection is an important aspect of video surveillance. Video surveillance systems are one of the most modern methods for estimating the density of people in a given area for providing facilities and obtaining human statistics. Factors such as severe occlusions, scene perspective distortions in real time application make this task a bit more challenging. Image recognition and classification using Convolution Neural Networks (CNN) are the two popular approaches used in object recognition systems. CNN models are built to evaluate its performance on image recognition and detection datasets. This paper develops a prototype of an intelligent public bus management system based on collecting data from surveillance cameras, processing image frames to estimate crowd density, and sending messages to bus depot as needed. Besides image processing algorithms, model consists of camera, software and WIFI for wireless data transmission at the Bus Depot. This system prevents the overcrowding of passengers, provide security, report passenger density data and thereby organize an effective bus management.

**Keywords:** Crowd Estimation, Video Surveillance, Convolution Neural Network (CNN), Occlusions.

## I. INTRODUCTION

In recent years, with the rapid development of technologies such as sensing, communication and management, improving the efficiency of traditional transportation systems through advanced technological applications is becoming more feasible. Therefore, intelligent transportation systems have gradually become a focus of transportation development around the world. Currently, many related applications exist in the field of bus information services for example, bus depots can utilize a dynamic information web page or a mobile app to inquire about the numbers of people waiting in the bus stops and send busses accordingly. If more comprehensive information is provided on existing bus information platforms, the quality of public transport services will be significantly improved. Thus, the number of passengers

willing to use public transport will increase. Through intelligent traffic monitoring, bus depot managers can preview the allotment of buses to a particular bus stop in real time and then make a decision based on the additional information and evaluate the waiting time. Furthermore, the bus depots can manage vehicle scheduling based on this information thus, operational costs depending on whether service quality is degraded or not are reduced effectively.

## II. LITERATURE SURVEY

People count system using multi-sensing application [1]: In this paper people count system has been developed using multi-element infrared sensor which is constructed using PbTiO<sub>3</sub> ceramics to set up a non-blocking and non-contact automatic real-time system which gives high accuracy. A pyroelectric array detector using human sensor information is employed to set out people count system for detection of passers and direction in which the people move in a 200cm wide door. A highly sensitive infrared array detector was fabricated using bulk ceramics. This system gives an accuracy of 95%.

Device-free human detection using WiFi signals [2]: Wireless sensing represented by WiFi channel state information (CSI) enables various fields of applications such as person identification, human activity recognition, occupancy detection, localization and crowd estimation. The proposed system consists of three steps pre-processing, feature extraction and decision making. First, the CSI data is preprocessed using band pass filter and the band is preserved to human breathing frequency. Second, prediction is done using two features that is average of subcarriers and missing numbers over subcarriers. Lastly, a decision tree is built to find human presence and absence. In this method an AP with two antennas is used as transmitters and a laptop is used as a receiver. This system gives an accuracy of 64.3%.

# Solar Inverter and Power Consumption of a Moving Vehicle

VANDANA S  
Dept. of ECE  
K S I T  
Bangalore, India  
Vandanasudhakar11@g  
mail.com

MADALA VIVEK  
KUMAR  
Dept. of ECE  
K S I T  
Bangalore, India  
madalavivekkumar@gma  
il.com

SNEHA N  
Dept. of ECE  
K S I T  
Bangalore, India  
Snehanurayanaswamy30  
62000@gmail.com

REKHA N  
Dept. of ECE  
K S I T  
Bangalore, India  
rekhan@ksit.edu.in

**Abstract**—Electronic vehicles have now embarked on a global trip and are steadily increasing in number. Electric vehicles' assets and service benefits have also proven useful in lowering travel costs by replacing petrol with energy, which is significantly less expensive. However, through a unique inventive approach, we have developed an electric car charging system that solves the long charging time, the lack of power stations for charging in off-city and remote places. This electric vehicle charging system eliminates the need to stop for charging because it charges the vehicle while it is in motion, and it is powered by solar energy.

**Keywords**—Solar energy, voltage sensor, dc motor, power grid

## I. INTRODUCTION

The technology used to charge a car while it is travelling is combined in a solar vehicle. The amount of energy input into this solar car was limited due to the vehicle's design. The photovoltaic cell converts sunlight into electric energy in solar cars. Before it can be utilised as a grid, the PV (Photovoltaic) converter converts direct current generated by solar panels into alternating current. Solar inverters are required for both central and distributed power installations to connect to the electric grid. According to grid powers, integrating solar power into the grid will have a negative influence on the electric system's robustness and reliability. This study was carried out due to the unsustainable use of fossil fuels, which are now limited resources and gradually running out depending on the rate at which we use them. At the present rate at which oil and gas is being consumed, it is presumed that known world reserves will run out of oil and gas in a little year from now onwards. The solar collector, which is made up of PV modules, collects solar energy, as we all know. Radiation is converted to electricity by photovoltaic cells by their very nature. Although this phenomena has been known for more than half a century, the levels of were only useful for evaluating radiation intensity until recently. An electric vehicle is a car powered by one or more electronic motors and propelled by electrical energy stored in batteries or other energy storage devices. When compared to conventional internal combustion engine automobiles, electric vehicles offer several

advantages, including a significant reduction in local air pollution due to the absence of a tailpipe, which means they do not emit harmful tailpipe pollutants from the onboard source of power at the point of operation. Depending on the fuel and technology used to generate power to charge the batteries; and reduced reliance on foreign oil, which poses a risk of vulnerability to oil price volatility and supply disruption for the United States and other growing economies.

## II. LITERATURE SURVEY

[1] has detailed the methodology employed in this work, which is a 10 kw solar-powered bidirectional electric car charger that charges electric vehicles from photovoltaic panels, ensuring a sustainable transportation future. The purpose of this article is to build a 10kw EV charger that can be fueled from both a PV array and the three phase AC grid, with the goal of achieving high power density and efficiency. [2] has discussed the methodology used in this paper, which is a solar charger for electric vehicles, in which a dc-dc boost converter is used to boost the solar panel voltage to station battery voltage and maximum power point tracking is used to optimise the solar panel output, and a complete simulation study of the system is carried out using Simulink of the MATLAB. [3] The On-board single phase integrated electric vehicle charger with V2G capabilities that reuses the traction inverter and motor is the subject of this study. The system is made up of an inverter and a dc motor, and it has a dual inverter drive train that produces high voltage charging when compared to conventional charging. It shows operation at 19.2kw with a 110-kw EV motor, with a measured efficiency of over 97 percent, demonstrating the viability of the integrated charger. [4] have discussed the methodology used in this paper is renewable energy based automatic recharging mechanism for full electric vehicles, the hybrid renewable resources, for example, wind generate and PV modules are used to produce power that automatically recharges electric vehicle storage systems, this paper presents an automated charging mechanism that automatically recharges the battery, thereby eliminating the



# Home Automation and Control Using Computer Vision

*SRINIVASAN M*  
 Dept. of Electronics &  
 Communication Engg  
 K S Institute of Technology  
 Bangalore, INDIA

*MOHITH KUMAR G*  
 Dept. of Electronics &  
 Communication Engg  
 K S Institute of Technology  
 Bangalore, INDIA

*REKHIA N*  
 Dept. of Electronics &  
 Communication Engg  
 K S Institute of Technology  
 Bangalore, INDIA

**Abstract**—Computer vision gives us the ability to detect and analyze human actions from images and videos. Artificial Intelligence combined with computer vision can be used to perform certain tasks based on the information detected from a video or an image. This paper introduces a home automation framework using computer vision and image processing. The work done will derive meaningful gestures of a person from a video and use it to control the home appliances. Based on the hand gesture detected, the corresponding appliance can be controlled or automated. The work done aims to develop a framework on which the appliances can be automated based on desired parameters by the user.

**Keywords**—component, formatting, style, styling, insert (key words)

## I. INTRODUCTION

Automation is the key to progress in any industry. The ability to control and automate the tasks will reduce the time and effort, helps us to focus on our primary objectives. One such automation is home automation. The controlling of home appliances can be automated according to our needs. Usually, the appliances are manually controlled by a switch. To automate the switching of appliances we have Bluetooth, Internet of Things, smartphone applications. Although all these methods are able to automate a home, we are trying to develop an alternative solution for the same. In our proposed work we are developing the system in such a way that anybody can control the home appliances hassle free by just using their hand gestures. We are developing an automation framework, upon which any appliance or any other feature can be added. Through computer vision we will be able to detect the hand gestures, upon detecting the hand gestures we need to process it, in order to get meaningful information from it. The corresponding appliance has to be controlled based on the gesture detected. There is an interface between computer vision and the microcontroller that controls the appliances. The information derived by the computer vision should be communicated to the microcontroller and then the appliances will be controlled by the microcontroller. This method provides an ecosystem inside a house such that anything can be automated as desired by the user.

## II. LITERATURE SURVEY

This paper uses segmented image processing to automate a home, a http server is used to transfer the data between devices and control it. Raspberry pi is used as the microprocessor to process all the data and receive it. To detect the wastage of electricity another circuit is used [1]. In this paper Artificial intelligence is used in the process of imaging through computer vision. It introduces the methods that can be used through computer vision in order to extract images from a webcam video and to process it for our requirements. This approach can be used to process the image using artificial intelligence. The calculation methods and approaches that are basically used to derive information were discussed [2]. Using the internet of things protocol the automation of home appliances was developed. The different scenarios are considered and analyzed. Based on the analyzed data the approaches for the automation of home were modified. The control of state of the appliances like bulbs, fans and other appliances were developed. The security aspect of the internet of things were taken care. The possible ways that can be implemented to improve the security level of the internet of things protocol and application layer [3]. This paper uses the methods to vary the brightness of the home light. Potentiometer is used to control the intensity of the light. Based on the analog value received from the potentiometer the values are mapped to a bulb. The Analog to digital converter is used to convert the potentiometer analog values to digital by a microcontroller. The potentiometer values are then converted to a range of 0 to 255 such that using pulse width modulation these values can be driven to a driver and in turn varying the intensity of light. The paper discussed on the different ways and approaches that can be used to reduce the electricity wastage [4]. This paper proposes a system that detects the activity of the human and can control the bulbs accordingly. This system uses Internet of things to solve this problem. The motion of the human is detected and that data is sent to a http server through the internet. The received data is then used to control the on off state of the bulb or any appliance. The mobile application developed can be used to control the automation of the appliances. This approach can be used in scenarios where the human motion has to be taken as a parameter to automate a device or control its state [5]. This paper discusses the hand gesture detection based on the parameters that corresponds to the shape of the hand. The location of each finger in a

# Arduino Based Smart Dustbin with Level Monitoring System and GSM

RANGASWAMY U

Dept. of ECE

KSIT

rangaswamy4835@gmail.com

TUSHAR R VASISTA

Dept. of ECE

KSIT

tusharvasista1929@gmail.com

S K BHARATESH

Dept. of ECE

KSIT

skbharatesh@gmail.com

SANTHOSH KUMAR BR

Asst. professor

Dept. of ECE

KSIT

santhoshkumarbr@ksit.edu.in

SHREYAS B ARADHYA

Dept. of ECE.

KSIT

shreyasaradhya015@gmail.com

**Abstract**—Things are becoming smarter as people become smarter. While the concept of smart cities is being discussed, there is a need for smart waste collection management. Smart is a concept. Smart buildings, colleges, hospitals, and buses have dustbins. As a result, the Smart Dustbin is considered an upgrade. a regular trash can by raising it to a smart

found in the region around poorly managed dust bins. The area near a dumpster is also conducive to higher levels of air pollution. Air pollution caused by a trashcan it can increase in the flies and mosquito it can causes life harmful diseases to the human beings and animals.

**Keywords**—Ultrasonic Sensor, GSM Module, Arduino UNO, LED's, Servo Motor, PIR Sensor etc....

## I. INTRODUCTION

As the world progresses, there is one obnoxious issue that needs to be addressed. In India 0.14 million tons of garbage are produced daily, and in the world 4.7 million tons garbage are generated. In our daily lives, we encounter images of rubbish containers that are overflowing and garbage spilling out. As a result, a high number of insects and mosquitoes and some bacteria on it, it causes the life-threatening diseases. Solid waste management is a major concern in urban areas especially in public places, where gathering of people will be more disposal of waste will be in equal amount. Not only in India but in most countries throughout the world as facing this problem. As a result, we came up with smart dustbin using Arduino and GSM with garbage level monitoring system, a solution that can reduce or at the very least decrease this problem must be developed. This helps us to backward, left and right. The level of dustbin is indicated by the ultrasonic sensor and the display is made of 16x2 LCD display and buzzer is implemented to indicate when it's full. The message is sent to the authorities by Wifi Module (Esp8266) [2]. The paper explains that we can implement smart dustbin not only by using Arduino we can implement it by using PIC Microcontroller. The microcontroller acts similar as the Arduino uno board. They have also used as IR Sensor to detect the object and a LCD display the level of the

trash can be implemented by using sensors and logics. Smart dustbins are a novel implementation concept. ultrasonic sensors are used to make a regular trashcan smart. Detecting garbage levels and giving a notification to the user GSM module is used to update the status of the bin. As soon as possible The Smart Solid Waste Collection System's trashcan is full. It's true. Garbage pouring out in and around is a regular sight. Disease-carrying insects such as mosquitoes, flies, bees, and driving ants can be maintain cleanliness in the cities. In INDIA smart city concept is still new, though it has gotten a lot of attention in now a days. when our current Prime Minister proposed the creation of 100 smart cities across the country. With the emergence of a significant number of smart cities, a large number of tasks must now be met. The most important aspect of a sensible lifestyle is cleanliness, and cleanliness begins with the trash can. Only if the dustbins are correctly positioned and collected the garbage properly, and that collected waste should be dumped in the suitable place. This implies that the society should be clean and well maintained.

## II. LITERATURE SURVEY

This paper mainly tells about how we can implement smart dustbin with monitoring system using LAN server and Arduino. They have mainly used the ultrasonic sensor to detect the level of dust present in the dustbin and report it to the authorities using LAN server. The server keeps on indicating the amount of garbage or dust present in every few seconds. Once the dustbin is full the authorities send the vehicle to collect the garbage [1]. Chinmay Kolhatkar explains in her paper the dustbin keeps moving in a path as soon it detects a person using a proximity sensor. The dustbin collects the waits for 30 seconds for the collection and then moves back in its path. The dustbin mainly moves around due to the motor driver which has the facility of moving forward

filling of dustbin. They have rain sensor to protect dustbin from rain and a gas sensor to detect harmful gases. GSM Modem to send message to the higher authorities [3]. The proposed model mainly made for the physically challenged person, for the smart dustbin to move on its own, it needs wheels so the person has inserted 2 dc motors for the movement of the dustbin and a L293D driver to drive it whichever the direction the user wants. The controls are mainly controlled by Bluetooth connected to the phone and Arduino. An ultrasonic sensor is used to detect the level and IR Sensors are used to detect a person. A gas sensor is

# The Orador Smart Community

Janhavi K P  
ECE  
K S Institute Of Technology  
Bengaluru, India  
janhavipgowda@gmail.com

Monisha B R  
ECE  
K S Institute Of Technology  
Bengaluru, India  
monishagangatakar879@gmail.com

Niharika S A  
ECE  
K S Institute Of Technology  
Bengaluru, India  
niharsuresh66@gmail.com

Shreya V Dev  
ECE  
K S Institute Of Technology  
Bengaluru, India  
shreyavasudev999@gmail.com

Santhosh Kumar B R  
Associate Professor Dept of ECE  
K S Institute Of Technology  
Bengaluru, India  
santhoshkumarbr@ksit.edu.in

**Abstract**— The ‘Orador’ is simply meaning ‘speakers’ in Spanish. Playing music in a large hall through multiple speakers leads to echoing, delay in the audio. In wired speakers, the delay is caused due to the increased length of the wire or cable. Whereas not many wireless speakers have multi room feature to play music in sync. Even if the wireless speakers are connected to a common network, it can form a small multi room speakers’ system to a small network, which should be located near to each other in order to play music. Placing them at different places may not be liable to play music due to network connectivity issues.

**Keywords**—wifi speakers, balena cloud, raspberry pi.

## I. INTRODUCTION

A Wi-Fi speaker connects wirelessly via home network with a smartphone or tablet. Whereas a Bluetooth speaker receives digital audio streams from the host device, which are typically compressed. It then decompresses, decodes and amplifies the audio through the built-in speakers. Balena cloud encompasses devices, server, and client-side software, all designed to get the code securely deployed to a fleet of devices. Once the device is set up with the balena OS, the code can be pushed to the balena build sever, where it will be packaged into containers and delivered to the fleet. All the devices and their running services can then be managed, monitored, and updated through the web dashboard. The raspberry pi 3 has 40 input-output pins that are used for serial communication for data, USB port and power over Ethernet which make the device useful in hard-to-reach places. In this project, we are integrating the advantages of both Wi-Fi and Bluetooth speakers into one model. Implementation of this project is not limited to just one device; it can connect up to 100 devices. The range of network is unlimited due to wide range of bandwidth of the Wi-Fi network and also depends on the strength of the Wi-Fi signal. It is a Multi room Audio Wi-Fi Speakers with master-slave technology. Any one of the speakers can be a

master, connected to multiple customized speakers with same Wi-Fi network. File streaming is feasible at both Master and Slaves, using the hardware Raspberry Pi and SD card internally. Balena is a complete set of tools for building, deploying, and managing fleets of connected devices. The tools are designed to work well together as a platform, but we can also pick and choose the components required for our project, and adapt them to our particular case.

## II. EASE OF USE

The above study offers a wide range of the functional system, using smart speakers which can be used as multi-room speaker. It can be used as normal speakers as well as Wi-Fi speaker. The range/quality depends on the strength of the Wi-Fi signal.

## III. LITERATURE SURVEY

- [1]Speakers history, tools, standards and implementation of Wi-Fi networks. However, the main purpose of this research paper is to understand the various problems associated with the implementation of these WLANs and propose recommendation and measures to solve these problems and mitigate potential risk factors.
- [2]Wireless explains the technology used for automotive Wireless Communication along with the various automotive applications relying on wireless communication. Automotive Wireless Communication gives drivers a sixth sense to know what’s going on around them to help avoid accidents and improve traffic flow. The paper also describes VANETS (vehicular adhoc networks) and real-world test network implementation. Finally, the paper is summarized.
- [3] Bluetooth is a modern wireless short-range RF technology that is designed to communicate wirelessly between various machines. The popularity of Bluetooth as a technology grows as time flies by and is still growing and

# Evidence Collection System in Car Using Embedded System

Dr. DEVIKA B  
Associate Professor ,ECE  
K S Institute of technology  
Bangalore,India  
devikab@ksit.edu.in

AISHWARYA BANDIGANI  
Electronics and communication  
engineering  
K S Institute of technology  
Bangalore,India  
aishwaryabandigani4@gmail.com

NIROSHA GJ  
Electronics and communication  
engineering  
K S Institute of technology  
Bangalore,India  
Niroshaniru750@gmail.com

NISHANTH J RAO  
Electronics and communication  
engineering  
K S Institute of technology  
Bangalore,India  
Nishanthjrao123@gmail.com

PAVAN KUMAR P  
Electronics and communication  
engineering  
K S Institute of technology  
Bangalore,India  
pavanskyrock@gmail.com

**ABSTRACT:** *The collection of information when the detection of collision round the vehicle Surroundings and analyse the collected information to possess the conclusion relating to the collision and at the same time it transmits the information over the wireless network. The Evidence Collection System, that is use to gather the information like speed, engine temperature, seat belt status , Alcohol content, GPS position, Date and time, images and video . This information help us to investigate the crime, and insurance claims. This information then transmitted to the insurance company and message will be sent to the Police station and Hospital about the Collision.*

**KEYWORDS:** *Evidence collection, microcontroller, GPS, Android application.*

## I. INTRODUCTION

The vehicle twist of fate is a chief public trouble in severa countries, in particular in India. This trouble remains including because of rider's bad geste comparable as pace riding, inebriated riding, driving with out enough sleep, etc. The figures of dying and incapacity are assuredly excessive due to overdue backing to folks who were given the twist of fate. These reasons big social and worthwhile burdens to humans involved. accordingly, numerous exploration organization and foremost motorbike producers have evolved protection bias to cowl riders from unintended injuries. still, correct protection tool for cars is sensitive to use and assuredly precious. Like Black Box of aeroplane, Car Black Box(called Event Data Archivist) is used to file data associated with injuries.

substantiation series device information riding facts, visible facts, collision facts and role facts after the

injuries in order that it could be used to dissect the twist of fate fluently and to settle severa controversies associated with car twist of fate comparable as crash action, coverage agreements. It may be used to now no longer simplest reconstruct what happed earlier than an twist of fate through Insurance Agents and police however ameliorate car layout, thruway layout and exigency clinical provider through automakers, authorities and sanitarium. The introductory features of a substantiation series device need to consist of visible recording. The introductory feature of the substantiation series device ready with wi-fi conversation device can shoot twist of fate role data to vital exigency and catastrophe garÃ§on in real- time facts. accordingly, motorists who need assist can admit provider snappily through police and sanitarium ambulance.

## II. LITERATURE SURVEY

In this paper, writer makes use of a prototype of Black Box For car opinion that may be mounted into any car. This prototype may be designed with minimum quantity of circuits. This can make a contribution to assemble more secure cars, perfecting the remedy for crash victims, assisting coverage agencies with their car crash examinations, and improving avenue fame so that you can drop the dying rate. ( 8) This paper affords a low fee gadget which gives end result to the being automobile manipulate troubles. This gadget has foremost precept elements videlicet Vehicle to Vehicle Collision Avoidance Unit(VVCAU) is used to keep away from crashing among cars and Black Box( BB) facts the relevant information about a car comparable as Engine Temperature, Distance from handicap, Speed of car, Brake fame, CO2 Content, Alcohol content, Accident

# FACE RECOGNITION USING OPEN CV

Shreyas Gowda  
*Dept. of Electronics &  
 Communication Engg*  
*K S Institute of  
 Technology*  
 Bangalore,  
 India  
 fastestappu9  
 0@gmail.co  
 m

RadhaKrishna L  
*Dept. of Electronics &  
 Communication Engg*  
*K S Institute of Technology*  
 Bangalore, India  
 radhakrishnarox@gm  
 ail.com

Shubham Kumar Singh A  
*Dept. of Electronics &  
 Communication Engg*  
*K S Institute of  
 Technology*  
 Bangalore, India  
 shubhamkumar.si  
 nghyaak@gmail.c  
 om

Devika B  
*Asst. Professor of ECE Dept.*  
*Dept. of Electronics &  
 Communication Engg*  
*K S Institute of Technology*  
 Bangalore, India

**Abstract:** In this research paper, we have proposed Face Recognition Door Lock System using OpenCV. Implementation of the project is for monitoring whether any anonymous person is trying to enter through the door. Through this project, we establish communication with machine using camera. For software coding python libraries are used. As soon as the person tries to walk through that door, the camera captures the image and the face detection is done. Then the face is verified with the registered faces that are available in the data base and is recognized. If the face is not recognized, an intruder alert will be sent to a registered mail id.

## I. INTRODUCTION

Nowadays in this new era of technology, our daily lives are based on smart technology. Many of the technologies are getting automated which means human's work is getting lesser day by day and are easily done using machines which saves human time. Examples of a few Automated technologies we use on a daily basis are Automated cars, Phone unlock using face/finger-print recognition, finger-print based bank accounts etc...

This paper proposes face recognition and door unlock using raspberry pi. It's important to know face detection and face recognition are two different things. In Face detection, only the face will be detected by the software. But in face recognition, the software not only detect the face but will also recognize the person. Everyone has different faces with unique characteristics. One cannot steal a person's identity. So, we use face recognition which is a highly secured process. Facial Recognition is a part of visual recognition. We humans use visual recognition all the time using our eyes, portrayed to our brain which defines it as meaningful concepts. But for a computer whether it's an image or a video, it's a matrix of pixels.

Human faces are usually very difficult to model as expressions keep changing, the lighting conditions may differ depending on the area and background, and humans might be wearing spectacles, sunglasses, masks etc... So, we can train the

machine with 3 or more images per person and train accordingly using OpenCV. OpenCV is a tool that helps the computer software to learn and understand the visual surroundings around us. The main objective of face recognition in our project is to find a same face as the input message from the set of images that are already being uploaded to the data base. If the person is unidentified by the camera, an intruder alert will be sent to the registered mail id. Doors can be unlocked without any human intervention.

## II. Literature Survey

Usage of the term "smart" in scientific means isn't new. As there in advancement in this technology, there is also a rapid improvement in home security automation. We explored various research papers which uses several different methods for Facial Recognition. From reference [1], we are using Fisher Face Algorithm to recognize the contrasts between the faces uploaded in the database. Fisher Face Algorithm implies with OpenCV, it acknowledges the applications for the facial recognition to run. With this Algorithm, class-specific transformation matrix is learnt such that the illumination is not captured just as in Eigen Faces. The input data plays an important role in the performance on the Fisher Face Algorithm.

We will be using Modern Recognition using Deep Learning so to pre-train a given model from the given the database of images such that it differentiates between various images present in it. Here, OpenCV, DLIB and Open Face are being used to differentiate between the various images using multiple set of algorithms. One main feature is that the HOG representation is being used to pattern the faces out of the images uploaded to the database. After this the facial landmarks are detected and then, perfectly centered. Finding the landmarks isn't the real problem here, it is telling faces apart. Encoding faces is a reliable method, where we use CNN and train it to generate 128 encodings for each face. Using these encoding and the assigned naming given to each image, we find the face from the input source.

Implementation of Multi-model Biometric verifications to develop more robust and accurate door locker access control using implemented sets of algorithms which extracts and classifies the features of the given database. This

# Automated precise billing system for shopping trolley

Shreyas C  
Dept of Electronics and  
Communication Engineering  
K S Institute of Technology  
Bangalore, Karnataka  
shreyaschida2k@gmail.com

Meghana Gowda V  
Dept of Electronics and  
Communication Engineering  
K S Institute of Technology  
Bangalore, Karnataka  
meghanagowda2000@gmail.com

Namith R.  
Dept of Electronics and  
Communication Engineering  
K S Institute of Technology  
Bangalore, Karnataka  
namith24303@gmail.com

Navya MS  
Dept of Electronics and  
Communication Engineering  
K S Institute of Technology  
Bangalore, Karnataka  
navyams30@gmail.com

Dr. Devika B  
Associate Prof  
ECE dept  
Dept of Electronics and  
Communication Engineering  
K S Institute of Technology  
Bangalore, Karnataka

**Abstract**— A supermarket can be a neighborhood where customers come to shop for his or her daily use. The foremost purpose of supermarkets is to produce availability of all the products and save the time of the patrons. But sometimes once they choose to pay their bill they wait in queue for an extended time, because scanning the products and total the bill and sometimes they get confused while comparing the complete price of all the products with the budget within the pocket before billing. To beat these problems, we've designed a wise trolley employing a Smartphone and Arduino. With this method, there's no need for the customer to square within the queue for the scanning of the merchandise items for billing purposes. This system provides on-spot scanning of the merchandise and shows its price details on LCD, Mobile applications as well as billing counters. Whenever a customer is completed with his/her shopping and near the billing counter, the data from the Arduino goes to transfer to the billing counter LCD Module then the customer through the Bluetooth module. during this way, it'll save the time of the customers likewise.

**Keywords**— *Arduino Mega, LCD, Mobile application, Bluetooth module*

## I. INTRODUCTION

In a Supermarket, Customers put their purchased items in the cart and once the shopping is finished, they have to face in the queue for a protracted time for billing the aim. It takes a long time for scanning each item that's implanted within the cart sometimes they get confused while comparing the complete price of all the products with the budget within the pocket before billing. This problem overcomes by this automated precise billing system. The barcode scanner application and cargo cell can tally the knowledge and transfer the information to the Arduino MEGA. It collects the data (List of purchased items) and transfers it to the mobile application, billing counter(software), and LCD. it'll display for both the billing counter further because the Customer's mobile

application. This automatic billing system implemented here can greatly reduce the queue at the billing counter and reduces the customer's shopping time.

## II. LITERATURE SURVEY

1. Modern embedded systems are typically based on microcontrollers, or CPUs, with integrated memory and peripheral interfaces. However, traditional microprocessors with external chips for memory and peripheral interface circuits are still widely used, especially in more complicated systems. In addition to improving supply chains and inventory, radio frequency identification (RFID) technology may also attract crowds of shoppers. IEEE 802.15 is the foundation of the ZigBee protocol. A mesh network, or a network without centralized control or a high-power transmitter/receiver capable of reaching all of the networked devices, is frequently created by ZigBee devices to transport data over greater distances by passing data through intermediate devices to reach more distant ones Using RFID and ZigBee connection, this study offers a centralized and automated invoicing system. Each item sold at shopping centers and big-box stores will have an RFID tag to indicate its category. Each shopping cart has a Product Identification Device (PID) built in, which includes an LCD, an RFID reader, an EEPROM, and a ZigBee module. In addition to being recorded in an attached EEPROM and transmitted to the central billing system via a ZigBee module, purchasing product information will be received using an RFID reader on the shopping cart. The central billing system obtains the EEPROM and cart data, accesses the product

# Temperature Controlled Exhaust Fan

Rajalakshmi.S

Dept. of ECE  
K S I T, Bangalore,  
rajhisribalakrishnan@gmail.com

Pokuri Mounika

Dept. of ECE  
K S I T, Bangalore  
pokurimounika7@gmail.com

Priyanka k

Dept. of ECE  
K S I T, Bangalore  
priyankakpriya3108@gmail.com

Devika B

Associate Professor  
Dept. of ECE  
K S I T, Bangalore  
devikab@ksit.edu.in

**Abstract:** A microcontroller based smart automated exhaust fan will be developed. If the environment temperature changes the exhaust fan automatically switches to work in required speed. It is a program that automatically opens. This can be used in electric appliances to reduce temperature it is a program that automatically opens. This can be used in electric appliances to reduce temperature.

**KEYWORDS:** Exhaust fan, microcontroller, temperature sensor, ADC0804, LCD

## I. INTRODUCTION

A temperature control exhaust fan is a system that automatically turns on the exhaust fan when the ambient temperature exceeds certain limits. In general, electronic devices generate more heat. Therefore, this temperature should be lowered to protect the device. Another option is to turn on the fan automatically. This article describes two circuits that automatically switch the fan when it detects that the temperature inside the device exceeds the maximum. This project is working towards the goal of converting analog to digital. The analog data of the LM35 temperature sensor is transmitted by the analog-to-digital converter ADC0804. The analog output of the temperature sensor changes by 10 mV in degrees Celsius. The ADC0804 is an 8-bit ADC. To obtain a reference voltage of 5V, find a solution of  $5V / 28 = 20mV$ . So this is a small change in analog value from ADCIC sensing. As the temperature changes, the ADC output is produced. The ADC digital output is equipped with a small controller to calculate temperature and fan control accordingly.

## II. Literature Survey

Usage of the term "smart" in scientific means isn't new. As there is advancement in this technology, there is also a rapid improvement in home security automation. We explored various research papers which uses several different methods for temperature controlled exhaust fan. There are some summaries of this publication in line with our proposed plan. According to those books we have included information about existing system. The existing system has a range of improve. And the existing system has some limitations. We have collected a lot of information on books and we have discussed here. Information compiled about automatic controls fan using various electrical component and so. We received more

information a specific publication about the human hearing device. We have collected information about our proposal a program from a specific and existing article published by the organization. To promote low cost, easy to use temperature controlled fan regulator which reduces the use of force and the assistance of such persons they can control the fan speed from their places.

## III. Methodology

The basic idea of this project is to determine the temperature, to indicate the temperature, and to change the temperature is seen as the difference in fan speed. Here the heat sensor used in the LM35 project and sensor output is provided from analog to digital converter. If the temperature is above 35C the fan must run at high speed. When the temperature drops below 15C the fan must be at a low speed. The fan speed should be adjusted according to the temperature range from 15C to 35C.

### 8051 Microcontroller:

The 8-bit microcontroller AT89C51 belongs to the 8051 family. Contains 128 bytes of RAM, 16-bit addresses, 16-bit timer / counter 2-6 interrupts ROM-4k bytes. The main function of the microcontroller in the proposed system is to analyze the temperature sensing temperature sensor. Based on the temperature, the microcontroller should adjust the speed of the storm.

### TEMPERATURE SENSOR:

The temperature sensor used in this project is LM35. The  $\sigma / p$  of this temperature sensor is approximately equal to the Celsius scale. This IC does not require external measurement to provide accuracy. The main function of the heat sensor in the proposed system is to determine the temperature of the fan surface outside.

### IV. WORKING:

First, you need to connect a 5V control voltage to the VCC pin (pin 20). Then connect the analog and digital pins (pins 8 and 10) to GND. To use the internal clock, connect a 10k $\Omega$  resistor between PIN4 and CLKR (PIN 19), then connect a 150pF cap between the four pins and GND to connect the oscillator's CS PIN circuit (PIN 1) must be connected. It is connected to GND to enable the ADC. To continuously read data from the ADC with a small controller, the RD PIN (PIN 2) must be connected to GND. In order for the ADC to continuously read analog data from the sensor, it needs to reduce the stylus (PIN 3) and PIN interference (PIN 5). The analog sensor output (LM35) is

# Anti-Theft Vehicle & Helmet Monitoring

Mrs.Ramya K R  
(Associate professor)  
Dept of ECE  
KSIT  
Bangalore ,India

Vinay K  
Dept of ECE  
KSIT  
Bangalore ,India

Vasanth Psi M  
Dept of ECE  
KSIT  
Bangalore ,India

Vishwas P  
Dept of ECE  
KSIT  
Bangalore ,India

Puneeth M  
Dept of ECE  
KSIT  
Bangalore ,India

**Abstract**—Accidents, as we all know, are growing more prevalent by the day. As a result, the government has adopted a series of laws and regulations in an attempt to prevent such blunders. Accidents are defined as an unanticipated event or a blunder that causes injury or, in the worst-case scenario, death. Two-wheelers have more accidents than other types of vehicles. Avoiding this by wearing a helmet and avoiding driving when inebriated are two options. This review looks at a variety of applicable measures, as well as smart helmets, for preventing accidents. This research also contributes to our knowledge of Internet of Things (IoT) technology, which is rising in popularity these days. The approach presented employing a microcontroller, an RF transmitter, and other sensors is cost effective, according to the literature study, however the system is not.

**Keywords**—Accidents, helmet monitoring and Regulation

## I. INTRODUCTION

Wearables, home automation, smart appliances, smart agriculture, and other sectors where equipment and people interact via a network are all examples of where the Internet of Things is now being applied. The goal of IoT devices is to collect data and send it to a server, where a large quantity of data may be generated. We can draw inferences from the data collected by processing and analysing it. This has the advantage of providing real-time data reporting from the environment. Motorcycle accidents are on the rise these days, and many people are dying as a result. Using a smart helmet can help you avoid this. According to the poll, four people die in India every hour because they do not wear a helmet. Over 48,746 two-wheeler riders perished in road accidents in 2017, with 78.3% of them without wearing a helmet. Before the bike starts, the smart helmet must analyse two important demands in order to go past or fix this. The first criterion is whether the rider is actually wearing the helmet instead than merely keeping it on. Second, sensors might be used to analyse the user's breath to determine whether or not he has ingested an alcoholic substance. Third, if a person is involved in an accident, the sensor evaluates the status of both the person and the bike.

## II. LITERATURE REVIEW

M U. [1] presented "Intelligent Accident Identification and Prevention System Using GPS and GSM Modem" by Priyanka Berade, Kranti Patil, Pradnya Tawate, and Prof. Ghewari. When the accident is detected, the PIC sends a signal to the GPS, which monitors the location and sends a signal to the GSM module, which sends a signal to the coded number. In comparison to other microcontrollers, the PIC microcontroller is exceptionally quick and straightforward to program me, according to our research

and this publication. We choose a PIC microcontroller because speed is critical in emergencies like car accidents. Following the identification of the accident, the position must be determined, and we will do so using GPS (Global Positioning System), a satellite navigation system.

"Smart Human Two wheeler Safety System" was proposed by Mr. K elaiyaraja, k.rajkumar, and m. sheikh Mohamed [2]. This leaflet depicts our goal of safe riding and adhering to traffic laws. Every year, a large number of people die in India as a result of traffic accidents, and two-wheeler drivers play a big role. Riders must wear safety gear, like as helmets, at all times. As a result, infrared sensors are used to detect the skin in front of the helmet in order to determine if the rider has equipped the helmet. An alcohol sensor is also present to determine whether or not the rider is inebriated. The PIC controller is attached to the sensors. The PIC micro controller is a low-cost, easy-to-reprogram micro controller that is also highly quick and dependable.

"An efficient vehicle accident detection utilising sensor technology," offered P.Kaliuga Lakshmi, C.Thangamani, Research scholar, Assistant Professor, P.K.R Arts College for Women, Gobichetti palayam[3]. It focuses on accident detection, which is one of our goals. The absence of automatic accident detection is addressed by this method.

"Microcontroller and Sensor Based Smart Biking System for Driver's Safety," suggested S. J. Swathi, Shubham Raj, and D. Devaraj [4]. The suggested technique for developing a safety system that is combined with a smart helmet and an intelligent bike to minimise the likelihood of two-wheeler accidents, bike theft, and drunk driving instances is described in this article. This gadget is designed to ensure the safety and security of both two-wheeler users and two-wheelers.

Ahyoung Lee et al[5]. proposed a system based on three sensors: an acceleration sensor, an ultrasonic sensor, and a carbon monoxide sensor, as well as an Arduino MCU (Micro Controller Unit) with a Bluetooth module, to add safety to the system.

## III. METHODOLOGY

The major emphasis of this technology for automated bike unlocking is face recognition. The web camera captures the person's image and saves it in the processor for comparison.

A webcam was used to capture this image. For picture processing and comparison, Open CV software is



# Patient Monitoring System Using IoT

Akshay Kumar D  
Dept. of Electronics &  
Communication Engg  
K S Institute of Technology  
Bangalore, INDIA

Nayan D  
Dept. of Electronics &  
Communication Engg  
K S Institute of Technology  
Bangalore, INDIA

Kashyap P  
Dept. of Electronics &  
Communication Engg  
K S Institute of Technology  
Bangalore, INDIA

Kruthik S  
Dept. of Electronics &  
Communication Engg  
K S Institute of Technology  
Bangalore, INDIA

Ramya K R  
Prof Dept. of Electronics &  
Communication Engg  
K S Institute of Technology  
Bangalore, INDIA

**Abstract**—Nowadays Health-care Environment has developed science and knowledge based on Wireless-Sensing Technology. Patients are facing a problematic situation of not anticipated demise due to the specific reason of heart problems and attack which is because of lack of technology in medical field and also basic treatments at the needed time. So, we are proposing a innovative project to elude the risk appetite while in critical stage, also which is capable of displaying temperature and health data in which data can stored on cloud platform and to alert ward incharge. All these can be accomplished by using sensor technology, where we make use of sensors and led display the read and display the data, node mcu which is basically a Wi-Fi protocol. Thus, Patient health monitoring system based on IoT uses internet to effectively monitor patient health and helps to communicate to the loved ones in case of any problems and save lives.

**Keywords**—IOT, node MCU

## I. INTRODUCTION

repetitive measurement of patients basic parameters such as heart rate and rhythm, respiratory rate, blood pressure, blood-oxygen saturation level, and many other parameters have become a common basic parameter that has to be considered as a major factors for critically sick patients. When accurate and immediate decision making is crucial for effective patient care, electronic monitors are frequently used to collect and display physiological data. Such type of data are stored using non-invasive sensors from less seriously sick patients in a hospital's medical-surgical units, labour and delivery suites, nursing homes, or patients own homes to detect unexpected life-threatening conditions or to record routine but required data efficiently. We usually think of a patient monitor as something that watches for and alerts against—serious or life-threatening events when patients are rigorously defined as “repeated or continuous observations or measurements of the patient, his or her physiological function, and the function of life support equipment. As of the case study made on internet we observe that increasingly growing number of people with chronic diseases, this is due to different risk factors such as dietary habits, physical inactivity, alcohol consumption, among others. According to World Health Organization (WHO), 4.9 million people die from lung cancer from the consumption of snuff, 2.6 million under the section of overweight, 4.4 million for Over or elevated cholesterol and 7.1 million subjected to high blood pressure. It is said that in the next 10 years, deaths would increase by 17% from chronic diseases which is approximately about 64 million people (Numbers are precise) -> Chronic diseases - are

highly variable in their symptoms as well as their evolution and treatment. Some if not monitored and treated as soon as possible they can end the patient's life. Among the most some of the common chronic diseases that can be treated and monitored are as follows: diabetes, blood pressure, low oxygen saturation level. Patients with these diseases besides having limitations in their physical condition, also often have economic, emotional and social relations problems, among others. Often Patients take more time to accept and adapt the reality of disease long term because disability. Reason whereby The group of people with these chronic diseases must have to be constantly monitored by your doctor to discuss the state of it and set the appropriate treatment. From long back the standard way of measuring glucose levels, blood pressure levels and pulse rate, was with traditional exams in a specialized health center. Thanks to advancement in technology out there today in which there is great variety of running sensor which is capable of reading vital signs such as blood pressure level, glucometer, heart rate monitor, including ECG which allow patients to take their major actions daily.

Although the main intentions of these readers is that patients know their major actions daily, And also the reason to be second on list of priorities is that when taken daily tests, and is to be stored on constant basis and results which avoids daily tests. Also doctors do recommend to make out workout routines that allow them to improve the quality of life and overcome such diseases

-> The internet of things applied to the care and monitoring of patients is increasingly common in the health

sector, in the objective to improve the quality of life of people.

The concept of Internet of things (IoT) is recent and is defined as the combination of all devices that are capable of connecting to the network, which can be controlled by the web servers and in turn provide information in real time, which enables interaction with people they use it especially doctors and ward in charge. Another concept of IoT "is the general idea of things, especially everyday objects, which are readable, recognizable, locatable, addressable and controllable via the Internet either through wireless LAN, wide area network, or by other means

IoT The term itself was first mentioned by Kevin Ashton in 1998 and aims at the exchange of information. On the other hand the Internet of things can be seen from three patterns or model, which are Internet oriented middleware, sensors

# Positioning of Dish Antenna using TV Remote

SAMIKSHA S

ECE

K S INSTITUTE OF TECHNOLOGY  
BANGALORE,INDIA  
samikshasrinivas03@gmail.com

YASHASWINI N

ECE

K S INSTITUTE OF TECHNOLOGY  
BANGALORE,INDIA  
yashaswini1122@gmail.com

RANJANA P

ECE

K S INSTITUTE OF TECHNOLOGY  
BANGALORE,INDIA  
ranjanapranju2000@gmail.com

SINDHU J

ECE

K S INSTITUTE OF TECHNOLOGY  
BANGALORE,INDIA

Dr .RAMYA

ASSISTANT PROFESSOR,ECE

K S INSTITUTE OF TECHNOLOGY  
BANGALORE,INDIA

**Abstract**— The paper relates to the positioning of dish antenna using an TV remote. We are using a microcontroller for processing commands related to the positioning of the dish. The dish is mainly used to receive signals coming from satellites, and the aim of the project is to adjust the dish position to get the maximum number of signals from satellites. We know that the manual process of adjusting the dish is very time-consuming and can also be incorrect, so to overcome these problems, we can use a remote to adjust the antenna. By implementing a system for controlling the angle of the dish, the system becomes more efficient and accurate.

**Keywords**—component, formatting, style, styling, insert (key words)

## I. INTRODUCTION

A dish positioning system is implemented, which can be controlled with the help of a TV remote to set the position. The purpose of the dish is to receive signals from broadcasting sources. In this project, a system for setting the position of the dish with a single TV remote was implemented. Two motors are used in the system for moving the dish in vertical and horizontal directions. The TV remote, which controls the dish, acts as a transmitter, and the information transmitted by the remote will be received by a receiver. The data transmission is direct from the remote to the microcontroller via the receiver. The micro controller, which is interlinked to the receiver, receives signals and then transmits control signals to the motors, which are employed for moving the dish.

## II. LITERATURE REVIEW

[1] In this paper titled, "Microcontroller Based Wireless 3D Position Control for Antenna," This system controls the movement of the dish antenna in all directions through an android application. The main disadvantage of this system is that we have to enter the angle of rotation.

[2] In this paper titled, "Wireless control system for dc motor to position a dish antenna using a microcomputer," its advantage is to position a small dish antenna at the desired azimuth and elevation angle, but it is very difficult to find the azimuth and elevation angle and also very time-consuming.

[3] In this paper titled, "Android based antenna positioning system," The abovementioned paper is about the positioning

of antennas using an Android. It achieves the possible position of the antenna by remote operation using wi-fi, and the main drawback of this paper is that the communication is done through a wi-fi router and it may be affected by weather conditions such as rainfall.

[4] In this paper titled, "Android based automatic sector antenna positioning using Atmega328p", this process mainly involves the use of cell phones to set the position of the antenna with the required angle in use. Comparatively, the cost and maintenance of this project is set to be very high.

[5] In this paper titled "Satellite dish positioning control by DC motor using IR remote control", Here, a peripheral interface microcontroller was used, which can be operated by using an IR remote. Instead of adjusting the dish manually, this paper helps in adjusting the position of the dish through an IR remote.

## III. OVERVIEW OF THE MODEL

As per the previous references, the following are the obtained inferences:

- The overall model is small and easy to build. The circuit has an IR sensor which controls the dish antenna.
- The rotation of the dish is controlled by the movement of the two motors which moves in clockwise and anticlockwise direction.
- Furthermore, the antenna even moves in horizontal and vertical directions. The TV remote and the input of the user is the main function of this positioning system.

The above-mentioned method that we have added to our methodology process is that if it get damaged we can repair it easily, and it is not waterproof. it can be easily carried anywhere and can be projected in different angles too.

# Review on Anti Sleep Glasses

Vignesh Muthaiah R  
dept of electronics communication  
engineering  
KS Institute of technology  
Bengaluru, India  
vigneshmuthaiah62@gmail.com

Vikas S  
dept. of electronics and communication  
engineering  
KS Institute of technology  
Bengaluru, India  
vikasgowda0311@gmail.com

Vinuth S Reddy  
dept of electronics and communication  
engineering  
KS Institute of Technology  
Bengaluru, India  
vinuthreddy12345@gmail.com

Vishal Sanjay Raju  
dept. of electronics and communication  
engineering  
KS Institute of technology  
Bengaluru, India  
vishalsanjayraju05@gmail.com

Vishalini Divakar  
Asst. Professor,ECE Department  
KS Institute of technology  
Bengaluru, India  
vishalnidivakar@gmail.com

**Abstract**— Drivers do sometimes fall asleep while driving, which is dangerous because it may cause fatal accidents or even death. Our project will try to prevent such consequences of an accident, we can use this gadget called sleepless glasses to alert the driver when he feels drowsiness. This system is based on IR sensor and Arduino mini which is very small and compact. This design also contains the buzzer which is used to alert the person while driving or working during night times. Whenever the person closes his/her eyes for 5 seconds the circuit will automatically detect and start giving the buzzer alert, when he opens his eyes after the alert it will stop giving the buzzer signal. The whole circuit is placed on a spectacle which can be wore at anytime and anywhere

**Keywords**—Drowsiness, CNN, Simulator, Sleep Detection.

## I. INTRODUCTION

In India majority of people spend 3 hours in a day driving. People drive very far distance to supply major commodities to all the cities in India. Due to this they suffer from sleep disorders, which results in sudden falling of asleep while driving. According to AIIMS Neurology's research more than 20% of all road accident victims are found suffering from sleep disorders and OSA (obstructive sleep apnea). So, by using modern technologies we can try to minimize the amount of road accidents occurring every year. Our project will try to detect whether the driver while driving is sleeping or not. Whenever the driver falls to sleep during driving the gadget will alert the driver by using buzzer. We have some techniques, such as psychological and automobile-based approaches, that will be able to detect the driver's drowsiness, since this technique will highly interrupt the driver's physical environment, the proposed system is primarily non-interrupting to measure the driver's drowsiness. When the buzzer is turned ON, the driver will automatically get alert and will wake up from sleep. The gadget will check whether the person is closing his eyes or not, based on that it will alert the driver. When the person closes his or her eyes for about 5 secs, the circuit will automatically detect that the person is sleeping and give alert. This can also be used not only during driving but also

for factory workers while working during night times, and even watchman who works during night.

## II. LITERATURE REVIEW

[1] In this paper titled, "Real-time Driver-Drowsiness," Detection system using facial features", object tracking an estimated targeted position in every frame of an image sequence, it also targets the previous frames. Basically, the facial recognition software collects information about the eyes, lips, eyebrows, and nose from the face Drowsiness detection can be subdivided into two types: with contact and without contact. With contact, there are certain objectives that can detect a driver's drowsiness. Without contact, we can detect a driver's drowsiness with some electronic gadgets like video recognition, which is able to collect information about the eye and head state of the driver.

[2] In this paper titled, "A Realistic Dataset and Baseline Temporal Model for Early Drowsiness Detection" Drowsiness detection can be identified using many techniques, and there are many types of handmade products or it can be found using CNN. Most detections are done using sensors or eye blinker detectors so that we can get the information for those methods. Real-life drowsiness detection has a large dataset of info about the cases that happened due to the carelessness of the driver while driving the vehicle. In the above experiment, they have conducted some kind of feedback review with 30 to 40 people sharing their experiences while driving for a long duration of more than 10 hours. They have collected more data about real-life drowsiness.

[3] In this paper titled, "Detection based on Respiratory Signals Analysis". The abovementioned paper is about the detection of drowsiness from respiratory organs. For this experiment, some people volunteered themselves. In order to find the accuracy of detection, they constructed an algorithm. They had to setup a driving

# Ultrasonic Walking Stick for Visually Impaired People

Ashritha. R.  
Dept. of ECE  
K S Institute of  
Technology  
Bangalore, Karnataka  
ashritha2001@gmail.com

Gayathri. P. K.  
Dept. of ECE  
K S Institute of  
Technology  
Bangalore, Karnataka  
gayathripl213@gmail.com

Vishalini Divakar  
Dept. of ECE  
K S Institute of  
Technology  
Bangalore, Karnataka  
vishalinividivakar@gmail.com

Dhanya Sukanth. B. K.  
Dept. of ECE  
K S Institute of  
Technology  
Bangalore, Karnataka  
dhanyasukanth007@gmail.com

Disha Shivani  
Dept. of ECE  
K S Institute of  
Technology  
Bangalore, Karnataka  
dishashivani2001@gmail.com

**Abstract**— Globally, at least 2.2 billion people are visually impaired. They find it challenging while crossing the road or reaching to their destination without assistance from another individual. The traditional cane does not help to detect the obstacles or the potholes in their path. It is outdated. Hence using technology, we have come up with a stick that uses various sensors like ultrasonic sensor, light and water sensor to make aware of their surroundings. We have used Arduino Uno to interface these sensors. RF module has also been used to help the individual find their stick if misplaced.

**Keywords**—Ultrasonic stick, sensors, Arduino Uno, stick, visually impaired.

## I. INTRODUCTION

Visually challenged people find it difficult to interact and sense their environment. Walking in public is very difficult for blind people, because it is tricky to distinguish obstacles appearing in front of them, and they have trouble moving from one place to another. They depend on their families and friends for going to places and visiting their favourite places. This holds them from taking part in any social activities. Researchers have spent several years to design an intelligent and smart stick to assist and alert visually impaired people from hindrance and give them information about their current location. Over the last few years, research has been conducted to design a good and reliable system for visually impaired people to sense danger while they walk on the street. Smart walking stick for the blind is particularly implemented to detect obstacles which helps the blind to navigate care-free. The main aim of this project is to provide a cheaper and affordable walking stick for the visually disabled people to detect the obstacles in various directions, detecting pits and potholes to make it safer for them to walk. This smart stick is designed for the visually challenged people for their easy navigation.

## II. LITERATURE SURVEY

Umme Kaswar Alam and team has developed a walking stick for the blind using an ultrasonic sensor for detecting obstacles and an GPS module and antenna for position detection.[1] Nairwita Dey and her team have implemented a walking stick for the visually impaired people. This stick has made it easier for them to navigate their path. They have used an ultrasonic sensor and implemented using PIC microcontroller 16F877A.[2] Dada Emmanuel Gbenga and his team have built an walking cane for the blind using ultrasonic sensors, Arduino ATmeg328 microcontroller and an buzzer. This walking stick helps to detect obstacles in his/her way, and a buzzer is alerted if any obstacle is found.[3] Vipul V Nahar and his team have designed an innovative stick for visually disabled people using an ultrasonic sensor, moisture sensor, microcontroller, and an RF module. This system allows obstacle detection as well as locating the stick if misplaced.[4] G.Savitha and her team have constructed a smart blind stick using Arduino and ultrasonic sensors. This stick detects the obstacle in front of the disabled person and gives response either through vibration or a command. [5]D. Chiranjevulu has designed a walking stick which helps the visually impaired people to navigate through easily. He has used Arduino, Ultrasonic sensor, LDR and a buzzer which sounds when an obstacle has been detected. The buzzer has been used as a voice module here. LDR helps in informing the person if he/she is in a light or dark environment. [6] Sularso Budilaksono has developed a prototype for a walking stick that is helpful for the blind people. HS-SF04 ultrasonic sensor has been used and it has been set to a range of 7 centimetres. A regulator has been used to reduce the DC voltage as well. All the components have been mounted on a PVC material of 0.5 inches. [7] G. Srinivas has built a walking stick that has the capability of detecting obstacles up to 400 centimetres range, in front of the user, from head to toe. It also consists of IR sensor which helps in detecting elevated or declining surfaces like stairs. This stick can also

# Attendance System Using Face Recognition And Contactless Thermal Screening

Sudheer B  
Dept of Electronics and  
Communication Engineering  
K S Institute of Technology  
Bangalore, Karnataka  
Sudheerbkumar123@gmail.com

S Manoj  
Dept of Electronics and  
Communication Engineering  
K S Institute of Technology  
Bangalore, Karnataka  
manojreeram2000@gmail.com

S Rahul  
Dept of Electronics and  
Communication Engineering  
K S Institute of Technology  
Bangalore, Karnataka  
rahul.charan2008@gmail.com

Vishalini Divakar  
Dept of Electronics and  
Communication Engineering  
K S Institute of Technology  
Bangalore, Karnataka  
vishalinidivakar@gmail.com

**Abstract**—Attendance is one of the most important barriers to assessing employee or student well-

being. In most of the educational institutions, attendees are marked by calling their names or registration numbers and marking those present in registers. But in this method of presence requires a lot of paperwork and is time consuming. To make this easier for different educational institutions, they use personal identification methods such as RFID, Bluetooth, biometrics, etc. Of all these techniques, face recognition is one of the most effective. It has many applications in attendance programs and security systems. In the current context of Covid, a hot test is a necessary procedure to be performed in all companies and educational institutions. In this way, the presence of marking is used to identify the face of the student or employee and the temperature test is also added to the attendance marking system. In this proposed system the camera captures images of the person who is comparing the image to the database and if it is the same as those present, they will be stored directly on any storage device at the appropriate person's name temperature and ID number. In this way, attendees can be automatically tagged and at the same time the system can scan each student or employee to identify potential Covid-19 patients and reduce the time spent on marking attendance and hot tests.

**Keywords**—Face Detection, Thermal screening, attendance, Database.

## I. INTRODUCTION

person and ID. In this way, attendees can be automatically tagged and at the same time the system can scan each student or and hot tests.

## II. LITERATURE SURVEY

In the Paper [1], the system has selected Raspberry pi 3 for face recognition. The Pi module is attached to the Pi camera. Facial identification enables the non-face-to-face separation of people to be seen. During this time, we will use to go and apply facial attention where the faces of all the students are seen during the session. The program provides features such as face detection, feature removal, output detection features, and student presence analysis. Accuracy increases in finding and detecting faces

Attendance is one of the most important barriers to assessing the familiarity and effectiveness of an employee or student. This shows the student's dedication and dedication to his or her work. Almost every company and educational institution sets strict rules based on their existence. The most common method used in colleges and schools or any other institution to mark attendance is to name each student and mark his or her presence which is the most commonly used method. The problem with this method is it takes time to pronounce all the words. The problem there is authenticity, where a representative is possible and personal mistakes are also possible. Alternatively, various companies, as well as educational institutions, use a personal identification method such as RFID, fingerprints, etc. Although we have the different options mentioned above, new needs are still emerging. As well as tracking attendees or markings, the Covid 19 outbreak raised additional temperature testing concerns in these systems. Companies and educational institutions made it mandatory to scan everyone before joining the organization. Therefore, a smart arrival tag system should be used instead of the traditional marking of attendees. We suggest an idea where marking is used to identify a student or employee's face and temperature test is also added to the attendance marking system. In this proposed system the camera module captures images of the installer and compares the image with the data and if it exists it will be stored directly on any storage device with the name and temperature of the appropriate

employee to identify potential Covid-19 patients and reduce the time spent on marking attendance

through the use of a large number of facial features. This paper describes the use, design, and conclusion of the system.

In the Paper [2], the program is intended for use with ultrasonic sensors, IR temperature sensor, and Arduino-connected camera. Presence is automatically marked this way and the compatible system can scan individual readers to see the temperature rise. The main purpose of this paper was to develop an attendance marking system using biometric-based temperature measurements in institutions.

# IoT based Covid band for health monitoring

Mrs. Vishalini Divakar  
Dept. of Electronics and  
Communication Engineering  
K S Institute of Technology  
Bangalore, India  
vishalinidivakar@gmail.com

Naveen G  
Dept. of Electronics and  
Communication Engineering  
K S Institute of Technology  
Bangalore, India  
navinaveen569@gmail.com

Varsha M S  
Dept. of Electronics and  
Communication Engineering  
K S Institute of Technology  
Bangalore, India  
gowdavarsha928@gmail.com

Sadhana M  
Dept. of Electronics and  
Communication Engineering  
K S Institute of Technology  
Bangalore, India  
sadhanagowda0702@gmail.com

**Abstract**— In the current situation of covid 19, the only way to protect the human lives is to take precautionary steps then to suffer. And also, frequently monitoring one's temperature and their closed ones will be a step ahead to control the disease in proper manner. For this prevention method, an idea of smart wrist band which consists of IOT Technology is proposed in this paper. Additionally, blood pressure, oxygen saturation and heart beat sensor, at frequent intervals. In this way the immediate information is sent to primary level user and also to the secondary level relatives with the help of IOT technology. Therefore, this compact and handy smart wrist band plays a major role in protecting lives by both monitoring and alerting the sufferers. A hardware prototype is also developed for the same and the results are found to be satisfactory.

**Keywords:** Health Monitoring, IoT.

## I. INTRODUCTION

In this modern time observing patient continuously is a difficult task which must be concerned. So, this operation system refers some procedures and basic necessities for patients who are consulted by doctors according to their facilities. So, by giving the medical needs through telecommunication technology which helps a patient to keep an account hold during a epidemic. As per the outcome observing a patient has led to an extreme characteristic response which can be easily declared as negative and positive where as others are requested to consult the doctor for intercede the sign of pain caused by it where the patients have to be kept in observation from which they can have an exact data of complete hospitalized patients. With help of real time tracking equipment some people have option like surveillance for a day where they can go back to their home with some important aspect such as breathing rate, oxygen level, heart beat and temperature of patient will be collected. To reduce the risk of exposure in medical field during pandemic, the PPE (Personal

Protection Equipment) and logistics were anticipated to repair. And this PPE method was only based on paper works which explains the design of sensors and instrumental measurement which are essential to collect the patient data while monitoring in electronic devices like computers and mobile phones. The major idea was to keep away the papers and take an immediate step against the epidemic to strengthen the preparation of national health system across India.

## II. LITERATURE SURVEY

[1] In this paper - Smart cap for prevention of diseases and social distancing using Arduino. In this paper it gets the information which is related to temperature and distance. Advantages - It is cost efficient. It is Easy to manufacture as it is less complex to compared in design. Disadvantages-In this paper PIR sensors are used as they cannot detect humans and also a heat emitting body. This is unable to detect mask which is an important factor for prevention of disease.

[2] In this paper - Role of smart technology to combat covid-19 successfully the mix of many devices like satellite monitoring, facial recognition in CCTV footage can be seen and independent automobile are used to operate a combat towards covid-19. Advantage - Technology used is very efficient and smart and lessens the collision of increasing the covid-19. Disadvantage - maintenance is too high.

[3] Wearable device for the detection of Covid-19 - this explanation brings us different devices that can be mounted on our body which prevent, detected Covid-19 this also makes the patient to grow interest of these wearable tool for massive outbreak. Advantages - The device can be used in early detection and prevention from the Covid-19, These are easily mounted. Disadvantages- Perhaps it would be costly and unbearable to wear various devices.

[4] The significance of core temperature -pathophysiology and

# Face Recognition For Automation Of Doorlock System

Mohammed Faizan Shafi  
Electronics and Communication  
Engineering  
KSIT  
Bangalore, India.  
mdfaizan5262426@gmail.com

Divakarbabu Y  
Electronics and Communication  
Engineering  
KSIT  
Bangalore, India  
divakarbabuy8050@gmail.com

Jishnu S  
Electronics and Communication  
Engineering  
KSIT  
Bangalore, India  
jishnusb125@gmail.com

M Nihitha Yadav  
Electronics and Communication  
Engineering  
KSIT  
Bangalore, India  
nihi.yadav25@gmail.com

Jayasudha B S K, Asst.Professor  
Electronics and Communication  
Engineering  
KSIT  
Bangalore, India  
jayasudhabsk@ksit.edu.in

**Abstract**—Security has persistently been a vital issue surrounded by the home or office. Face recognition system is an intelligent application, which can acknowledge and confirm a person's identity from sophisticated sources. The system is composed of the Doorbell which is interfaced with Raspberry pi, when a person presses the doorbell, the camera gets triggered and capture their face and it check for his or her face within its database. Smart doorbells allow home owners to receive alerts when a known/unknown visitor is at the door. This project is particularly based on image processing by porting the OpenCV library to the Raspberry Pi board. The eventual work in face recognition is the way to realize the most identical pictures between the tested and trained faces.

**Keywords**— raspberry pi, magnetic door-lock, Haar-cascade algorithm, openCV.

## I. INTRODUCTION

In the present state of affairs, the crimes are being increased exponentially, that is the requirements of security can also be represented as a condition so that one can develop and progress freely and with assurance that no harm may be done. Hence, we are introducing an automatic door-lock security system and home automation for the security purpose in day to day life. Camera is now enormously being used with the enlargement of its contents that is utilized in varied applications. One such is automatic door-lock security system using camera.

Interfacing of Raspberry-pi with camera to capture live images of person. We create a database of authorized person. Capturing current image, save and compare it with the database image. For instance, it capture the images of unidentified individuals and store it which can later be used to conclude the imposter who try to gain illegitimate access. Interface relay as an output.

In this present-day world, home security has the need of the hour for the improvement of society as a whole which in turn will help make our living space smart, so the concept of facial recognition to gain access to the house is an idea which is used to make our place of living more secure. A facial recognition system is a system which captures pictures

and verifies the identity of an individual person by using a digital camera.

The human face accepts a fundamental part in our community affiliation, passing on people's individuality. Using the human face as the key to security, biometric deft affirmation development has gotten enormous thought in the past a surprisingly long time due to its true capacity for a wide variety of usages. A facial verification system is a structure which gets facial pictures and affirms the personality of a man utilizing an incited camera. It is an application that is fit for recognizing or really taking a look at a man from a mechanized picture. One way to deal with this is by taking a gander at picked facial parts from the image and a face data set.

Because of the evolution of remote innovation, there are a few different of associations are presented like GSM, WIFI, and Bluetooth. Each of the connection has their own unique specifications and applications. Among the four popular wireless connections this is often implemented in project, WIFI is been chosen with its suitable capability. The capabilities of WIFI are a great deal to be implemented in the design. Also, most of the current laptop/notebook or Smartphone come with built-in WIFI adapter. It will gain a roundabout way reduce the expense of this system.

This mission advances the plan of home mechanization and security framework utilizing Raspberry pi, a credit measured PC. Raspberry pi gives the elements of a small PC, extra with its GPIO pins where different parts and gadgets can be associated. GPIO registers of raspberry pi are utilized for the result purposes. We have designed a power strip that can be easily connected to GPIO Pins of the Raspberry pi.

## II. LITERATURE SURVEY

Y. Januzaj [1] proposed constant access control for face acknowledgment utilizing, Raspberry pi rather than GSM administrations and hand-off. The restriction of the work was it had no control over the foundation light circumstance and surrounding light circumstances.

# Voice Assistant

A N Bhoomika Chowdary,  
Dept. of ECE  
K S Institute Of Technology  
Bangalore, India  
[bhoomikachowdhry@gmail.com](mailto:bhoomikachowdhry@gmail.com),

Darshan S,  
Dept. of ECE  
K S Institute Of Technology  
Bangalore, India  
[darshansrinivasa034@gmail.com](mailto:darshansrinivasa034@gmail.com)

Lavanya M  
Dept. of ECE  
K S Institute Of Technology  
Bangalore, India  
[lavanyam041@gmail.com](mailto:lavanyam041@gmail.com)

Deepthi Andani  
Dept. of ECE  
K S Institute Of Technology  
Bangalore, India  
[deepsandani@gmail.com](mailto:deepsandani@gmail.com),

Jayasudha BSK  
Dept. of ECE  
K S Institute Of Technology  
Bangalore, India  
[jayasudhabsk@ksit.edu.in](mailto:jayasudhabsk@ksit.edu.in)

## Abstract

*This paper describes the implementation of a voice-based home-automated system using an Arduino microcontroller. The system is aimed at designing an automated appliance control that is manageable and appropriate to use. The design comprised an Arduino UNO microcontroller board, Bluetooth module (HC-05), and an LCD. The Arduino controls any connected component and was programmed with C programming language by using Integrated Development Environment (IDE). Relays are used for the switching mechanism. Once the system is connected, the user controls the electrical appliances connected to the home-automated system, which can also be controlled using voice prompt with the help of an Voice Bot with the android smartphone. The system switches the home appliances ON and OFF using the android app, Bluetooth module, and voiced prompt.*

**KEYWORDS:** ARDUINO, BLUETOOTH MODULE, HOME-AUTOMATED SYSTEM, SMARTPHONE

## INTRODUCTION

Today, the development of artificial intelligence (AI) that can organize a natural human-machine interaction (through voice, communication, gestures, facial expressions, etc.) are gaining in popularity. One of the most studied and popular was the direction of interaction, based on the understanding of the machine by the machine of the natural human language. It is no longer human who learns to communicate with a machine, but a machine learns to communicate with humans, exploring his actions, habits, conduct and trying to become his personalized assistant. Virtual assistants are software programs that help to ease your daily tasks, similar as showing

weather reports, forming reminders, creating shopping lists etc. They can take commands through text (online chatbots) or voice.

Voice-based assistant needs a wakeup command or word to activate the listener, followed by the command. We have many virtual assistants, such as Siri, Alexa and Cortana. The smart home automation system that uses voice commands helps the user to control electronic appliances through voice commands. The module receives input signal from any a device which have voice commanding and with app. Compatibility such as smartphone. The smart home automation is very much valuable for handicap or aged people. This system solves the problem of switching on/off electrical appliances because when user just have to give voice command to control the appliance or electrical loads. The system is designed in such a way user can control all the appliances at once or can control each separately. The system will work by interfacing the on/off switches of electrical appliance or loads using relay after connecting relays in system the electrical switch works as two-way switch. The voice command is sent using an app to control the system, a built-in microphone and voice recognition system.

A micro-controller implemented in system, the micro-controller receives input signal from user device and sent signal to respective relay for turning on/off the electrical appliances connected with system such as bulbs, fan, air conditioner unit etc.

## LITERATURE SURVEY

The basic idea of a smart home system is to control and monitor household appliance wirelessly and verbally. This paper proposed computer-based wireless smart home system. The projected system consists of a programmed speech recognition system which identifies the spoken words and translates them into text command in MATLAB.



# Fingerspell Recognition Model Using Convolutional Neural Network and Computer Vision

*SHASHANK KASHYAP*  
Dept. of Electronics &  
Communication Engg  
K S institute of technology  
Bangalore, INDIA

*SUMUKHA VASISHTA*  
Dept. of Electronics &  
Communication Engg  
K S Institute of Technology  
Bangalore, INDIA

*SHREYAMS DK*  
Dept. of Electronics &  
Communication Engg  
K S institute of technology  
Bangalore, INDIA

*PRASHANTH SK*  
Dept. of Electronics &  
Communication Engg  
K S institute of technology  
Bangalore, INDIA

*JAYASUDHA BSK*  
Asst. prof ECE dept.  
Dept. of Electronics &  
Communication Engg  
K S institute of technology

**Abstract**—Conversing with people having a hearing disability is a major challenge. Deaf and mute people use hand gestures and sign language to communicate, but normal people face problems in recognizing their language by signs made. Hence there is a need for systems that recognize the different signs and conveys the information to normal people. There have been several advancements in technology and a lot of research has been done to help the people who are deaf and dumb. Aiding the cause we present a model using deep learning methods like convolutional neural networks and computer vision.

**Keywords:** signs, deep learning, convolutional neural networks, computer vision.

## I. INTRODUCTION

Although sign language has evolved naturally between languages spoken in the hearing-impaired community, they have nothing to do with spoken language and have different grammatical structures [1]. Detection systems need to identify the movement of the hand, facial expressions, and even the posture of the signer.

American Sign Language is the main sign language that uses one hand and is static but most other sign languages like Indian sign language and other languages use both hands and are dynamic [2]. Our fingerspell recognition model uses Convolutional Neural Networks (CNN) in real-time to translate a video of a user's signs into text. Our problem consists of three tasks to be done in real time:

1. Obtaining a video of the user signing (input)
2. Associating each frame in the video to a letter
3. Reconstructing and showing the most likely word from classification scores (output)

From a computer vision perspective, this problem represents a major challenge due to a number of reasons, including:

- Environmental concerns (e.g. lighting sensitivity, background, and camera position)
- Occlusion (e.g. some or all fingers, or an entire hand can be out of the field of view)
- Sign boundary detection (when a sign ends and the next begins)
- Co-articulation (when a sign is affected by the preceding or succeeding sign) [4].

Keeping all this in mind we have created our own dataset consisting of various possible lighting conditions, background, and skin tones so that our model is more efficient and accurate.

## II. LITERATURE SURVEY

[1] In this paper titled, "SIGN LANGUAGE RECOGNITION USING NEURAL NETWORK"

They have used a pre-trained GoogleNet architecture that predicts the American sign language characters correctly with first time users. They have primarily used convolutional neural network as their main algorithm .

[2] In this paper titled, "Sign Language Translator"

They have built a system that runs on Raspberry Pi and can act as a stand-alone device. They have used the Raspberry camera module to capture the fingerspells of the signer and the generated text/sentence is converted to audio with the help of a speaker module that is connected to the 3.5mm audio jack of the Raspberry Pi. The video captured from the camera module is processed using OpenCV, and the coordinates of the

# Automated Crowd Management and Energy Conservation System in Metro Using IoT

Chithritha G R  
UG Student,  
Dept. of Electronics and  
Communication,  
K. S Institute of Technology,  
Bangalore, Karnataka.  
chithrithagr@gmail.com

Dhanushree C  
UG Student,  
Dept. of Electronics and  
Communication,  
K. S Institute of Technology,  
Bangalore, Karnataka.  
dhanushree.c2000@gmail.com

Harshitha S  
UG Student,  
Dept. of Electronics and  
Communication,  
K. S Institute of Technology,  
Bangalore, Karnataka.  
harshithanaik2000@gmail.com

Meghana B S  
UG Student,  
Dept. of Electronics and  
Communication  
K S Institute of Technology,  
Bangalore, Karnataka.  
meghanabs010301@gmail.com

Mr. Sampath Kumar S  
Assistant Professor,  
Dept. of Electronics and  
Communication  
K S Institute of Technology,  
Bangalore, Karnataka.  
sampathkumars@gmail.com

**Abstract:** With the ever growing global population, crowding in public transport is becoming an increasing menace. Public transport systems around the world have remained largely the same over the past several decades although the population they serve has burgeoned. This paper aims to demonstrate a low cost IoT based solution to the crowding problem by using smart seats that can detect and display the seat occupancy status in real time over an internet or mobile application.

**KEYWORDS:** IoT, Crowd management, Blynk App, ThingSpeak.

## I. INTRODUCTION

The detection of crowded areas was chosen from the different applications mentioned so far with so

there are numerous research focused on the design of systems that are expected to perform in crowded settings, but they do not explain what is termed "busy." As a result, an evaluation of the existing literature on the detection of congested situations was conducted. The data revealed that it was limited, and that the researchers arbitrarily set the threshold to separate "packed" from "not crowded" conditions in previous studies. As a result, the goal of this research is to develop a mechanism for determining whether a location is congested or not, as well as a threshold for separating those circumstances using mobility data.

## II. LITERATURE REVIEW

[1] **A Low-Cost IoT-Based Public Transportation Crowd Management System:** The study demonstrated crowd control utilising an IoT technology, in which the crowd is handled by a mobile application. This paper depicts a crowd

# Bidirectional Visitor Counter

Chaitra P  
Electronics and Communication  
Engineering  
KSIT, Bengaluru  
chaitraputtaswamy18@gmail.com

Likitha H  
Electronics and Communication  
Engineering  
KSIT, Bengaluru  
likithah01@gmail.com

Monika V Arya  
Electronics and Communication  
Engineering  
KSIT, Bengaluru  
varyamonika@gmail.com

Krupa A  
Electronics and Communication  
Engineering  
KSIT, Bengaluru  
ashwathkrupa@gmail.com

Mr. Sampath Kumar  
Asst. Prof Electronics and  
Communication Engineering  
KSIT, Bengaluru

*Abstract: Science and Technology have gotten along relatively well in recent years. Microcontroller technology is evolving at a breakneck pace. We frequently need to keep track of the number of individuals entering areas like malls, conference rooms, retail outlets, metro stations, and special events. The purpose of monitoring places is to keep track of who enters and exits a location, which can help us determine whether it is crowded or not, as well as determine conversion rates in retail businesses. Let's learn how to make a Bidirectional Visitor Counter with Arduino and IR sensors to count the number of people entering and exiting a location. Science and Technology have gotten along relatively well in recent years.*

**Keywords:** Arduino , IR sensors, LCD display, Fan

## I. INTRODUCTION

This project provides the greatest option by keeping track of how many people are in the conference/seminar halls. Using IoT, the lights and fans in a room are controlled based on the number of visitors in the room,

The system keeps track of who enters and exits the auditorium, hall, or other location where it is installed. The system recognizes the visitor's entry and exit based on the interruption of the sensors. [2]

Automatic technology is one kind of essential demands in today's generation, as the standard of living continues to rise. There is a pressing need to design circuits that will make our lives considerably easier than they are now. The Arduino-based bidirectional visitor counter is a useful and advantageous circuit for counting the number of people in a certain room. It is simple to use and maintain. We will also include a Fan in this model, which will operate as an automatic switch to turn on and off a fan. This will aid in energy conservation as well as assisting any blind person that enters the room. In this project, IR sensors, an LCD display, and a few other components were employed

## II. RELATED WORK

and the lights and fans are automatically controlled based on the intensity of the room, and if there is a fire accident, it gives an alarm and immediately blows water into the fire place. [1]

Electronic appliances such as lights, fans, and coolers will be turned on and off according on the amount guests in the industry. This automation will save a significant amount of energy. There will also be a temperature and humidity sensor to detect an industry's temperature. If the temperature rises above

# Parking System with Automated Billing

Dheemanth KN  
department of electronics and  
communication  
KS institute of technology  
Bangalore, INDIA  
dheemanth4562@gmail.com

Danesh Raju V  
department of electronics and  
communication  
KS institute of technology  
Bangalore, INDIA  
daneshraju2002@gmail.com

Chiranthana Yogananda .K  
department of electronics and  
communication  
KS institute of technology  
Bangalore, INDIA  
chiru201297@gmail.com

Sampath Kumar S  
department of electronics and  
communication  
KS institute of technology  
Bangalore, INDIA  
sampathkumars@ksit.edu.in

**Abstract**— this paper is to present an effective billing system for a parking management, the aim is to proposed a system that requires the least amount of human intervention and has the ability to calculate the time between the user log in and log out and deduce the appropriate fee. The log in time for each user is trimmed by creating a efficient and automated billing system, allowing the user experience to be fluid and unrestrained. It also contributes to decrease in automobile emissions by shortening the log in time. This would result in prevention unnecessary fuel consumption, reduces pollution in the parking area, and it also reduces the amount of human participation in working process to the minimum. This working is as follows, First we use the RFID tags and RFID reader to identify the user and then we note down the specific log in time later when the user log's out , the specific time at that instant is recorded and the duration during which the car was parked is calculated and at the end the finalized bill is created and the specified amount is deduced form the user database. This system is built on an ARDUINO UNO R3 microcontroller, which uses small in size (width 53.4 mm , length 68.6 mm) and has low requirement for power for its working and it works in real time with an Real Time Clock module (DS1307), Radio Frequency Identification tags, and a RC522 reader module.

**Keywords**—billing system, Arduino Uno, rtc module, rfid tags, rc522 reader module, Arduino IDE

## I. INTRODUCTION

Currently, the manual parking systems in use at many institutions are a wastes time and is inefficient for vehicle mobility. People find it inconvenient or to be specific bother some to have to wait in queue to get their things do. Same is true for parking , where they are need to wait for their turn. Because of increase in number of automobiles being used, traffic has become a major issue in recent years. The focus of this paper is to automate the parking area payment system, which has been carried out manually till recent years and is inaccurate, time consuming, and exhausting to execute on a routine basis. This study aims to minimize the user time consumption and create a practical and functional billing system that requires the least amount of human participation.

We expect the billing system to be real-time and cashless, which would save more time.

### A. Method of Automatic Billing

First, we need to calculate the duration of time the user has parked the vehicle in the parking area. This is done by saving the entry and exit time and finding out the duration and after this is found, we need to calculate the fee for the user. This is done by converting the duration of parking time into one format of time (i.e. Minutes, Seconds, or Hours). After this is done we need to multiple this time duration with the value of amount that needed to be deduced for that specific format of time. (i.e. If we choose the minute format then we need to multiple the time with the value of amount that needed to be deduced for one minute during his stay in the parking lot).

### B. RFID Technology

Electromagnetic fields are used by radio-frequency identification (RFID) to automatically recognise and track tags that are fastened to objects. A radio transmitter, receiver, and small radio transponder make up an RFID system. The tag transmits digital data, often an inventory identification number, back to the reader when activated by an electromagnetic interrogation pulse from a close-by RFID reader device. You may monitor inventory items using this number. An RFID tag is made up of three parts: a substrate, an antenna, and a microchip (an integrated circuit that stores and processes data as well as modulates and demodulates RF signals). The tag data is stored in a non-volatile memory. The RFID tag includes either fixed or programmable circuitry for processing the transmission and sensor data. RFID tags can be active, inactive, or passive with battery support. An active tag is powered by an on-board battery and periodically broadcasts its ID signal. A battery-assisted passive tag's small on-board battery cannot operate without an RFID reader. A passive tag is less expensive and smaller because it doesn't require a battery. It makes use of radio energy.

RFID systems may be divided into groups based on the kind of tag and reader used. There are three types: The reader only detects radio signals from active tags in a passive reader active tag (PRAT) system. The PRAT system reader's changeable reception range, which spans from 0–600 m to 1–2,000 ft, provides versatility in applications like

# AI Based Home Automation

VIDYASAGAR R  
Electronics and Communication  
engineering  
K S Institute of technology  
Bangalore,India  
hiremathsagar123@gmail.com

VENKATESH M N  
Electronics and Communication  
engineering  
K S Institute of technology  
Bangalore,India  
venkatesheravenky@gmail.com

SURYA K B  
Electronics and Communication  
engineering  
K S Institute of technology  
Bangalore,India  
suryarajukb@gmail.com

SAMPATH KUMAR  
ASSISTANT PROFESSOR  
Electronics and Communication  
engineering  
K S Institute of technology  
Bangalore,India

**Abstract:** *In the present scenario the crimes are increasing exponentially, arising a need of security. Security can also be described as a condition so that one can develop and progress freely and with a faith that no harm may be done. Hence, we are introducing any automatic door lock security system and home automation for the security purpose. Camera is now enormously being used and with the development of its content that is used in various applications. One of such is automatic door lock security system using camera.*

*The Internet of Things (IoT) is the interconnection of uniquely identifiable embedded computing devices within the existing Internet infrastructure. Typically, IoT is expected to offer advanced connectivity of devices, systems, and services that goes beyond machine-to-machine communications (M2M) and covers a variety of protocols, domains, and applications. The interconnection of these embedded devices (including smart objects), is expected to user in automation in nearly all fields, while also enabling advanced applications like a Smart Grid. Things, in the IoT, can refer to a wide variety of devices such as heart monitoring implants, biochip transponders on farm animals, electric clams in coastal waters, automobiles with built-in sensors, or field operation devices that assist fire-fighters in search and rescue. Current market examples include thermostat systems and washer/dryers that utilize wifi for remote monitoring.*

*Interfacing of camera to capture live face images. Create a database of authorized person if they exist. Capturing current image, save it and compare with the database image. Interface GSM module to send alert to authorized person while unlocking the locked door in the form of SMS and CALL. The project can also be used for surveillance. For instance, it can capture the images of unidentified individuals and store it which can later be used to determine the impostors who tried to gain illegitimate access. Interface relay as an output. And additional home automation system is used to control the home appliance like fan and light using mobile application. With help of Wi-Fi connected for the model using TCP/IP.*

## I. INTRODUCTION

appropriate action. Personal computer (PC) is associated with the microcontroller, the entire system will not work if PC is crashed or non-Function.

The "Home Automation" concept has existed for many years. The terms "Smart Home", "Intelligent Home" followed and has been used to introduce the concept of networking appliances and devices in the house. Home automation Systems (HASs) represents a great research opportunity in creating new fields in engineering, and Computing. HASs includes centralized control of lighting, appliances, security locks of gates and doors and other systems, to provide improved comfort, energy efficiency and security system. HASs becoming popular nowadays and enter quickly in this emerging market. However, end users, especially the disabled and elderly due to their complexity and cost, do not always accept these systems.

Due to the advancement of wireless technology, there are several different of connections are introduced such as GSM, WIFI, and Bluetooth. Each of the connection has their own unique specifications and applications. Among the four popular wireless sections that often implemented in HAS project, WIFI is being chosen with its suitable capability. The capabilities of WIFI are more than enough to be implemented in the design. Also, most of the current laptop/notebook or Smartphone come with built-in WIFI adapter. It will indirectly reduce the cost of this system.

## II. LITERATURE SURVEY

**In [1] a Door lock access system** which consists of three subsystems: to be specific face recognition, face detection, and automated door access control. Face recognition is actualized by using the PCA (Principal Component Analysis). The door will open itself for the known person in command of the microcontroller and caution will ring for the unknown person. Demerit of this system is input images are taken through a web camera continuously until the 'stop camera' button is pressed. Somebody is required at the location to check unauthorized person's images or status of the system and take further

**In [2] Embedded Image Capturing System Using Raspberry Pi.** In this work, they captured the image and compared it with the database but the limitation was the system couldn't work properly in the ambient light condition.

# CNN Based Self-driven Autonomous Car

Mr. Sunil Kumar G R  
Dept. of ECE  
K S I T  
Bangalore,India  
sunilkumargr@ksit.edu.in

Gagan Kumar G  
Dept. of ECE  
K S I T  
Bangalore, India  
gagankumar2299@gmail.com Guided

Jagruti. Pai  
Dept of ECE  
K S I T  
Bengaluru, India  
jagrutipai2001@gmail.com

Dileep V  
Dept. of ECE  
K S I T  
Bangalore ,India  
dileepven@gmail.com

*Abstract— According to the Society of Automotive Engineers there are six international standards set to know the level of driving automation. In this paper we are proposing a better solution to process the Input data using High Dynamic Ranging technique. Few start-up companies are experimenting on the autonomous vehicles, these vehicles fail to reach the roads due to many reasons like improper processing of the input data from the sensors, Environmental causes, highly expensive hardware. In which multiple input data is processed at least bit rate and the captured image data is acquired completely with less distortion. By using (CNN) Convolution Neural Network, we can find the obstacles and traffic signs, can be detected perfectly when compared to the (CNN) Convolution neural network methods. In convolution neural network, the networking of every nodes of the system. are interconnected to each other in the system in which we can obtain a much responsive output comparing with the present techniques for data collection. The Master device (Raspberry-pi) which has a processing unit and the controller unit (Slave device) which are set up on a single board, which makes the system function much faster than the other systems.*

*Keywords—Raspberry-pi, CNN, SENSOR, MASTER-SLAVE, TRAFFIC SIGNS*

## 1. INTRODUCTION

In the recent times many start-up are into building self-driving cars. All of which most of the time fails to detect the right inputs for processing a perfect output today we are here with our advancement in acquiring efficient data input through the WSN system processing and HDR imaging techniques. Most of them use the conventional sensor system to control the vehicle.. There are three major modules

1. Wireless Sensor Network. 2. Image Processing  
3. Machine Learning. Most of these cars use 3-D Light Detection and Ranging techniques to map the obstacles, due to which there is a high probability of inaccurate image detection, that leads to malfunctioning of system. The existing self-driven cars are highly expensive and complicated. The traditional techniques used to detect objects such as traffic signal, signs etc., are by mentioning them. Some systems use cloud-based data processing systems which most of the time causes a delay between the transmission of data from the cloud to the car controller.

## II. LITERATURE SURVEY

[1] In this paper titled "A Vision-Based Method for Improving the Safety of Self-Driving" In this paper, Author propose a control strategy with environment identification to minimize the cost but achieve the effect of expensive Multiline Lidar. We use computer vision and deep learning to train existing data set.

[2] In this paper titled "Safety Analysis based on critical scenarios and collision avoidance of highly automated vehicle" Safety of automated factor to reduce the driving collision and to improve people's Feelings of road traffic safety. They have described two effective measures to control the Risk and Reduce the damage i.e. backward collision warning and anti-collision warning and anti-collision lane changing.

# Smart Anti-Piracy System

Sirisha M  
Department of ECE  
K.S.Institute of Technology  
Bangalore, India  
sirisha1052000@gmail.com

Sunil Kumar G R  
Department of ECE  
K.S.Institute of Technology  
Bangalore, India  
sunilkguntur@gmail.com

Sanjana B  
Department of ECE  
K.S.Institute of Technology  
Bangalore, India  
sanjanabadarinath2000@gmail.com

Surekha Borra  
Department of ECE  
K.S.Institute of Technology  
Bangalore, India  
borrasurekha@gmail.com

Pruthvi Dinesh  
Department of ECE  
K.S.Institute of Technology  
Bangalore, India  
pruthvi.sunitha@gmail.com

**Abstract**— Movie Piracy is increasing these days, and it has a profound impact on the economic growth of film industries all over the world. Hence curbing piracy has become a critical step in avoiding massive losses to the film industry. This paper proposes a thermogram based anti-piracy system using Machine learning models. A local dataset is created by capturing the images in different scenarios by employing a thermal camera. AlexNet is used for extracting the features from captured images and the extracted features are trained with several Machine Learning models in MATLAB for their performance evaluation. The images captured in real-time are processed to extract the features and then directed to the classifier to predict the anomaly class. The alert message is sent to theatre officials regarding the presence of active recording device. An accuracy of 99.7 % is achieved with Support Vector Machine (SVM) model on the local dataset.

**Keywords**—Camcorder, Movie Piracy, Thermogram, AlexNet

## I. INTRODUCTION

Cinema piracy is emerging as the biggest threat to the Film Industry in recent years. It has grown tremendously, making it easier than ever to access pirated movies on online platforms at one's fingertip. An increase in piracy has a severe impact on the economic growth of film industries all over the world. It is inferred from a survey that pirated videos receive over 230 billion views every year. As well, a study says that in the United Kingdom, about 30% of the population watch pirated movies, costing the industry £500 million every year. In India, piracy is considered as an offense, and pirates are imprisoned for three years with a penalty of 10 lakh rupees as per the Cinematograph Act of 2019. Apart from this, filmmakers, producers, independent creators, and distributors lose interest in making sequels and remakes. Lower-class artists risk their job, welfare, and pensions.

The illegal copying of movie for the purpose of selling it at a lower market price is referred to as movie piracy. Some of the ways in which piracy can occur are Camera recording, DVD & VOD ripping, Telesync, Digital distribution copy, Telecine, and WEB-DL. Camcorder piracy can be classified into pre-release and post-release piracy. In pre-release piracy, the movie is pirated during exclusive

screenings to sponsors, reviewers, and VIPs. During this time, piracy may occur in two possible ways. In one of the ways, guests can record the movie and make the copy available for unauthorized dissemination. These copies are generally of low audio and video quality. This kind of piracy is known as cam. On the other hand, while the movie is being projected, theatre operators can record the film by employing camcorder mounted on the tripod at the theatre backend. A telesync system is used to derive sound from the audio system directly. In post-release piracy, both theatre operators and audiences can pirate the movie and sell it at a lower price or share the pirated videos freely on social media [1-3].

In this paper, an antipiracy system is developed using machine learning techniques by employing a thermal camera in a Theatre environment. The proposed approach focuses mainly on finding the presence of active camcorders held by pirates in the theatre, thereby reducing piracy in real time. Section 2 presents literature survey, Section 3 presents the proposed piracy detection approach, Section 4 presents the results, and Section 5 concludes the paper.

## II. RELATED WORK

Kumar et al. [4] presented a system with IR transmitters connected horizontally and vertically to the servomotors, causing them to rotate at +45 and -45 degrees. This configuration of IR emitters will cover the entire screen. When the video is recorded, it is captured such that a matrix of transmitted rays emerges on the screen due to the movement of IR emitters. If the power supply to the IR emitters is interrupted, the risk of piracy is more. Hence to overcome this problem, the transmitter and the projector are interconnected so that the projector does not switch ON independently. This connection is established by integrating a password system using keypad. This ensures that the power supply to the IR transmitters, servomotors, and projector is denied until the user enters correct password. The transmitter ejects infrared rays when powered ON. Then a signal is received by the receiver which is fed as an input command to the Arduino Uno microcontroller which activates a relay. The relay interconnects the projector and power supply, acting as a switch. Hence it allows the projector to start the movie projection. The projector will not switch on if there is any

# Drone Sanitizer

Mrs V Sangeetha  
Dept. of Electronics and  
Communication Engineering  
K S Institute of Technology  
Bangalore, India  
nvsangeetha@gmail.com

Ananya Ananth  
Dept. of Electronics and  
Communication Engineering  
K S Institute of Technology  
Bangalore, India  
ananyaananth006@gmail.com

Megha R  
Dept. of Electronics and  
Communication Engineering  
K S Institute of Technology  
Bangalore, India  
megharamesh2201@gmail.com

Ashritha S C  
Dept. of Electronics and  
Communication Engineering  
K S Institute of Technology  
Bangalore, India  
ashrithasc35@gmail.com

Anagha S  
Dept. of Electronics and  
Communication Engineering  
K S Institute of Technology  
Bangalore, India  
anagha.satish30@gmail.com

**Abstract**—The epidemic of COVID-19 has disrupted social and economic norms. With the evident need for disinfection and sanitization. The drone can sterilize areas without the need for human intervention using remote inspection. The Quadcopter may be controlled from a distance, allowing for remote monitoring and cleaning of the affected areas. Sanitizer is carried in a tank by the quadcopter, and the liquid is dispersed using the sanitizer spray mechanism. The signal from the ESC is used to control the speed. As a result, propulsion will be generated, allowing the drone to travel in the desired direction. This system is powered by an 11.1V Li-Po battery. A motor is used to dispense the sanitizer. When the engine is turned on, the sanitizer is pumped via the pipes.

**Keywords:** Covid-19, Drone, Quadcopter, Sanitizer, ESC, Li-Po Battery, Motors.

## I. INTRODUCTION

Covid-19 has resulted in a global public health calamity that has never been seen before. The Corona virus outbreak has had a huge impact on people's health, economies, and lifestyles all around the world. In order to overcome the pandemic's challenges, we should investigate any further strategies for combating the new coronavirus.

In today's world, drone technology is fairly common and adaptable. Drones are utilized as both a weapon and a fighter's ally in long-range battle. Drones, as the fastest-growing section of the aviation industry, will be a one-of-a-kind tool in the hands of experts fighting the outbreak. It's previously been demonstrated to work in a variety of situations, including spraying herbicides on agricultural fields.

Drones could be used to carry out the sanitization procedure as well. A drone-mounted sprayer has been designed to apply sanitizing sprays in regions that require disinfection while reducing the requirement for human participation. The device is extremely significant in the operation of the drone system; the drone is effectively controlled by a remote controller. Motors are used to pump

sanitizer via pipes, which is then sprayed through nozzles, sanitizing the required locations. As a result, the project's primary goal is to sanitize areas that require less human interaction and to assist in the hunt for good or best sanitization utilizing drones to aid in the fight against the COVID-19 epidemic.

## II. LITERATURE SURVEY

Dwi Mutiara Harfinet et al. [1] has proposed spraying disinfectant indoors with a drone or unmanned aerial vehicle (UAV). Drones that are easy to control and can reach multiple portions of an area in a large building with only one controller can limit human physical contact. The quadcopter UAV employed in this study has four propellers, each of which is powered by an 11.1 Volt brushless motor. The SP Racing F3 flight controller is in charge of a 2200 KV BLDC motor. The motor is used as a propeller drive, and the current source is LiPo 3S. A disinfectant solution of 200 mL is carried and sprayed. These drones are used to keep an eye on high-risk individuals, so they don't leave their homes. It can be used for food and medicine delivery for those patients.

Shubham Kishor Patil et al. [2] For the pandemic, a health monitoring and sanitizing drone has been proposed. Drones are becoming more common in our daily lives, and there is a high demand for them in the market. They used a quadcopter in this article because of its durability and strong weightlifting capability, which allows it to lift up to 4 kg of weight with ease, and they also added a health monitoring system so that the drone could be handled from a single fixed place. In this study, the MLX 90614 temperature sensor is used, which gives the drone more stability. It also contains a receiver that determines information like location, time, and velocity, and it must be provided with a trail that can help the drone.

Tuton Chandra Mallick et al. [3] The idea of an autonomous unmanned aerial vehicle (UAV) operated by wireless technology via a graphical application was proposed in this paper (GUI). This proposed design is capable of flying autonomously as well as automatically tracing pre-loaded missions. Drone computations are what allow it to fly both



# Bluetooth Robot Control Using Smartphone

Akshitha  
Department of ECE  
K.S Institute of Technology  
Bangalore, India  
naiduchikki@gmail.com

Manogna K M  
Department of ECE  
K S Institute of Technology  
Bangalore, India  
manognakm14@gmail.com

M Lokeshwari  
Department of ECE  
K S Institute of Technology  
Bangalore, India  
lokeshwari9538@gmail.com

Anitha. S  
Department of ECE  
K.S Institute of Technology  
Bangalore, India  
anitha24122001@gmail.com

Sangeetha. V  
Department of ECE  
K.S Institute of Technology  
Bangalore,India  
sangeetha.v@ksit.edu.in

**ABSTRACT:** This project aim is to design a Robot Control by Bluetooth. The functioning is based on Arduino microcontroller, Bluetooth module, dc motors and motor drivers. Arduino uses ATmega328 microcontroller. Our plan is to code the entire functioning using programming. Then the code will be simulated on software and later it can be interfaced with the hardware. Android app controls movement of the robot. We have chosen this for our mini project as robotics played a major role in our day-to-day activities. The gap between Robot and human beings are reducing with the introduction of new technologies. This paper will give the detailed explanation of motion technology through android smart phone with built in Bluetooth module to control the movement of a robot. Microcontroller controls the speed and direction of the Bluetooth module. The remote is android app. Bluetooth is used for the communication between microcontroller and android app. Bluetooth is an example for wireless communication.

**Keywords**—Bluetooth, Arduino microcontroller, DC motors

## I. INTRODUCTION

The current development is much enhanced mainly in the area in the technology such as communication which has become a daily need. Technology is rapidly increasing in many fields especially in robotics. Smart phone is now core part of humans life. Android is a software platform many mobiles. Which includes operating system based on modified version. And other certain open source software, designed primarily for touch screen devices such as smart phone and tablets which ensure safe and secure operating system. By this we can say that smart phone will provide great benefits for commercial, industrial and another general purpose uses. Our main purpose of project Bluetooth robot control using smart phone. We are using Bluetooth HC05. Where HC05 is a Bluetooth module it is designed for wireless communication. It can be operated in the range of 4-6volts of power supply. There is a one function which

can control the directions of robot using a Bluetooth connection found on smart phone. The use of wheeled robots has greatly increased for industrial financial profits, both in terms of operations and materials. Vehicles will move in all directions such as Front movement, motors will be moved in the same direction. Backward movement, the motors will be moved in a opposite direction. For left and right movements either both the motors will rotate nor both the motors will stop through the mobile app by the user controller. A DC motor is a electrical motor that converts the electrical energy into mechanical energy. DC motors have some internal mechanism either electro mechanical or electronic to control the direction of current. Place of robot can be reprogrammable and tool can be interchanged to provide a required or multiple application. Arduino is a microcontroller chip ATmega328p, it is used as a RISC (reduced instruction set computer) instruction. Where the chip can be interfaced with Bluetooth module through UART(universal asynchronous receiver transmitter) protocol and the code can be written based on embedded c language. The robot has a wheel driven system on both of the wheels. Each wheel of the robot is connected using a DC motor.

## II. LITERATURE SURVEY

Many reserches had worked for improving the Bluetooth controlled robotic car which involves the different technology and serve the different purpose. The aim of the design is to decrease the human efforts software programs controls these devices .The main objective of creating the robot is to make use of functions of robotic service in lower cost and controlled using a android devices which most of the people having. A

# NFC and Coin Based Stationary Vending Machine

DILIP KUMAR C N  
Dept of ECE  
K S Institute of Technology  
Bangalore,India  
cndilipkumar7@gmail.com

V SANGEETHA  
Assistant Professor  
Dept of ECE  
K S Institute of Technology  
Bangalore,India  
nvsangeetha@gmail.com

DEVARAJ M  
Det of ECE  
K S Institute of Technology  
Bangalore,India  
devaraj221100@gmail.com

KISHORE R  
Dept of ECE  
K S Institute of Technology  
Bangalore,India  
ravillak3@gmail.com

**Abstract:** Portable vending machines are very useful devices for dispensing small, easily available necessary equipment for the use of man. The aim is to construct an automatic vending machine prototype model, which can be installed in schools, colleges, hospitals other public places to dispense pens, pencils, and sanitary napkins during needs with appropriate mechanical designs for item collection. Also, microcontroller circuitry for coin checking, and dispensing for items is to be proposed and implemented in realtime

Since their introduction, vending machines have become an increasingly important distribution channel in the private sector. In Educational institutions and office stationery vending machine is of great importance. This System proposes is based vending machine that dispatches A4 sheets once the RFID card is read. The users can select the required item after the card is scanned and collect the item in the output unit. The system is divided into three parts, the first part deals with the scanning of RFID which provides cashless payment. The second one is the programming unit which is implemented using  $\mu C/OSII$ . The third part is the display unit which displays information and delivers the required item based on the information sent from the microcontroller. An embedded system vending machine is designed to achieve and portable machine that can sell items automatically. Automatic vending machines are not that common in our country. Hence implementing such a machine in real-time will be of great use for people. The advantage of the machine is it requires nomanpower, consumes less power, occupies less space maintenance free simple in operation portable. The objective is to develop a vending machine prototype model for vending the items by credit or transaction. The availability of the items is also checked. It finds its application mainly for students.

**Keywords:** Vending Machine, piece of equipment.

## I. INTRODUCTION

A Vending machine is an automatic machine that sells food such as canned soups and packaged sandwiches, snacks such as potato chips, chocolate bars, stationery, and candy) hot drinks (coffee, tea, and hot chocolate); cold drinks (juice, bottled water, soft drinks, and in some cases, milk or chocolate milk); or other items such as newspapers and stationery. The first modern coin-operated vending machines were introduced in London in the United Kingdom in the early 1880s, dispensing postcards. The machine was invented by Percival Everitt in 1883 and soon became a widespread

feature at railway stations and post offices, dispensing postcards, and notepaper. The Sweetmeat Automatic Delivery Company was founded in 1887 in England as the first company to deal primarily with the installation and maintenance of vending machines. After paying, a product may become available by the machine releasing it, so that it falls in an open compartment at the bottom, or into a cup, either released first, or put in by the customer, or the unlocking of a door, drawer, or turning of a knob. Some products need to be prepared to become available. For example, tickets are printed or magnetized on the spot, and coffee is freshly concocted. One of the most common forms of vending machine, the snack machine, often uses a metal coil that when ordered rotates to release the product. The main example of a vending machine giving access to all merchandise after paying for one item is a newspaper vending machine (also called vending box) found mainly in the U.S. and Canada. It contains a pile of identical newspapers. After a sale, the door automatically returns to a locked position. A customer could open the box and take all the newspapers or, for the benefit of other customers, leave all of the newspapers outside of the box, slowly return the door to an unlatched position, or block the door from fully closing, each of which is frequently discouraged, sometimes by a security clamp.

## II. LITERATURE SURVEY

**In [1] A mobile robot vending machine for beaches based on consumers' preferences and multivariate methods[2014]**

The paper illustrates how multivariate statistical techniques, namely factor and clusters analyses, can be used to examine the perceptions and preferences of customers and to support the development of a new energetically independent autonomous mobile robot vending machine for food distribution on beaches. Concerning the initial product assortment to be carried by the robot, nine food product items, many of them healthy, were identified; factor analysis identified that the respondents used seven main design dimensions when they assessed the robot, namely "Convenience", "Menu", "Automation", "Distant Interaction".

## Intelligent Packaging System

Harsh Sharma Mehra  
Department of Electronics and  
communication  
K.S Institute of Technology  
Bengaluru, India

G.J Nithin  
Department of Electronics and  
communication  
K.S Institute of Technology  
Bengaluru, India

Raj Krishna  
Department of Electronics and  
communication  
K.S Institute of Technology  
Bengaluru, India

Praveen A  
Assistant Professor Dept.  
ECE  
K.S Institute of Technology  
Bengaluru, India

Dinesh Kumar Nayak  
Department of Electronics and  
communication  
K.S Institute of Technology  
Bengaluru, India

**Abstract**—The Intelligent Packaging solution aims to use an electronic packaging solution to combat the problem of opening packages during transportation and also to measure the inner and outer atmosphere of the package. IPS uses many sensors that continuously track the physical parameters inside the package to ascertain if the package has been opened, or there has been some rise in the temperature. Once this alert has been sent to those concerned, they can take necessary action. If there is no alert and a normal delivery takes place, the customer uses his/her mobile phone to scan a QR code displayed on the IPS kit. This will result in an OTP that is received at the customer's mobile number and entering the OTP will reset the device. The proposed system ensures that the customer receives the assured products.

**Keywords**—Arduino mega 2560, Node MCU, MEMs Sensor, IR sensor, LDR, GPS, LCD Display.

### 1. INTRODUCTION

The Intelligent Packaging System solution aims to use electronic packaging to combat the problem of tampering with packages during transit and monitor the product's characteristics and the inner and outer atmosphere of the box. The project IPS aims to use electronic packaging solutions to trigger an alert when a package is opened effectively. Monitoring is done by using many sensors in a failsafe system. The problem with single sensor-based systems is that they do not correlate data from different means. The proposed method has many sensors like GPS and IR that continuously track physical parameters inside the package during transit to ascertain if the box has been opened or if there has been some rise in temperature (for pharmaceutical and temperature-sensitive products). Once this alert has been sent to the manufacturer, they can take necessary corrective.

If there was no alert and a standard delivery took place, the customer would have received a damaged product. Once the delivery takes place, the customer uses their mobile phone to scan a QR code displayed on the IPS kit; this will result in an OTP received at the customer's mobile, and entering the OTP will open the kit will reset the device. The IPS module is then removed from the delivery box and given to the delivery executive to be reused again.

Internet of Things (IoT) isn't only an exciting research topic and a booming industrial trend. Although the essential idea is to bring things or objects online to be available to all, there are various approaches because an IoT system is very application-oriented. Some problems that arise with the packaging of products are difficulty and inaccuracy in determining appropriate packaging solutions consistent with the type and condition of the merchandise to be packed. The incorrect decision of the packaging option can cause a loss in quality and physical damage to the product. Packed products might get spoilt, especially perishable and time-sensitive products. The magnetic lock could be a more practical and cost-efficient solution, especially for parcel delivery. The functionality is often managed locally. Data security is a significant concern, and thus the system is fully compliant with all data protection standards. No resident data is stored locally, thanks to the enterprise-level cloud-based control system. With the exponential rise of eCommerce, Intelligent packaging solution helps with the increasing need to manage online purchase deliveries effectively.

Internet of Things (IoT) is not only a promising research topic but also a blooming industrial trend. Some problems that often arise in the packaging of products are difficulty and inaccuracy in determining appropriate packaging options according to the type and condition of the product to be packaged. The incorrect decision of packaging option can cause quality loss, physical damage, and spoilage of the packed products, especially perishable and time-sensitive products. Data security is of primary concern, and the system is fully compliant with all data protection standards. With the rise of e-commerce, there is an increasing need to manage online purchase deliveries

# Automated Toll Collection System Using RFID

Preetham G H  
Dept. of Electronics &  
Communication Engg.  
K S Institute of Technology  
Bangalore, INDIA.  
Preethamraj004@gmail.com

Nithin D  
Dept. of Electronics &  
Communication Engg.  
K S Institute of Technology  
Bangalore, INDIA.  
nithinbngl@gmail.com

Pavan Kumar G R  
Dept. of Electronics &  
Communication Engg.  
K S Institute of Technology  
Bangalore, INDIA.  
pavankumar3052001@gmail.com

Praveen Kumar N  
Dept. of Electronics &  
Communication Engg.  
K S Institute of Technology  
Bangalore, INDIA.  
Praveenkumarpy697@gmail.com

Praveen A  
Prof. ECE Dept.  
Dept. of Electronics &  
Communication Engg.  
K S Institute of Technology  
Bangalore, INDIA.  
praveena@ksit.edu.in

**Abstract**—In India, as the traffic has been increased due to the manual toll collection system. So the need to develop an efficient way of collecting toll taxes. Automated Toll Collection System is one of the way. Radio frequency identification i.e., RFID, is used. So instead of waiting in long queues for Manual Toll Collection, the user can just tap the RFID card on the RFID reader and can pass the toll plaza.

**Keywords**—RFID Card, RFID Reader, Toll Plaza.

## I. INTRODUCTION

Since we are living in a fast growing world, in which transportation is the decisive factor for every country's economy.

Therefore the process to implement new ideas on transportation will never stop. The use of RFID cards or tags in automatic toll collection system will further improve the system and makes it more complete.

As we see longer queues at the toll plaza's due to increase in the number of vehicles everyday. Time management will be the biggest challenge.



To make that possible this system supports usage of RFID cards and readers. The cards will be issued at the RTO office which contain all the information about the user and the registered vehicle.

The user has to just place the issued card on RFID reader, it reads the information of the user and the particular vehicle

from that card. The toll gates will only open if that vehicle is registered and the card has sufficient balance. The process is so quick and there will never be longer queues. Therefore use of RFID cards makes the process much faster. It has plenty of benefits because RFID cards are much cheaper and it ensures great accuracy without much delay. Therefore it will surely help in the betterment of the society.

## II. ARDUINO UNO

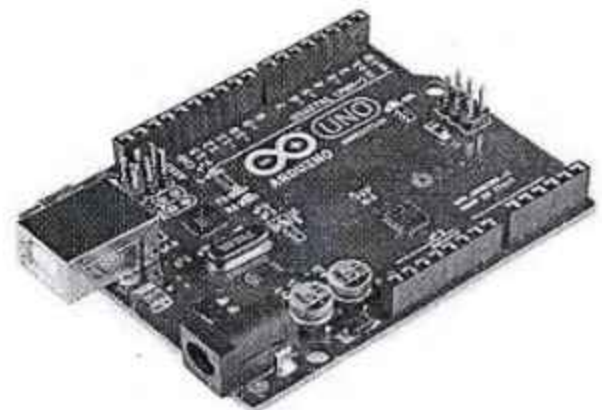

microcontroller. ATmega328P has 14 digital input/output pins. It has 6 analog input/output/pins. It can be programmed with the help of Arduino Integrated

# Fleet Management System Using IoT

Mr. S Christo Jain  
Dept. of Electronics and Communication  
Engineering  
K S Institute of Technology  
Bangalore, India  
christojain@ksit.edu.in

Karishma M  
Dept. of Electronics and Communication  
Engineering  
K S Institute of Technology  
Bangalore, India  
karishmamamjunath1303@gmail.com

Deeksha S N  
Dept. of Electronics and Communication  
Engineering  
K S Institute of Technology  
Bangalore, India  
deekshs459@gmail.com

Komala K V  
Dept. of Electronics and Communication  
Engineering  
K S Institute of Technology  
Bangalore, India  
komalakvni@gmail.com

Jyotsna B Upadhye  
Dept. of Electronics and Communication  
Engineering  
K S Institute of Technology  
Bangalore, India  
jyotsnaupadhye@gmail.com

**Abstract**— Resource Management play a vital role in daily life of fleet management. Particular some of the resources like fuel, driver behavior, theft maintenance, etc, are must be managed to avoid financial defeat. Fleet (Trucks or heavy Vehicle) Resource Management Systems can expose the average mileage and speed for a particular based on fuel. The IOT logistics that equipped GPS to track the fuel usage, driver's behavior, routes, speed, temperature, etc. for the fleet management. Location shared via GPS to the user interface can help truckers to find around the current areas. This work focuses on the key objective of the transportation management with minimum human resource so the management of the fleet with the development of IOT is employed in this work for the automatic fleet resource management, find driver behavior, health status of the vehicle.

**Keywords:** Fleet Automation, Fleet Health Statistics, IOT, Load Management, Live Tracking, Truck Monitoring.

## I. INTRODUCTION

Transportation as always been one of the key advancements of the humankind. it's impossible to contemplate today's world without vehicles. because the human population grows the amount of Transportation is one in every of the foremost advancements of the humankind. it's impossible to think about today's world without vehicles. because the human population grows the with economic development many of us are able to afford a vehicle of their own. because the number of vehicles grow, the probability of accidents occurring also increase by many folds. IOT technique is used to tackle the challenges and improve the activities and upswing the efficiency. The IOT is explained utilizing the information plumbing including internet protocol (IP), cloud computing and web administration. Fleet management using iot has an huge Impact on industrial automation and it makes us to utilise tablet PCs, PDAs, virtualized frameworks, and distributed storage of data etc. The smart fleet monitoring system using Internet Of Things (IOT) utilizes modest sensors to screen the status of trucks. The Arduino Uno used here could even be a method of microcontroller board supported ATmega328P (datasheet).

## II. LITERATURE SURVEY

S.KumarReddyMallidietal. [1] during this paper installation has been an element of evolving of humans. One cannot image the life

without vehicles. To accommodate the vast number of populations, the number of vehicles also has been increased rapidly. This also led to increased number of accidents. The accident-avoidance measures used now each day are all static and old. Also, there's no proper accident detection mechanism. This study proposes Smart Vehicle Monitoring System (SVMS) for early detection of accidents and also to forestall thefts. SVMS uses IOT technology to watch the vehicle continuously and also to access and control remotely. The IOT devices placed in vehicles is design Raspberry Pi (RPI) that's accustomed to sensors to detect accidents immediately. The RPI is additionally familiar with a camera to search out the severity of accident. SVMS uses machine learning based image classification model to detect the severity. When the accidents happen the SVMS detects it immediately and indicates the severity of the accident that has taken place. Next the system will immediately inform to the authorities about the accident. The SVMS also aware of GPS system. this can allow the SVMS to continuously keep track of vehicles location. This data is going to be wont to find the vehicles location during an accident or theft. The results of SVMS system were promising in terms of efficiently detecting the accidents, finding the severity of accident and also detecting the situation of car.

Nureni A. Yekini et al. [2] during this paper the microcontroller-based automobile tracking system with audio surveillance using GPS and GSM Module to produce another solution to security challenges experienced by car owner, and to develop a system which will track the situation of vehicles. Microcontroller Unit, GPS, and GSM unit is employed during this module. the look is an embedded application, which is able to continuously monitor a moving Vehicle and report the status of the Vehicle on demand. A PIC18F452 microcontroller is interfaced serially to a GSM Modem and GPS Receiver. A GSM modem is employed to send the position (Latitude and Longitude) of the vehicle from a far-off place. The GPS modem will continuously give the data telling the position of the vehicle. The GPS modem gives many parameters because the output, but only the information starting off is read and sent to the user's number. We use RS-232 protocol for serial communication between the modems and also the microcontroller. A serial driver IC is employed for converting TTL voltage levels to RS-232 voltage levels. When the request by user is shipped to the amount within the modem, the system automatically sends a return reply to the

# Arduino Based Smart Helmet with Automatic Rain Wiper

*SANTOSH HEGDE*  
Dept. of ECE  
K S Institute of technology  
Bangalore, INDIA

*RUTHVIK T N L*  
Dept. of ECE  
K S Institute of technology  
Bangalore, INDIA

*SUHAS M GOWDA*  
Dept. of ECE  
K S Institute of technology  
Bangalore, INDIA

*CHRISTO JAIN*  
Asst. Prof. Dept. of ECE  
K S Institute of technology  
Bangalore, INDIA

**Abstract**— In a country like India, where there is a drastic improvement in transportation technology and increase in total number of vehicles, road accidents are more frequent. Major impact due to accidents can be prevented by wearing a helmet as it acts as a headgear. This project has an intelligent system for two-wheeler accident prevention and also detection. This is a smart helmet that makes sure that the rider is wearing the helmet and is also non-alcoholic while riding. If any of the above conditions are true, ignition does not ON. Whenever an accident is detected, the emergency contacts are informed about the rider's location via GPS and GSM modules respectively. This project uniquely has a wiper which turns on when it detects any rain and keeps the rider's vision clear during rainy seasons. The ultimate goal of our project is to provide utmost safety to the rider with help of Smart Helmet.

**Keywords:** Helmet switch, Arduino UNO, smart helmet, automatic wiper, accident alert.

## I. INTRODUCTION

Road safety plays a major role in every country due to rapid increase in accidents. Around 30-35 people are dying in India everyday due to road accidents, The death toll has increased from 25% to 30% over the past 5 years. Most of these accidents occur due to the negligence of riding without helmet. Helmets are now required for all two-wheeler riders and it is also vital for pillion riders to wear one, but the discomfort caused due to helmets makes the rider not wear them and will finally result in fatal accidents. Though there are many rules and regulations implemented by the government, people are not following them and end up risking their lives. To avoid all such fatal incidents, we have come up with a system to make sure the bike's ignition will turn on only when the rider is wearing the helmet and also if he is non-alcoholic. If any of the above 2 conditions fail, the ignition won't turn on. With the help of this system, we would like to make commuting easier, safer and also mainly reduce the number of accidents taking place. In the present day, whenever an accident takes place, we are not in a position to provide immediate treatment to the victim, due to delay in medication, it may lead to death. So, all these situations can be prevented by immediately alerting the nearby ambulance or hospitals and emergency

contacts in case of any accident. By using GPS and GSM system, the location of the rider can be shared and immediate medication can be assured which will increase the chances of survival in case of fatal accidents. Also, during rainy situations, the vision of the rider will be mostly affected due to rains which may sometimes lead to accidents. So, to avoid such situations, this system consists of a Smart wiper which clears the rain droplets on the visor and makes sure that the rider's vision is clear and safe to ride.

## II. LITERATURE SURVEY

Nitin Agarwal has built a basic smart helmet which uses HT12E encoder and HT12D decoder IC's in order to transmit/receive the data from the helmet to the vehicle unit. An optical switch is used to detect if the rider is wearing a helmet, the motor will switch off if he/she isn't wearing a helmet.[1] PIC16F84a is used as a main microcontroller for controlling the vehicle, the helmet unit is consisting of a Force Sensing Resistor(FSR) for detection of helmet, BLDC motors are used for detection of speed and a buckle sensing system is used. All of these systems make sure that the helmet is worn, the buckle is strapped and the user does not go over the speed limit.[2] Sudarshan Vijayan has designed a helmet for the detection of alcohol content in the biker's breath and the ignition of the motor turned off with relay if user has more than 0.04 mg/L alcohol content. Here RF transmission and reception is used for the communication.[3] KeesariShravya has contributed in the project involving a smart Helmet which uses Solar panels to power the helmet. This project involves detecting the alcohol in riders breath, GPS, GSM, FSR , LCD display , MQ3 sensor for its working. Whenever an accident or whenever the user is drunk, an SMS is sent to his close ones to notify about the user's condition.[4]This project consists of an application for user interface, the project uses Strain gauge load sensors to detect overload of the bike. Accelerometers are used for detecting if the user is over speeding , IR sensor is used for detection of helmet on the user. All the data is fed to the database which then updates information to the Application. It mainly focuses on the user's safety and for relaying information to his family members.[5] This helmet

# Attendance System Based on Fingerprint

Sai priya.T.S  
Department of ECE  
KS Institute of Technology  
Bengaluru,INDIA  
[sai.som2001@gmail.com](mailto:sai.som2001@gmail.com)

Tejashwini.p.v  
Department ECE  
KS Institute of Technology  
Bengaluru,INDIA  
[tejashwinipatel3@gmail.com](mailto:tejashwinipatel3@gmail.com)

S. Christo Jain  
Assistant Professor Department of ECE,  
KS Institute of technology  
Bengaluru, INDIA  
[s.christojain@gmail.com](mailto:s.christojain@gmail.com)

Swahti .U  
Department of ECE  
KS Institute of technology  
Bengaluru,INDIA  
[swathibandalkar27@gmail.com](mailto:swathibandalkar27@gmail.com)

*Abstract- activity designed to determine the value of student management system within an organization using biometric (fingerprints). This study will enable any institutions /organizations to sign the presence of any student/employee in advance with data on fingerprint will be a department that will be considered a signature. A challenging part of the program is how to manage a website and website structures and the minds of its business. [1]*

*Keywords-Fingerprint sensor, biometrics attendance system, ARDUINO UNO, LCD DISPLY, ADAFRUIT Software, ARDUINO IDE, Keypad.*

## INTRODUCTION

Being present is one of the most important tasks you should have done in the organization as it will show how committed you are individuals who belong in that organization. It is important because to the reader it shows how many students speeches learn in all subject's ,and be given certain marks by visiting the curriculum and staff an important parameter for calculating income. [1]

Currently, students are being relocated to more facilities is a teacher in paper attendance books. There may be accuracy in data line method is not available for review because paper registers are available not loaded in the middle program, the time taken for the data collection reduces effective speaking time and deception student visits. Some universities also use the wall RFID swipe card systems in start. RFID the wireless technology use electrical communication between RFID reader and RFID tag. Although it is better than a paper base attendance system, RFID based systems also have some problems as the system is complex, expensive and out of school thus the card can swipe other student. [2]

There are few travel plans currently in use from phone number to using signatures and facial expressions acquisition of fingerprints. They all have their own gooda will. But a good arrival should be easy to use, it should Have been unique brand, it should be safe and very cheap in comparison. With this in mind the project is already underway biometrics to exist.

Biometrics includes the physical and biological use features such as fingerprints, iris, retina, distinct recognition of palm nerves individual and therefore full verification methods. This project was done using a fingerprint scanner to reduce module cost. It is also important that the project lasts a long time, confirmed by the use of fingerprints a scanner with excellent sensory health, reliability, accuracy and a quick response.

## ILMETHODOLOGY

The proposed system uses biometrics (fingerprints) for making existence that eliminates representative and personal problems completely wrong. It also uses data acquisition when preserved memory is extracted from the website easy to manage and save records compared to the sheets of paper. Copies of these information sites can be made to confirm this all although the website is corrupted or deleted by a person. The errors still exist to backup. As it uses fingerprints which also deletes the need to take calls and so on and also save time. All of the professors fingerprints are kept in order automatically you come to known what the conversation is going on again memory is classified in such a way the teacher can mark it attendees and transfer the module to another teacher and still the presence of his speech is maintained as a visit to the next teacher is kept in separate memory. And the option to clear memory Is the password secured therefore only teacher can erase recorded background data download it from the computer.

# Fingerprint Based Door Lock using Arduino

RAMYA SREE R  
Electronics  
Communication  
Engineering  
K S Institute of technology  
Bangalore, India  
ramyasree24112000@gmail.com

VANDANA G  
Electronics & Communication  
Engineering  
K S Institute of technology  
Bangalore, India  
vandu12312@gmail.com

SALEEM.S. TEVARAMANI  
Electronics & Communication  
Engineering  
K S Institute of technology  
Bangalore, India  
saleemstevaramani@ksit.edu.in

**Abstract**— In this paper, a fingerprint door lock system using Arduino will be developed. Security has been a serious issue nowadays when we are away from our family. So, this introduces the security solution to the problem. It can be used at offices, homes, hospitals, and other places. private sectors. When no one is present, an unauthorized person may attempt to break the door. It uses a microcontroller, which is an open-source instrument, used to write and upload computer code to the physical board.

**Keywords**— Fingerprint, Door, Lock, Arduino, Security.

## I. INTRODUCTION

Nowadays, homes, banks, sectors, and shops all need security for safety purposes. To provide security, a fingerprint door lock system has been introduced. This produces high security when an unauthorized person tries to unlock it. Security . It is one of the most common issues we face in our daily lives. Typically, standard doors can be outfitted with locks that can be broken with an alternate key. Alternatives to this system can be found, like the password or pattern system. In the lock, which again has the possibility of getting exposed and opening the door lock. Combining door locks with biometrics can be a solution to these problems. The disadvantage of using traditional door locks is that when a homeowner loses the key, they must wait a long time until the technician comes, or they must break the door. To overcome all these problems in traditional door locks, we use finger systems, which provide more security. The systems are easy to use and access.

## II. LITERATURE SURVEY

[1]In this paper titled, "Arduino Based Smart Fingerprint Authentication System" The system deals with fingerprint, RFID card, pin and password by unlocking

the system. These systems doesn't have high security. The actual system used in the market has fingerprint authentication, pin used to access the devices.

[2]In this paper titled, "Fingerprint based door lock using Arduino" The system deals with security issues that we face every day. It uses biometric locks it includes fingerprints and iris which increases the security level.

[3]In this paper titled "Intelligent fingerprint lock based on STM32" this system has high accuracy if the fingerprint is clean. By transmitting the alarm information to the upper computer real time monitoring is realized, so that security system will be improved. [4]In this paper titled, "Fingerprint based security system" in this system the security in which the register owners fingerprint is scanned into Arduino using fingerprint scanner. For this system 5v supply has been given, when we put fingerprint sensor after and not as an independent document. Please do not revise any of the current designations. registering, the lock will be unlocked in process solenoid lock will be locked.

## III. METHODOLOGY

The first step is to scan our fingerprints. The scanned fingerprint, if it matches with the fingerprint that is stored in the system, unlocks the door hook with the help of a relay.

If the scanned fingerprint does not match with the fingerprint stored in the system, then the unauthorized person will not be able to enter. If the unauthorized person tries to access the door more than 3 times, to carry out these functionalities, the following components are used:

Along with hardware, we are using software to program the functioning of the hardware devices.

Note: Before we do any process, we must store fingerprints using the Arduino IDE.



# Smart Assistant for Visually Impaired People

Saleem S Tevaramani  
Assistant Professor Dept of ECE  
K.S. Institute of Technology  
Bangalore, India  
[saleemstevaramani@gmail.com](mailto:saleemstevaramani@gmail.com)

Vivek Gowda J  
Dept. of ECE  
K.S. Institute of Technology  
Bangalore, India  
[vivekverrarasa@gmail.com](mailto:vivekverrarasa@gmail.com)

Vijayshankar K  
Dept. of ECE  
K.S. Institute of Technology  
Bangalore, India  
[vijayvishwa34@gmail.com](mailto:vijayvishwa34@gmail.com)

Akash C G  
Dept. of ECE  
K.S. Institute of Technology  
Bangalore, India  
[akashguravannavar@gmail.com](mailto:akashguravannavar@gmail.com)

Vinay S  
Dept. of ECE  
K.S. Institute of Technology  
Bangalore, India  
[VinayS020301@gmail.com](mailto:VinayS020301@gmail.com)

## ABSTRACT

This paper describes the goal of developing a system that can support the daily lives of people with disabilities. The visually impaired people face many challenges. In most cases, they need constant support in all situations, especially in their daily activities. One of the biggest challenges is the difficulty of moving from one place to another without the help of others. In addition, it is difficult to recognize people and obstacles. To overcome this condition, proposed "optical character recognition". The proposed system is equipped with an obstacle detection sensor that displays obstacles to the visually impaired. A camera that connects to proposed system that uses Optical Character Recognition (OCR) to convert images to text. The read data is converted to speech using the text to speech synthesizer. The device combines a variety of available technologies into a single multipurpose device that can be used by the visually impaired. This paper describes the challenges associated with designing such systems and devices.

**Key Phrases:** Camera, GTTS, Optical Character Recognition, Sensors, Visually Impaired Person.

## I. INTRODUCTION

Many have lost their eyesight, and some have been blind since childhood. According to the World Health Organization (WHO), there are 284 million visually impaired people worldwide. Many types of investigations have been conducted to solve these problems. Previously, Louis Braille was a French educator and inventor of Braille. This is a main script and users need to learn it before they can understand it. Some of them can only be accessed by understanding Braille. Computers and other technologies are rarely available, but voice formatted information may be required. The Science Library is the contact point for information for doctoral and graduate students. The visually impaired also need all of the above resources. Only Braille books were available in Indian libraries decades ago to help and guide the visually impaired. Today, several technologies are being developed based on the latest technologies for the visually impaired. Moderators are introduced based on OCR, blind obstacles, and more. However, these techniques are not sufficient to overcome all the problems faced by the visually impaired.

People with visual impairments find it difficult to cope with their daily lives without help. Many developments and designs to date have found drawbacks such as the use of applications, blind sticks, portable devices, etc. They are not effective. That's why we are introducing new technologies based on the limitations of existing, and more efficient and cost effective project. The proposed system also provides excellent support for people with disabilities in outdoor environments.

This document designs, develops, and implements a system that helps visually impaired people analyze live footage in front of them and convert it into audio to recognize and understand human emotions. This works with the help of a camera attached to the proposed system.

They can walk more confidently because our system recognizes directions on the road and follows voice-based instructions to reach the correct destination. To achieve this, Optical Character Recognition (OCR) (used to convert different types of documents such as OCR, captured images, etc. into editable and searchable data), Text-to-speech synthesis (TTS), and Google Text-to-speech synthesis (GTTS). Numerous frameworks (used for language translation) integrated into a system that allows users to take pictures and hear the text in the pictures.

## II. LITERATURE SURVEY

X. Chen and A. L. Yuille et al. [1] Recognizing when reading text in natural scenes suggests algorithm for recognizing and reading text in natural images. City scene. This text contains patterned shapes such as road signs, hospital signs, bus numbers, and other shapes such as store signs, house numbers, and signs. In this article, we will select this set of features based on the principles of information features. You can get a proportional test of the log-ability by calculating the general probability distribution of the above and subsequent text feature responses to the weak classifier.

# Solar and Wind Powered UPS System

Abhishek V  
Dept. of Electronics and  
Communication  
K. S. Institute of  
Technology  
Bengaluru, India  
vabhishek9876@gmail.com

Manoj G S  
Dept. of Electronics and  
Communication  
K. S. Institute of  
Technology  
Bengaluru, India  
manoj.gs@gmail.com

Akash R  
Dept. of Electronics and  
Communication  
K. S. Institute of  
Technology  
Bengaluru, India  
nameisakash34@gmail.com

Saleem S Tevaramani  
Assistant Professor Dept. of  
Electronics and  
Communication  
K. S. Institute of  
Technology  
Bengaluru, India  
saleemstevaramani@gmail.com

Chinnapu Charan Teja  
reddy  
Dept. of Electronics and  
Communication  
K. S. Institute of  
Technology  
Bengaluru, India  
ccharantejareddy@gmail.com

**Abstract**— As the demand for electricity is rising every single day, this demand would be hard to meet with the regular production of electricity by using non renewable resources of energy. Hence making use of some renewable resources of energy like solar energy and wind energy can be of great help to meet the demand of uninterrupted power supply. Solar energy is a low-cost source of electricity and instead of using the generators, solar panel can convert direct sun rays to electricity. The project designed focuses on the different techniques that can be inculcated in order to enhance the efficiency of the solar panel, which in turn reduces the number of solar panels needed for installation and thereby reducing the installation cost.

**Keywords**—renewable resources of energy, solar energy, wind energy, uninterrupted power supply

## I. INTRODUCTION

As the range of applications for solar energy increases, so does the need for improved materials and methods used to harness this power source. To minimize the issue of unreliable supply of electricity, the proposed design utilizes a UPS system which is charged by the renewable resources of energy like solar and wind energy. But these resources can be unpredictable in nature. So, using only solar energy may not be efficient on cloudy days as it would have been on a sunny day and in the same way using only wind energy may not be much efficient on non windy days.

Perhaps, the integration of these two renewable resources into an optimum combination would be an efficient method to continuously charge the batteries of the ups. There are several factors that affect the efficiency of the collection process. Major influences on overall efficiency include solar cell efficiency, intensity of source radiation and storage techniques. The materials used in solar cell manufacturing limit the efficiency of a solar cell. This makes it particularly difficult to make considerable improvements in the performance of the cell, and

hence restricts the efficiency of the overall collection process.

Conventional solar panel, fixed with a certain angle, limits their area of exposure from sun due to rotation of Earth. Therefore, the most attainable method of improving the performance of solar power collection is to increase the mean intensity of radiation received from the source. In pursuing to get the maximum energy converted from the sun, an automatic system is required which should be capable to constantly rotate the solar panel. The automatic solar tracking system solves this problem. Microcontroller based I/O configuration is used as the hardware along with the comparison unit of LDR for detecting the ray strength and shift the panel towards the maximum output from the sun. This system is also connected with cleaning wiper, which cleans the panel in suitable rotation with the help of the DC motor. The control of the cleaning system depends on the microcontroller with its automatic mode of function. This cleaning feature which helps to increase the efficiency of the solar power. The solar tracker, a device that keeps panel in an optimum position perpendicularly to the solar radiation during daylight hours, can increase the collected energy from the sun.

## II. LITERATURE SURVEY

Nishant Jha et al [1] have proposed a dual energy generation system for integrated grids to prevent the wastage of energy which is harnessed by making use of hybrid systems, which are a combination of solar photovoltaic and wind energy systems. By considering the factors such as wind energy, the tilt angle of PV array optimization, and inverter optimization the reliability and stability of the system has been improved. Based on this an optimal grid system configuration is designed. The cost analysis proved that the installation of the suggested system is much more cost efficient than other systems.

Vignesh M et al [2] have proposed a standalone UPS system which makes use of a solar tracking

# Sign Language Translator: Connecting People

Aruna Rao B. P  
Assistant Professor, ECE Dept.,  
K. S. Institute of Technology,  
Bangalore, India  
arunaraobagre@gmail.com

Sujay R  
BE Student, ECE Dept.,  
K. S. Institute of Technology,  
Bangalore, India  
sujayrudresh1234@gmail.com

Christo Jain S  
Assistant Professor, ECE Dept.,  
K. S. Institute of Technology,  
Bangalore, India  
s.christojain@gmail.com

Somashekar M  
BE Student, ECE Dept.,  
K. S. Institute of Technology,  
Bangalore, India  
shekarmeda342@gmail.com

**Abstract**— Communication provides interaction between people to exchange their thoughts, emotions and ideas. The Deaf community suffers greatly from community interaction. Sign language is one of the ways through which hearing and visually impaired people communicate with others. There is a need for a system that can convert sign language into an easy-to-understand form so that people who are unaware of sign language can use it to interact with others. The purpose of this work is to provide a real-time system that can convert sign language into text. This article introduces a deep learning approach that allows us to classify characters using convolutional neural networks. We developed a classifier model using the Fingerspells which are based on the ASL convention using the Keras implementation of a convolutional neural network using python. In addition to this, we have developed a method in which the deaf and mute community could translate Sign Boards, Route maps, Menus and any image containing digital text to their preferred language along with an audio output both in English and the preferred language as well as the Fingerspell implementation. This approach uses Google Text to Speech API and Py-Tesseract OCR.

**Keywords**—Machine Learning, Keras, Convolutional Neural Network, Sign Language

## Introduction

Sign language is one of the basic means of communication for people with hearing or voice disabilities. These people find it difficult to communicate with others in their daily lives. We aim to develop a system that tries to eradicate this communication barrier. Sign language requires using our hands to create shapes and movements, along with certain specific facial expressions. Therefore, the recognition system must recognize the signer's head and hand poses or hand movements, facial expressions, and sometimes even body postures.

American Sign Language is one of the widely used dialects throughout the world. It uses a single hand for fingerspells and most of them are static,

while Indian Sign Language and other languages use two hands and Dynamic Fingerspells. The only obstacle that hearing-impaired and mute people have in common is communication-related, and they cannot use spoken language, so the only way they can communicate is through sign language. Gestures or Dynamic Fingerspells are the non-verbally exchanged messages and these gestures are understood with Vision. This non-verbal communication that deaf and mute people use is called Sign Language

The Deaf and Mute People face a lot of difficulty in their day-to-day lives. It becomes much harder for them to travel to places with different native languages. Normally all the Sign Languages are based on the English Alphabet and hence it becomes more challenging for them to communicate with the natives as they might not be knowing English.

An effective hand-based interaction method that involves recognition of hand gestures using Machine Learning to predict letters in the form of text/video conveying what the user is trying to express. The steps include pre-processing images extracted from the video feed, converting the user's hand and eliminating the background and comparing the hand image with the dataset using the model leading to gesture recognition. The predicted text can be converted to speech or displayed on a monitor. We will be using OpenCV to capture and pre-process images required to create the dataset, and TensorFlow to train and predict using CNN (Convolutional Neural Network) model.

The Deaf and Mute People face a lot of difficulty in their day to day lives. It becomes even more harder for them to travel to places with different native language. Normally all the Sign Languages are based on the English Alphabet and hence it becomes more challenging for the Deaf and Mute to communicate with the natives as they might not be knowing English.

We came up with a solution which might help people facing these situations to some extent. We propose a method using which the public Sign boards, Route Maps, Restaurant

# Real Time Traffic Monitoring

Shiva Shankar B  
Dept. of ECE  
K S I T  
Bangalore, India  
shivashankarb45678@gmail.com

N Naga Omkar  
Dept. of ECE  
K S I T  
Bangalore, India  
nagaomkar23@gmail.com

C A Sushma  
Dept. of ECE  
K S I T  
Bangalore, India  
sushmaca306@gmail.com

Mrs. Pooja S  
Dept. of ECE  
K S I T  
Bangalore, India  
poojas@ksit.edu.in

Rithvik P,  
Dept. of ECE  
K S I T  
Bangalore, India  
rithvikprabhakar@gmail.com

**Abstract**—The world population is increasing every day which in turn increases vehicular travel density that leads to congestion problem. Traffic congestion is the main reason for critical challenges and problems in the most populated cities. When traffic increases it results in wastage of a lot of time and fuel. Which in turn results in people missing opportunities, lose their time and get very frustrated. Traffic density is highly dependent on unpredictable situations such as accidents, constructional activities and vehicle breakdown. The above problems can be solved by a traffic control system which continuously senses and adjusts traffic lights time according to the actual traffic density which is called an Intelligent Traffic control System. The Intelligent Traffic Control System reduces the operational costs, congestion and provides alternate roads to drivers and increases capacity of infrastructure.

**Keywords:** *Intelligent, Traffic, Control, Alternate Route, System.*

## I. INTRODUCTION

Traffic examination has main aim to optimize traffic flow of drivers, citizens and goods which is the main reason of trouble especially when there is emergency case at traffic light junction which is always busy with many vehicles. But there are certain restrictions in handling intelligent traffic control systems. The Density Based Signal system in Traffic System has a main aim to solve traffic congestion problems that many citizens face and is a big problem in most of the cities. This approach proposed here increases road safety even while the traffic police are absent and gets their attention to those travelers who break the law. Traffic is managed in a circular loop which takes in the inputs on real time basis. NODE MCU is equipped with ESP Wi-Fi module and it collects and transfer all the data and information from the sensors and the data is made available at every local server that is setup and will receive the data from NODE MCU. The signals are very helpful at increasing the road safety and traffic maintaining capacity at most junctions. These will function without any help from timers and are connected to a computer controlled system which operates at a few junctions.

## II. LITERATURE SURVEY

W. Wen et al. [1] this system proposes a dynamic and automated signal control systems which develops simulation models that assists in system design. Here this system takes the average of departure time and arrival time which is physically observed at each intersection. The traffic congestion in many big cities can be solved by controlling the speed and duration limit of the traffic light. In most modern cities in countries, traffic congestion causes many challenges. For travelers and drivers, lost opportunities, traffic means lost time, and frustration and for employers, it is lost employee productivity, delayed deliveries, trading opportunities and increased costs. By solving the traffic problem, it is possible to physically build new facilities and policies and also to build an information technology transportation management system. If the road infrastructure is improved, the problem of traffic congestion cannot be solved. In fact in some cases, building new roads would further increase congestion by increasing the demand for vehicle traffic

K.R. Shruthi et al. [2] the system proposed here efficiently uses and manages traffic light control. An adaptive traffic control system that is based on a new traffic infrastructure that has a wireless sensor network (WSN). These dynamically adapt to traffic conditions at most single and multiple intersections. This system uses an intelligent signal control system and has new methods for detection of vehicle and dynamic signal manipulation. The project also manages traffic at multiple intersections and associates with international standards for traffic light operation. The central monitoring station monitors all access nodes.

Yousaf Saeed et al. [3] the system proposed here presents a task of a fuzzy logic application for a multi-agent based autonomous signal control system which uses wireless sensors to overcome the problems of speed, accidents, traffic irregularities and congestion. This agent-based approach provides a solution by minimizing vehicle traffic. In particular, emergency vehicles that uses fuzzy logic control in the normally occurring emergency situations. The information and data from the two traffic signals are used to calculate the effectiveness of this approach.

# Automatic Gas Leakage Detection and Regulation System

VISHNURAATA Y  
Dept. of ECE,  
K S institute of technology  
Bengaluru, INDIA  
vishnuraata@gmail.com

SRIRAM  
Dept. of ECE,  
K S institute of technology  
Bengaluru, INDIA  
raama10sach@gmail.com

SHREYAS V BHARADWAJ  
Dept. of ECE,  
K S institute of technology  
Bengaluru, INDIA  
bharadwajshreyasv@gmail.com

SRINIVAS S  
Dept. of ECE,  
K S institute of Technology  
Bengaluru, INDIA  
srinivas.s2001@gmail.com

POOJA S  
Asst. Prof. Dept. of ECE,  
K S institute of technology  
Bengaluru, INDIA  
poojas@ksit.edu.in

**Abstract**— India is a vast country with a huge population, which is developing at a great pace. Thousands of new gas connections are being installed each day, which also increases the risk of fatal accidents caused by gas leakage. Such accidents cost us innocent lives. The motto of this paper is to find a cost effective and efficient solution to this problem.

**Keywords**—gas leakage, GSM, servo, regulator, sensor

## I. INTRODUCTION

In India, the LPG gas connections have raised from 142 million in 2014 to 291.1 million till now. However, the regular enhancement of these connections goes with the hazardous leakages leading into fatal accidents.

For example, the gas leakage took at least 250-270 lives in the financial year 2017-2018 and around 100 lives in early 6 months of 2019-2020. The Indian parliament's panel of natural gas and petroleum deeply expressed its agony and concerned to minimize these accidents. For this purpose, panel summoned their LPG marketing companies. The OMC (Oil Marketing companies) like Indane, Hindustan petroleum, Bharat petroleum have reported prime reason for the accident was 'safe usage aware lessness among the new consumers'. Though some safety measures are taken by the OMC's accordingly, much need to be done in the profound manner. The oil companies inspected accident places and they found two reasons

- The gas leakage between cylinder and cooking stove
- Gas leakage directly from the burner due to lack of negligence.

In such cases the flow of LPG needs to be stopped right at the cylinders, this remedial precaution is laborious. Keeping all the above facts we, young mind thought to come out with an automatic electronic remedy to nullify these above fatal accidents. At present we're with the instrument which is also the project specified for our penultimate year of our studies.

## II. LITERATURE SURVEY

In this paper along with the gas leakage detection the real time sensing of gas is also done. As soon as the gas leakage is detected the gas sensor sends a signal to the Arduino. If the gas leakage is detected the sensor will give the output as 1 and if it's not detected it will give the output as 0 [1]. Gas leakage cause many catastrophic accidents each year taking many lives. This paper addresses this problem. A MQ9 gas sensor is employed, which can accurately detect combustible gases and even smoke. Other sensors like MQ6 and MQ2 are also used to increase its detection spectrum. A Wi-Fi transceiver is used that supports interfacing of multiple sensors. DC motor is employed to shut off the gas valve. An LCD is used to display the alert message [2]. An important requirement that should be accomplished in every society is to make houses safer and sustainable. Nowadays, the accidents due to gas leakages and fires at homes are increasing day by day. The existing prevention systems are widely available but they fail to interact with the existing Machine-2-Machine(M2M) home networks and with the outside networks. This paper includes the design of a system to integrate the gas leakage and the fire detection as well using low-cost devices. Then, through machine learning approach, the changes in the air state are determined for early prediction of the incidents. This system shall ensure safety and protection at homes and industries [3]. In this paper, a system is designed in order to detect the gas leakages continuously at homes or industries. Once the gas leakage occurs, the information will be sent to the web browser via IoT Communication. MQ6 gas sensor is used which is highly sensitive to flammable gases and acts as an input to the Arduino Microcontroller. This MQ6 sensor helps in sending a signal to the Microcontroller. LED, Buzzer and IoT module (ESP8266) act as outputs to the Microcontroller. The WI-FI module is implemented to

# Attendance monitoring and access control system

AISHWARYA R

Electronics and Communication  
engineering  
K S Institute of technology  
Bangalore,India  
raishwaryahr@gmail.com

SUPRIYA S

Electronics and Communication  
engineering  
K S Institute of technology  
Bangalore,India  
supriyababu321@gmail.com

SUSHMITHA R

Electronics and Communication  
engineering  
K S Institute of technology  
Bangalore,India  
sush2552000@gmail.com

VANDANA K

Electronics and Communication  
engineering  
K S Institute of technology  
Bangalore,India  
vandana.k54320@gmail.com

BHARGAVI ANANTH

Electronics and Communication  
engineering  
K S Institute of technology  
Bangalore,India  
bhargavi\_ananth@hotmail.com

**Abstract:** On a daily basis, many organizations and institutions do not efficiently use time for documenting attendance and providing access to each member. When it comes to ensuring high security to places like educational institutions, the usage of an attendance monitoring and access control system is essential. Physical control systems are very important for the protection of infrastructure systems, since they allow timely access, attendance tracking, and the security of critical regions. This approach concentrates on a limited number of feasible strategies. The proposed work will suggest a suitable, accessible, dependable, efficient, and cost-effective attendance and access control system. Based on the level of security, the proposed approach comprises of two separate ways for attendance monitoring and access control system. RFID tags are utilized for applications with a primary degree of security, and fingerprint-based biometrics are employed for applications with an intermediate level of security. RFID tags are utilized to offer authenticated access as well as timely database recording of user information. Biometrics are mostly used to track student attendance, and the data is stored using IoT. User access and attendance information can be viewed at any time and from any location.

**Keywords:** Access control, Attendance monitoring, Authentication, Authorization, Biometric, Database, IoT, RFID tags

## I. INTRODUCTION

We are becoming increasingly reliant on a wide range of digital applications as the digital world continues to grow. In many cases, the primary priority is that access to these applications be secure and verified. [6] In educational institutions, monitoring attendance and allowing access to authorised users is critical, and the development of such systems is exploding, as shown in Figure 1a.

Only authorized users should have access to a certain location or area to which they have been permitted access. Because of the interconnected challenges of impersonation, spoofing, proxy, phishing, and information theft, proper person-verification and authentication solutions, as well as access attendance monitoring, are becoming increasingly important. For large groups of employees or students, biometric technology, which uses fingerprint verification to verify an individual, is the most practical and reliable technique for recording attendance and giving access.

[6] As illustrated in Figure 1b, fingerprint verification is the most widely acknowledged, recognized, and rising biometric technology, followed by RFID cards, another promising technology prioritized after biometrics.



Fig. 1.1: Usage of access control systems in various applications

# RFID Library Book Access System Using 8051 Microcontroller

Anjali Y J

Electronics and Communication Engineering  
K S Institute of Technology  
Bengaluru, India  
anjuyj@gmail.com

Aishwarya Basavaraja Kembavi

Electronics and Communication Engineering  
K S Institute of Technology  
Bengaluru, India  
aishu9722@gmail.com

Pooja SP

Electronics and Communication Engineering  
K S Institute of Technology  
Bengaluru, India  
psp922001@gmail.com

Archana Yadav M

Electronics and Communication Engineering  
K S Institute of Technology  
Bengaluru, India  
marchanayadav1205@gmail.com

Bhargavi

Electronics and Communication Engineering  
K S Institute of Technology  
Bengaluru, India  
bhargaviananth1230@gmail.com

## ABSTRACT

RFID is a combination of microchip technology and radio - frequency based technology. In this project we make use of 8051 microcontroller for processing. This technology mainly aimed on reducing the time spent on scanning barcode by staff members as well as students. RFID helps us to speed up the borrowing and returning process of books and also function as an anti-theft system. RFID tag will be put inside the book for easy identification. Whereas while borrowing, the user tap the RFID tag of the book and details of the borrower is saved and book is issued, and due date is given to the borrower. While returning, the RFID tag is again scanned, checks the borrower details and also any delay in due date.

*Keywords—RFID, RFID tag, 8051 microcontroller*

## I. INTRODUCTION

RFID is a wireless technology that is used to develop the access control system. In this project, the main parts of an RFID system are RFID tag read by the reader and RFID reader operating at a frequency of 125KHz also we can develop library automation system, which can track the books, whether they are issued in the library, so that library user will get the information. RFID tags are unlike the bar code. These tags can control various information such as book number, accession number, author information etc. The data on the tag includes the unique identification number so we can scan the number, which is in book and shows the details of books. Here, the software using a microcontroller that controls all the hardware components. This software plays an important role in the system. The main objective of a system is to unique identify and to make security for a person. It provides an overall view with detailed discussion of the system. Library systems also transformed into e-library, digital library according to the evolution of the technology.

## II. LITERATURE SURVEY.

B. Gnanaprakash and his team introduce the 8051 Microcontroller and Embedded systems for implementing the RFID applications. The main objective is to provide security in an organization by allowing only the authorized personnel to access the secure area [1]. K. SrinivasaRavi, G and his team

worked on RFID based security system and they used to provide security for the industries, companies etc. They also increase the use of biometric technologies for security and also significant advantage of non-line-of-sight nature of the technology [3]. Umar Farooq and his team develop the RFID security and access control system and they worked on access control system use in hostels inside the Punjab university premises. The system access control task by processing the information and also accomplishes the security from sub-controllers [2]. Deepthy R Nair and his team works on smart library management system that is to realize a visual book search and management system so, that it solves the problem of existing bar code technology [4]. Hee-Kyung moon and his team build a generally on digital library is to electronically digitized information resources such as-formats , providing services by establishing a large scale electronic information and also it is used for various media[6]. Neha Pandey and his team are implemented RFID system is security based system. It is able to search tagged book in the library and it was successfully developed and also they secure well write barcode for 2 microcontroller has to communicate with each other [7]. N. kalyani and his team worked on RFID base secured access system implemented on Microcontroller. RFID system contains reader device and a transponder. Users don't know how to use card access system like door controls to buildings using RFID readers and RFID tags [8]. Tara Zimmerman and her team as build the implications of the smart libraries. They want to move towards generation smart libraries it includes information services, RFID technology growth [9].

## III. METHADODOLOGY

The purpose of this project is to access the library books with low cost using microcontroller. This will helps us to borrow the books by swiping the RFID card which contains access number. In this project includes 8051 microcontroller, RFID tags, EM-18 reader module and LCD display. Here, RFIG tag is input to the EM-18 RFID reader that carries the details of the book through microcontroller and it displays on LCD.

# Wireless Notice Board Using GSM

Keerthana A  
Dept. of ECE  
Assistant professor  
K.S. Institute of Technology  
Bangalore, India  
anandarajukeerthana@gmail.com

Gowri S N  
Dept. of ECE  
K.S. Institute of Technology  
Bangalore, India  
gowrinadiger@gmail.com

Amruta  
Dept. of ECE  
K.S. Institute of Technology  
Bangalore, India  
amruthapattanashetty@gmail.com

Vaishnavi Kanamarlapudi  
Dept. of ECE  
K.S. Institute of Technology  
Bangalore, India  
vyshu2009@gmail.com

## ABSTRACT

This paper deals with idea of wireless notice board using GSM technology. The SIM800L GSM modem is used for the wireless communication. In this the messages are sent to the GSM through the mobile phone in the text format, and that messages are extracted by the microcontroller 8051(AT89S52) where it is the heart of the model and the message displayed on LCD display board. In 8051 microcontroller the programming language used is C language to write the program we are using Keil u vision software and for simulation we are using proteus software where we can see the end result of the circuit diagram.

The model of notice board as low maintenance and low cost. And it doesn't undergo tedious process that is followed by the conventional notice board. It can be used in small institution to large organization, it is more useful in crowded areas, railways, etc... **\*CRITICAL:**

**Keywords—GSM modem, LCD display board, 8051 microcontroller, Keil u vision, proteus.**

## INTRODUCTION

Now a days smart phones are playing vital role in our daily life. So, we came with idea of making the wireless notice board using GSM. This helps us to replace the old method that involves pinning up notices and that leads to wastage of paper. And this old traditional method also has a disadvantage of dependency on a person. To overcome the above mentioned issues we thought of displaying of the data on LCD (liquid crystal display) and LED(light emitting diode) can be used for the display purpose. By the wireless GSM technology we can also reduce the deforestation, global warming also.

It can also be used for advertisements and big shops and the shopping complexes use digital display now which are convenient for the customers. And they can also be used in schools, colleges and small to large organizations, railways, traffic signals.

In this paper with the aim to increase the usability of electronic and wireless notice board, it deals with wireless module used is GSM and the microcontroller used is 8051. The 8051 is interfaced with GSM and the

LCD display. The GSM modem is available in over 219 countries and territories. GSM is known as Global System for Mobile communications, originally Group Special Mobile. The GSM is consisting of SIM(Subscriber Identity Module) to connect to mobile phone, which will send the message to the GSM and it refers to the wireless communication. And the microcontroller used is 8051-AT89S52 it belongs to the family of 8051 microcontroller. It is a 40 pin IC consists of 4 8-bit parallel ports and it is used to process and decode the information sent by the GSM. The LCD display used is 16x2 where 16 characters are displayed in single line. The text is displayed on the LCD display.

The agenda is to make life simple with the help of technology, this is one step to simplify real time noticing, and its efficient model and error occurrence is less, consumption of power is less and easy to operate, also notification can be delivered within seconds.

## I. LITERATURE SURVEY

[1]"GSM BASED WIRELESS ELECTRONIC NOTICE BOARD USING PIC18F2550 MICROCONTROLLER" BY ABIODUN, AJAYI, BELLO.

The Smart phones are playing vital role in human life. They are easy to use, promising and durable devices that help in performing day to day tasks. This message almost displayed immediately without any delay just by sending a SMS which is better and more reliable than the old traditional way of passing the message on notice board PIC18F2550 acts as the central processing unit for this project and connectivity applications that benefit from the availability of three serial ports: FS-USB, FC™ and SPI and an asynchronous serial port. PIC18F2550 which has both hardware and software capability.

It has some extra supporting hardware like +5volts power supply, Power on RESET, Clock generator and pull up resistors, and it also requires +5v for power the microcontroller and p10 dot matrix display, +4v GSM modem is used. When the power is on the LED start glows and waiting for message and microcontroller gets initialized than waiting for message, the message which



## DESIGN AND FABRICATION OF GYM EQUIPMENT FOR POWER GENERATION

Ashish Vilas Jadhav<sup>1</sup>, Akhiljith KS<sup>1</sup>, Bharath R<sup>1</sup>, Jagruth S<sup>1</sup>, Dr. Girish TR<sup>2</sup>

<sup>1</sup>Students, <sup>2</sup>Associate Professor  
Department of Mechanical Engineering,  
K S Institute of Technology, Bangalore-560109, Karnataka, India

### ABSTRACT

*This paper deals with alternate source of energy, since there is a scarcity of conventional energy resources now a days, there is a need for developing and usage of renewable energy resource. In this work an attempt has been made to convert the energy released by people when they are doing the work out. Here human acts as the power source and the gym equipment acts as both exercise equipment and source of power generation. Here reciprocating motion of the equipment is converted in to rotary motion using rack and pinion arrangement. Further the rotary motion is converted in to electrical energy by the use of alternators.*

Keywords: Source of energy, conventional, renewable, gym equipment, Rack and pinion.

### 1. INTRODUCTION

The renewable energy resource has becoming an progressive subject among the research and scientific community. The idea is to build an energy resource that can generate renewable source of energy from day to day activities. The novel work is intended to covert the mechanical energy into electrical energy from the gym equipment when people start doing the workouts. The converted electrical energy can be used to power lights, charging of cell phones and other small applications which require less power. Further these systems can be improved for large scale power generation with minimum cost and marketability. In this project provision has been made for the efficient and controlled power storage. The gym equipment is connected to dynamo motor which converts kinetic energy in to electrical energy. The converted electrical energy can be used to power the lamps, charging etc. Most of the fitness center equipped with treadmills, rowing machines, stationary bikes, pull up machine etc to burn calories. Power produced will be dissipated as heat energy. This heat energy if it is captured and used as an alternate source of energy will be good for environment and reduce the consumption electricity from the primary source. The process of capturing, converting and storing of this energy is called Energy Harvesting(EH). There are different methods available of converting in to electrical energy using gym equipment. The various gym equipment are Treadmill, pull up machine, bicycle etc.

#### 1.1 Tread Mill

Tread mill equipment are used both in gym and home. Tread mill consists of path like structure which rotates and shift, so that the person can walk and run like in out door. He can also set the speed according to his requirement and capacity. The burnt calories can also be converted in to electrical energy and even it has been implemented in many houses and gym centers. It can produce up to 95 Watts of power in average which can be used for many applications. Fig 1 shows the setup of tread mill in a gym.



FIGURE 1. Tread mill in a Gym

### 1.2 Pull up machine

Another very important equipment in gyms are pull up machines where people try to lift heavy loads when they do the exercise. These equipment are not widely used since power generation is relatively less as compared with other equipment. Power generation is done when the loads are lifted. Conversion of energy from mechanical to electrical is done by attaching rack and pinion arrangement or with sprocket. Fig 2 shows the gym pull up equipment.



FIGURE 2: Gym pull up equipment

### 1.3 Stationary bicycle

Stationary bicycles are one of the very important equipment in gyms. These bicycle are used for cardio vascular exercises for both men and woman. It is one of the best exercise for heart. These stationary bikes are coupled with electrical generator which is used in the gym are called eco bikes. The mechanical work i.e pedalling of the pedals in turn rotates the wheel attached to it, these wheel is connected to electrical generator. These types of bicycles are used in modern gyms. Fig 3 shows the stationary bicycle used in the gym.



FIGURE 3. Stationary bicycle used in gym

## 2. CONSTRUCTION

### 2.1 Energy conversion equipment for Gym machine

In this project an attempt has been made to design and fabricate electricity generation from pull up machine. We are expecting an output of 55 – 60 watts, this can be used lamps, an amplifier and an ipod charger. This system consists of many sub systems that will work collectively for the efficient production of electric power. The first sub assembly consists of elements which converts kinetic energy from pulling to generator. The second system consist of electrical generator, this sub system transfers rotational movement in to output AC voltage. The next sub system converts AC power to DC, This DC power is stored in batteries. The stored energy is sent to the inverter which converts 12V DC to 12V AC. By using step up transformer the 12V AC is stepped to 230V.

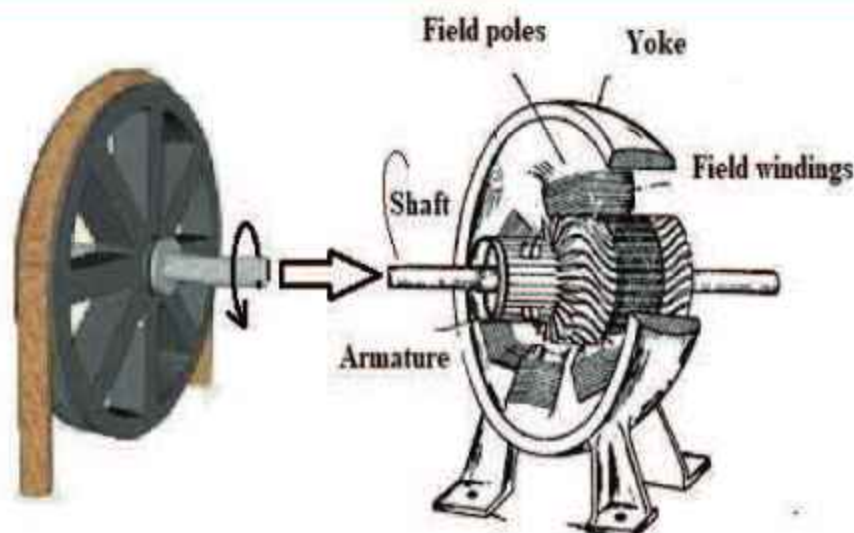

FIGURE 4. Output of pulley connected to alternator

### 3. METHODOLOGY

- Initially the frame of the body has been set up which contains the major components of the model. The frame has been taken from gym(not in use) which is converted to our requirement.
- Bearings are provided at proper position which carries the main shaft which is then supported in the frame. Pulleys are added(in between) to reduce the human effort.
- A wire rope is used to connect between the handle at one end and the other end is attached to dead weight through pulley.
- Dynamo along with pulley is also supported on the frame which is connected to driver pulley using rope.
- The electrical connections has been made which is connected to dynamo .
- The conversion of AC from the dynamo to DC is done using rectifier circuit.
- The output from the rectifier is connected to 12V battery where it is stored.
- When people start using the equipment for work out the lifting of weight causes the rotation of the main shaft which is then connected to dynamo which produces electricity and it is stored in batteries.

### 4. COMPONENTS USED AND ADVANTAGES AND DISADVANTAGES

The main components used in this project work includes frame, handle, Bearings, shafts, pulleys, dynamo, batteries and dead weights. Some of the advantages include less maintenance cost, avoids any fossil fuels, environment friendly, human fitness and electrical energy can be stored in batteries.

The major disadvantages include , as compared with bicycle or treadmill less power conversion, since more mechanical linkages there is a possibility of failure of the assembly, weight of the structure and sub structure is high so it is difficult to transport, additional attachments are more, the initial cost is bit high.

### 5. CONCLUSIONS AND SCOPE FOR FUTURE WORK CONCLUSIONS

- The design and fabrication of innovative gym equipment to convert kinetic energy in to electrical energy has been carried out.
- Storage of energy is very important and necessary part of the project work, it has been ensured the stability of the system is maintained. These models vary in complexity and accuracy and therefore the model chosen must match the application for which it is needed
- These systems can be incorporated in many places and if it is operated regularly it can convert sufficient amount of energy.
- It will be very helpful for the rural areas. In this day where the world is challenged to be more responsible in its sourcing of electrical power, the method of human power generation could be a solution that also helps mitigate the issue of obesity and overweight.

**Scope for Future Work**

- By having more number of dynamo more power can be converted in to electrical energy
- It can be adopted with variable gear ratio can be adopted
- It is possible to add fly wheel , speed control devices and voltage protection devices so that the system is full proof.
- If the system is installed in gym centres where more and more equipment's then more energy can be converted and power generation can be done in a large scale.

**REFERENCES**

- [1] M. Musharraf, Ifrah Saleem, Farhat Iqbal, Energy Generating Gymnasiums Machines for Renewable, Sustainable and Green Energy, International Research Journal of Engineering and Technology, Vol. 5(12), 2018, Pp. 153-160.
- [2] Roshan Ojha, Rahul Raj, Shaaravan Kumar, T.Hari prasadh, Naveen Kumar, KS Badarinarayan, Power generation by gym pull up, International Research Journal of Engineering and Technology, Vol. 5(6), 2016, Pp. 1297-1299.
- [3] Sourabh Borchate, Amit Gaikwad, Ajay Jadhav, Prasad Dhage, Design of Treadmill to Generate Electricity by using Mechanical Energy, International Conference on Ideas, Impact and Innovation in Mechanical Engineering, Vol. 5(6), 2017, Pp. 498-505.
- [4] Madhup Kumar, G S Mundada, Energy Harvesting from Gym Equipments, International Journal of Innovative Research in Electrical, Electronics, Instrumentation and Control Engineering, Vol. 5(7), 2017, Pp. 127-131.

## DESIGN AND DEVELOPMENT OF DUAL LUG NUT FOR TIGHTENING AND LOOSENING OF FOUR WHEELER TYRES

S.N.Naga Nithesh<sup>1</sup>, Nikhil Bharadwaj.V<sup>1</sup>, Suhas.J<sup>1</sup>, Akshay.R<sup>1</sup>, Girish T R<sup>2</sup>

<sup>1</sup> Students, <sup>2</sup> Associate Prof  
Department of Mechanical Engineering  
K.S. Institute of Technology Bangalore -560109

### ABSTRACT

The primary aim of the project is to design and fabricate a four-wheeler nut removing tool for tightening and removing of two nuts in single time. With the increase in use of cars on the road, the failure of tires has been increased considerably. Usually the cars are provided with spanner and a jack for the replacement of spare tires. Due to difficulties in maintaining uniform torque to remove nut and to save time. The main objective of the present work is to design and develop a single tool, which can be used for assembling and disassembling of nuts of tires in automobiles with minimum effort and time. Care has been taken for easy maintenance, storage and handling.

Keywords: Four-wheeler nut, uniform torque, automobiles and tires.

### 1. INTRODUCTION

In the modern world four wheeler has become the essentials. These four wheelers are provided with T-nut wrench and jack to replace the tires when there is a puncture or any other problem in the tires. For women or teen the usage of jacks is a hard task. Once any problem arises with the vehicle to replace the tires which takes lot of time and effort. Drivers should have basic knowledge of tire replacement procedure if such problem occurs. In order to change the tire, one requires minimal skills. Virtually every car has a tire replacement tools such as the L-shaped nut remover and jack supplied by the manufacturer accurate tensioning of a screw is necessary. It is a fact that a huge effort is required to open a single nut of a car wheel and it will become a tedious task to open the wheel in extreme atmospheric conditions. It also creates problem when there is an emergency situation. Here is the solution to the problem mentioned above by Adjustable Unified Wheel Opener, it is a special tool designed for opening a wheel with ease. It is so designed that it can open all the four nuts of a car wheel in one time. And the most desired achievement is that, the total effort and time needed in the process is very less. It can open and also refit the wheel with the same tool. This project is intended to develop a special tool to remove nuts from the tires with minimum time and effort for women and teens.

### 2. CONSTRUCTION

Nut lightener consists of gears of different sizes, the handle which will be rotated by the operator is connected to the smaller gear which is mounted on the bearings. The wheel nuts are connected to gear drives through extension rods. Slots are provided to make adjustments for opening of tires which are having different centre distances. Linear motion has been provided by keeping a support plate above the gears. The supporting and base plates are connected by bolts and nuts. The modelling of the assembly has been done in SOLID EDGE. The parametric modelling of the gear drives were also carried out. Fig 1 shows Multi-nut lightener and lug tightening pattern.



FIGURE 1: Multi-nut lightener and lug tightening pattern

### 3. WORKING PRINCIPLE

Gears are arranged in such a way that, by applying approximately 200N force with both hands on to the handle will rotate the gears, finally the required torque is applied on to the spanner to open two wheel nuts at a time. The idea is to develop a complete mechanism in one assembly which can be used in automobile workshops, house holds etc. The machine operates when a force is applied by both hands, due to which central gear rotates in the direction as the handle and by the engagement of driven gears rotate in opposite direction. Bearings are attached to support the drives and proper transmission. The force is transmitted to the sockets at the end of the connecting rods and thus the nuts are removed. The pinion meshes with four auxiliary gears which are in turn connected to a gear whose axle containing the socket spanners at its end. The other end is connected to bevel gear. The main shaft and the follower can be placed at any desired position by using a lock nut arrangement. The entire design depends on the gears and its transmission, even the small error can cause the failure of complete assembly. The proper design involves in analysing stresses acting, tooth engagement and meshing etc. It is essential to analyse and simulate the gear drives with advanced software's and to find the proper engagement of the tooth. Fig 2 shows the modelling of gear drive assembly.

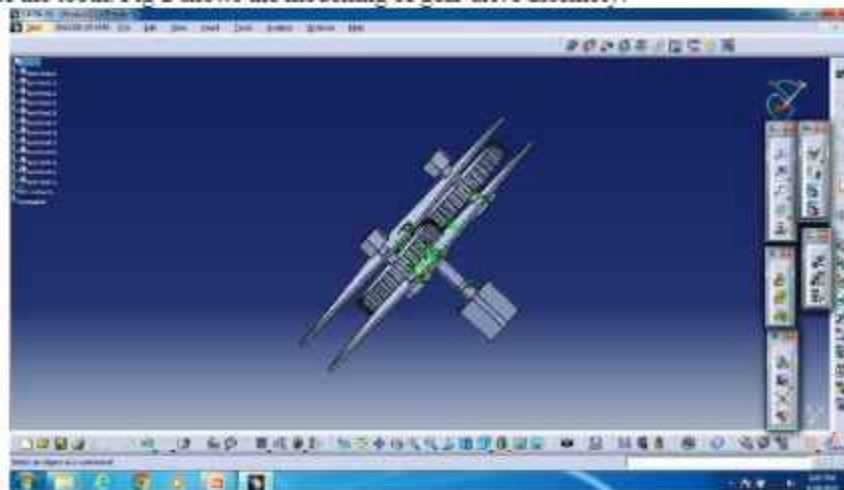

FIGURE 2: Modelling of gear drive assembly

### 4. COMPONENT DETAILS

#### 4.1 Spur Gear

Spur gears are the simplest straight cut gears. It consists of disk or cylinder with projecting teeth radially. If the gears are viewed at 90 degrees from the shaft length the tooth faces are straight and aligned parallel to axis of rotation. Fig 3 shows the spur gear drive



FIGURE 3: Spur gear drive

#### 4.2 Box spanner socket

Socket spanner is a type of spanner that is used as a closed socket format, rather than a typical open type spanner or wrench to turn a fastener, typically in the form of a nut or bolt. The head of the socket wrench resembles the nut or bolt head cover and the sense of the handle not fixed. Fig 4 shows the box spanner socket set.



FIGURE 4: Box spanner socket set

#### 4.3 Bearings

**Ball bearings** are used to reduce the rotational friction and support radial and axial loads. This is achieved by using at least two races to contain the balls and transmit the loads through the balls. As one of the races rotates it causes the balls to rotate as well. Due to the ball rolling they have much lower coefficient of friction than sliding contact bearing. Fig 5 shows the typical ball bearing.

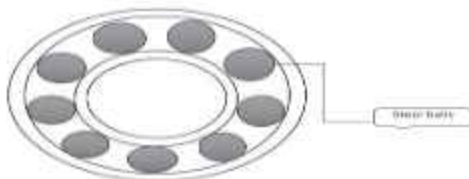

FIGURE 5: A typical ball Bearing

#### 4.4 Power transmitting shaft

Power transmitting shaft is a machine element which is used to transmit power from one place to another. For proper transmission of the power various elements like pulleys, gears, crank etc are mounted on it. Keys and splines are used as mounting elements. The material used for the shaft should have high wear resistant, good heat treatment properties and should have sufficient hardness. Fig 6 shows a typical power transmitting shaft.



FIGURE 6: Power transmitting shaft

#### 4.5 DC Motor

Motors are the electro mechanical devices that convert electrical energy into mechanical energy in the form of torque and rotation. Either alternating current or direct current can be used as an input to the motor. The result is the mechanical motion either translation or rotation. It has mainly two parts namely stator and rotor. Stator is the stationary electrical component and rotor rotates with the main shaft. Fig 7 shows the typical DC motor.



FIGURE 7: shows DC motor

## 5. METHODOLOGY

An extensive survey has been carried out, initially the Modelling of the form tool using CATIA software. Even the parametric modelling of the gears were done based on the results obtained from the design calculations. Finally fabrication of the model has to be performed in accordance with the results obtained.

## 6. CONCLUSION

The design and fabrication of form tool for removing and tightening of the bolts for the tires has been carried out. The gears were designed as per the standards, the validation of the results has to be carried out in been carried out by using finite element software. The results were found to be satisfactory.

## REFERENCES

- [1] Mohd, Azman., 2003 "Design And Fabrication Of Vehicle All Wheel Nuts Remover," International Journal Of Computer Sci. & Electronic Engg. (IJCSEE), Vol.1, Issue 3, ISSN: 2320-401x, pp. 381-384
- [2] Mukhtar, M., 2014 "Design Improvement And Computer Assisted Fabrication On The Impact Wrench For Car Wheel Nuts Puller In Automotive Industry," Australian Journal Of Basic And Applied Sciences, 8(4) Spl., ISSN:1991-8178, pp. 548-553.
- [3] Abd Aziz, A. R., 2008 "Improvement and Optimization of Tyre Nut Remover With 114 PCD," Uni. Malaysia Pahang, Thesis Degree.
- [4] Bhandari, V. B., "Design Of Machine Elements," Tata Mcgraw Hill Publishing House Ltd., Second Edition.
- [5] Dr. Pandya, N. C., and Dr. Shah, C. S., 2009 "Machine Design," Charotar Publishing House Pvt. Ltd., Edition 7<sup>th</sup>.
- [6] [www.macsteel.co.za](http://www.macsteel.co.za)
- [7] Pravin, Kumar, Harsh, Raghuvanshi, 2013 "Design And Analysis Of Spur Gears In Different Geometric Conditions," International Journal Of Engineering And Advanced Technology (IJEAT) ISSN:2249-8958, 3(2), pp. 8-13.
- [8] Malleev, Hartman, Edited By Grover, O. P., "Machine Design," CBS Publishers Pvt. Ltd. Edition 5th.



## DESIGN AND ANALYSIS OF DISHED ENDS

Mohammad Saif Ulla Ameen<sup>1</sup>, Rahul B.N<sup>2</sup>, Rahul P<sup>3</sup>, Syed Ali Faizan Khadr<sup>4</sup>, Nagabhushana M<sup>5</sup>

<sup>1234</sup> UG-students

<sup>5</sup>Associate Professor

Department of Mechanical Engineering  
K.S. Institute of Technology Bangalore -560109

### ABSTRACT

*Dished ends are an important element for pressure vessels and boilers. They cover both ends of the pressure vessel and have wide applications. They are used in nuclear power plants, thermal power plants, and refineries. Usually, the design of dished ends is according to codes like ASME, Indian Standard, etc. The dish is supported by a weld. Internal pressure load, self-weight, the volume of fluid used in the vessel, and seismic load, these loading factors should be taken into consideration while designing. The joint should be considered while designing so that it can withstand various loads. The design for thickness is carried out with reference to Indian Standard 4049. In this paper, the pressure vessel with different end dishes is subjected to internal pressure. The dish ends have been designed for an operating pressure of 2MPa which will be useful for storage applications. Calculations are made to find the thickness of the dish end for the operating pressure. Non-linear axisymmetric Finite Element Analysis considering both geometric and material non-linearity has been performed in SOLIDWORKS software to estimate the stress in the dish of the pressure vessel.*

**Keywords:** Dished ends, Finite element analysis, Formed head, Crown radius, Knuckle radius, Straight face, Factor of safety, Displacement model, Von-mises stress, Maximum allowable stress, and design pressure.

### 1. INTRODUCTION

A dished end is also called a dished head or tank head. It is an important pressure element for pressure vessels and boilers. The dished end is usually used at both ends of the pressure vessel and welded with the shell. According to different geometric shapes, it can be divided into elliptical head, tori-spherical head, hemispherical head, spherical head, conical head, flat head, etc. Hemispherical heads are used for high-pressure vessels and boilers, elliptical heads are used for medium pressure vessels and boilers, whereas tori-spherical heads are used for low-pressure vessels and boilers.

There are different types of dish ends, they are as followed

- Flat Head.
- Ellipsoidal head.
- Tori-spherical head.
- Hemispherical head.

Commonly used terms in above listed dished ends are

- Inside Diameter (ID)
- Crown radius (CR)
- Knuckle Radius (KR)
- Dish End Total Height (H)
- Straight Face (SF)
- Thickness (t)

**Applications of Dished ends:** - A pressure vessel is a container designed to hold liquids or gases at a pressure often different from the surrounding atmosphere. Due to the nature of the substances being stored, which in certain cases may be hazardous, it is imperative that the construction material meets the exacting safety standards required for the application. Depending on the size and purpose the applications of dished ends vary from one sector to another and the type of pressure vessel and its geometry.

Major Applied sectors are: Petrochemical plants.

- Pharmaceutical industry.
- Oil and gas industry.
- Nuclear power industry.
- Biotechnology.
- Food industry

## 2. MATERIAL

The material used is FE 410 Steel.



The material properties are as follows



| Structural steel | Density               | Young's modulus                     | Poisson's ratio              | Modulus of rigidity                        | Ultimate tensile stress | Yield stress |
|------------------|-----------------------|-------------------------------------|------------------------------|--|-------------------------|--------------|
| 2062:2011        | 7850kg/m <sup>3</sup> | 2*10 <sup>5</sup> n/mm <sup>2</sup> | Elastic: 0.3<br>Plastic: 0.5 | 0.739*10 <sup>5</sup><br>n/mm <sup>2</sup> | 490MPa                  | 320MPa       |

## 3. METHODOLOGY

To achieve the design and analysis of the dish ends, calculations are made in reference to Indian Standard 2825 – 1969 to determine the thickness for internal pressure of 2MPa. The calculations made resulted in a thickness of about 50mm. Solidworks application is used to achieve 3D modelling, drafting, and Finite Element Analysis of the dish end. The analysis is done to determine Von-mises stress, resultant displacement, and factor of safety for all the formed ends i.e. tori-spherical dish end, ellipsoidal dish end, and hemispherical dish end.

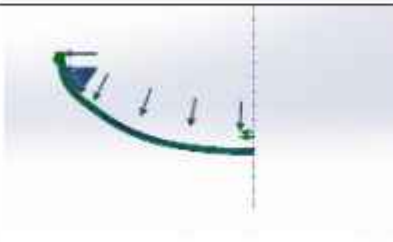
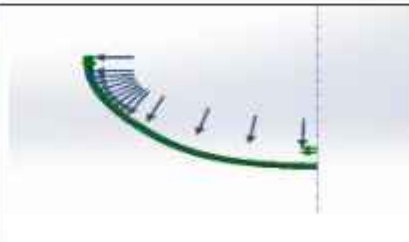
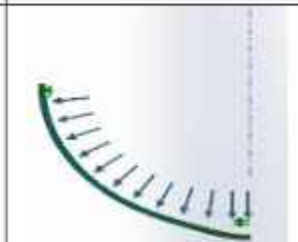
## 4. RESULT and DISCUSSION

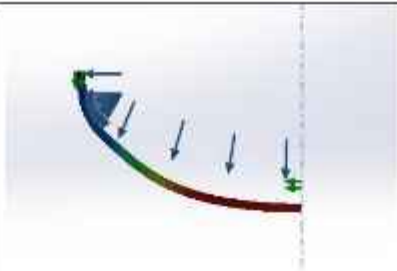
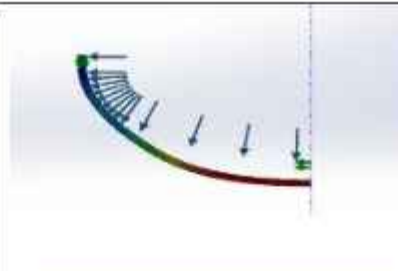
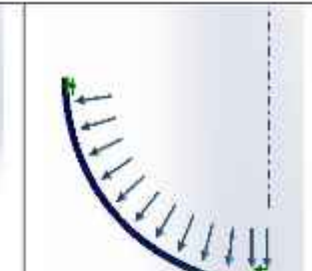
| Type of dish end                       | Tori-spherical  | Ellipsoidal  | Hemispherical   |  |  |   |     |     |  |  |   |     |     |  |  |
|--|---|--|---|--|--|---|-----|-----|--|--|---|-----|-----|--|--|
| Thickness                              | 50mm  | 50mm   | 50mm  |  |  |   |     |     |  |  |   |     |     |  |  |
| Internal pressure                      | 2MPa  | 2MPa   | 2MPa  |  |  |   |     |     |  |  |   |     |     |  |  |
| 3D Model                               |    |  |  |  |  |   |     |     |  |  |   |     |     |  |  |
| Von-mises stress                       |  <table border="1" data-bbox="384 1727 778 1832"> <thead> <tr> <th>Min</th> <th>Max</th> </tr> </thead> <tbody> <tr> <td>6.673*10<sup>6</sup>N/m<sup>2</sup></td> <td>2.030*10<sup>8</sup>N/m<sup>2</sup></td> </tr> </tbody> </table> | Min  | Max   | 6.673*10 <sup>6</sup> N/m <sup>2</sup> | 2.030*10 <sup>8</sup> N/m <sup>2</sup> |  <table border="1" data-bbox="799 1727 1209 1832"> <thead> <tr> <th>Min</th> <th>Max</th> </tr> </thead> <tbody> <tr> <td>7.568*10<sup>5</sup>N/m<sup>2</sup></td> <td>1.259*10<sup>8</sup>N/m<sup>2</sup></td> </tr> </tbody> </table> | Min | Max | 7.568*10 <sup>5</sup> N/m <sup>2</sup> | 1.259*10 <sup>8</sup> N/m <sup>2</sup> |  <table border="1" data-bbox="1230 1727 1528 1832"> <thead> <tr> <th>Min</th> <th>Max</th> </tr> </thead> <tbody> <tr> <td>1.132*10<sup>6</sup>N/m<sup>2</sup></td> <td>9.947*10<sup>7</sup>N/m<sup>2</sup></td> </tr> </tbody> </table> | Min | Max | 1.132*10 <sup>6</sup> N/m <sup>2</sup> | 9.947*10 <sup>7</sup> N/m <sup>2</sup> |
| Min                                    | Max   |  |   |  |  |   |     |     |  |  |   |     |     |  |  |
| 6.673*10 <sup>6</sup> N/m <sup>2</sup> | 2.030*10 <sup>8</sup> N/m <sup>2</sup>  |  |   |  |  |   |     |     |  |  |   |     |     |  |  |
| Min                                    | Max   |  |   |  |  |   |     |     |  |  |   |     |     |  |  |
| 7.568*10 <sup>5</sup> N/m <sup>2</sup> | 1.259*10 <sup>8</sup> N/m <sup>2</sup>  |  |   |  |  |   |     |     |  |  |   |     |     |  |  |
| Min                                    | Max   |  |   |  |  |   |     |     |  |  |   |     |     |  |  |
| 1.132*10 <sup>6</sup> N/m <sup>2</sup> | 9.947*10 <sup>7</sup> N/m <sup>2</sup>  |  |   |  |  |   |     |     |  |  |   |     |     |  |  |

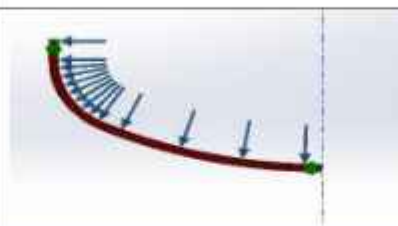
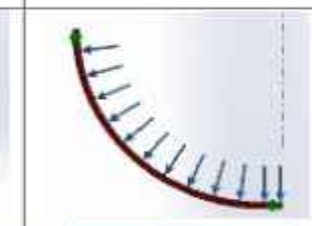
| Deflection                       |    |  |   |                                  |                     |   |                     |     |                                  |                     |   |     |     |                                  |                                  |
|----------------------------------|---|--|--|----------------------------------|---------------------|---|---------------------|-----|----------------------------------|---------------------|---|-----|-----|----------------------------------|----------------------------------|
|                                  | <table border="1"> <thead> <tr> <th>Min</th> <th>Max</th> </tr> </thead> <tbody> <tr> <td><math>2.471 \times 10^{-3} \text{mm}</math></td> <td>2.310mm</td> </tr> </tbody> </table> | Min  | Max  | $2.471 \times 10^{-3} \text{mm}$ | 2.310mm             | <table border="1"> <thead> <tr> <th>Min</th> <th>Max</th> </tr> </thead> <tbody> <tr> <td><math>1.454 \times 10^{-3} \text{mm}</math></td> <td>1.491mm</td> </tr> </tbody> </table> | Min                 | Max | $1.454 \times 10^{-3} \text{mm}$ | 1.491mm             | <table border="1"> <thead> <tr> <th>Min</th> <th>Max</th> </tr> </thead> <tbody> <tr> <td><math>1.587 \times 10^{-1} \text{mm}</math></td> <td><math>6.794 \times 10^{-1} \text{mm}</math></td> </tr> </tbody> </table> | Min | Max | $1.587 \times 10^{-1} \text{mm}$ | $6.794 \times 10^{-1} \text{mm}$ |
|                                  | Min   | Max  |  |                                  |                     |   |                     |     |                                  |                     |   |     |     |                                  |                                  |
| $2.471 \times 10^{-3} \text{mm}$ | 2.310mm   |  |  |                                  |                     |   |                     |     |                                  |                     |   |     |     |                                  |                                  |
| Min                              | Max   |  |  |                                  |                     |   |                     |     |                                  |                     |   |     |     |                                  |                                  |
| $1.454 \times 10^{-3} \text{mm}$ | 1.491mm   |  |  |                                  |                     |   |                     |     |                                  |                     |   |     |     |                                  |                                  |
| Min                              | Max   |  |  |                                  |                     |   |                     |     |                                  |                     |   |     |     |                                  |                                  |
| $1.587 \times 10^{-1} \text{mm}$ | $6.794 \times 10^{-1} \text{mm}$  |  |  |                                  |                     |   |                     |     |                                  |                     |   |     |     |                                  |                                  |
| Factor of safety                 |    |  |   |                                  |                     |   |                     |     |                                  |                     |   |     |     |                                  |                                  |
|                                  | <table border="1"> <thead> <tr> <th>Min</th> <th>Max</th> </tr> </thead> <tbody> <tr> <td>1.392</td> <td><math>4.236 \times 10^1</math></td> </tr> </tbody> </table>                | Min  | Max  | 1.392                            | $4.236 \times 10^1$ | <table border="1"> <thead> <tr> <th>Min</th> <th>Max</th> </tr> </thead> <tbody> <tr> <td>2.245</td> <td><math>3.735 \times 10^2</math></td> </tr> </tbody> </table>                | Min                 | Max | 2.245                            | $3.735 \times 10^2$ | <table border="1"> <thead> <tr> <th>Min</th> <th>Max</th> </tr> </thead> <tbody> <tr> <td>2.842</td> <td><math>2.498 \times 10^2</math></td> </tr> </tbody> </table>  | Min | Max | 2.842                            | $2.498 \times 10^2$              |
|                                  | Min   | Max  |  |                                  |                     |   |                     |     |                                  |                     |   |     |     |                                  |                                  |
| 1.392                            | $4.236 \times 10^1$   |  |  |                                  |                     |   |                     |     |                                  |                     |   |     |     |                                  |                                  |
| Min                              | Max   |  |  |                                  |                     |   |                     |     |                                  |                     |   |     |     |                                  |                                  |
| 2.245                            | $3.735 \times 10^2$   |  |  |                                  |                     |   |                     |     |                                  |                     |   |     |     |                                  |                                  |
| Min                              | Max   |  |  |                                  |                     |   |                     |     |                                  |                     |   |     |     |                                  |                                  |
| 2.842                            | $2.498 \times 10^2$   |  |  |                                  |                     |   |                     |     |                                  |                     |   |     |     |                                  |                                  |
|                                  |   |  | <table border="1"> <thead> <tr> <th>Min</th> <th>Max</th> </tr> </thead> <tbody> <tr> <td>2.842</td> <td><math>2.498 \times 10^2</math></td> </tr> </tbody> </table> | Min                              | Max                 | 2.842   | $2.498 \times 10^2$ |     |                                  |                     |   |     |     |                                  |                                  |
| Min                              | Max   |  |  |                                  |                     |   |                     |     |                                  |                     |   |     |     |                                  |                                  |
| 2.842                            | $2.498 \times 10^2$   |  |  |                                  |                     |   |                     |     |                                  |                     |   |     |     |                                  |                                  |

Chemicals, fuels, and gases exert a maximum internal pressure of 2MPa and the thickness of the dished ends is calculated for the same internal pressure. The analysis for the dished ends is made for the same pressure. The analysis is done for Von-mises stress, deflection, and factor of safety. The result of the analysis declared the modelled parts as safe.

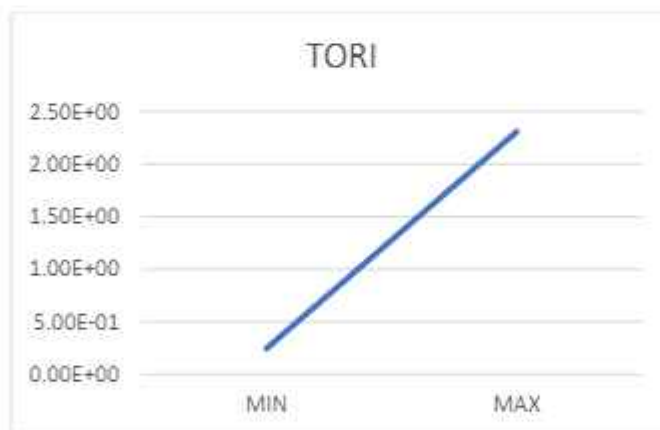

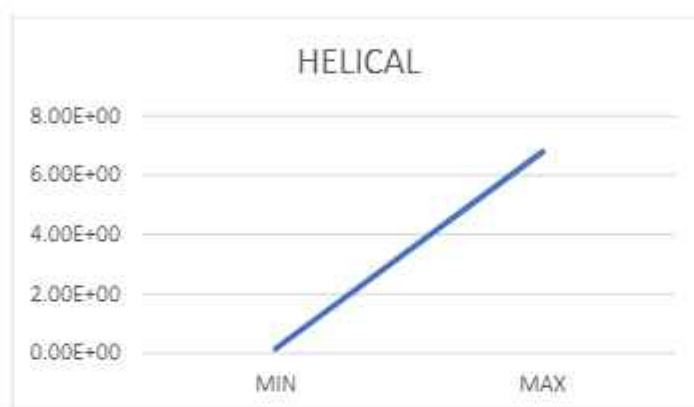
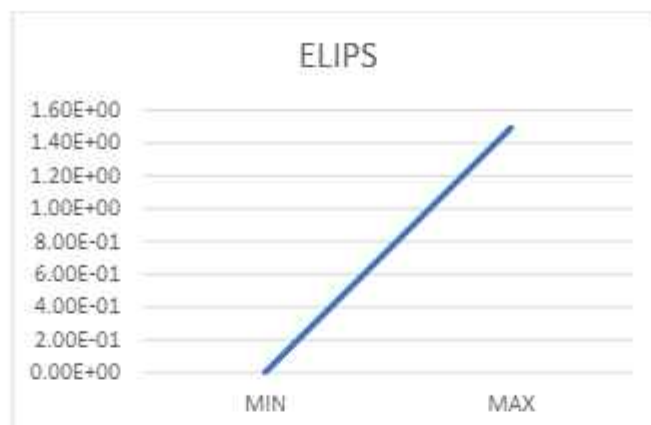

From the above graphs it can be concluded that tori-spherical dish ends have minimum deflection under internal pressure of 2MPa and thickness of 50mm when compared with other types of dish ends.

## 5. CONCLUSION

This paper compares the formed head i.e. tori-spherical head, ellipsoidal head and hemispherical head by means of deflection in each head.

## ACKNOWLEDGMENT

Our most sincere and grateful acknowledgment to the holy sanctum of K.S. INSTITUTE OF TECHNOLOGY, the temple of learning, for giving us the opportunity to the degree in Mechanical Engineering and thus helping us to shape our career. First and foremost we would like to express our gratitude to Dr. Dilip Kumar K, Principal, K S Institute of Technology for his whole hearted support during our stay at KS Institute of technology.

We express our sincere thanks to Dr. Nirmala L, Student project coordinator, K S Institute of Technology for having given this opportunity and support to carry out our project work.

We take immense pleasure in thanking Dr. Umashankar M, Professor and Head of the Department, Mechanical Engineering for having given this opportunity and support to carry out our project work.

## REFERENCES

- [1] Bandrupalli Praneeth, T.B.S.Ra, "Finite Element Analysis of Pressure Vessel and Piping Design", International Journal of Engineering Research and Applications (IJERA) ISSN: 2248-9622 Vol. 2, Issue 1, Jan-Feb 2012, pp. 355-361
- [2] Siva Krishna Raparla & T.Seshaiah, "Design and analysis of multilayer high pressure vessels", International Journal of Engineering Research and Applications (IJERA) -Vol. 2, Issue 1, Jan-Feb 2012, pp. 355-361
- [3] Bogdan Szybiński, "Design of flat ends in pressure boilers with circular and elliptical stress relieve grooves", Applied Mechanics and Materials, vol. 477-478, Trans Tech Publications, Ltd., Dec. 2013, pp. 49-53
- [4] Suresh c. Maidargi, "Chemical process equipment: design and drawing (volume 1)", PHI Learning; 2nd edition -1 August 2015
- [5] Bhattacharyya, "Introduction To Chemical Equipment Design Mechanical Aspects", CBS publications 1st edition 1 January 2017

- [6] P. D. Kulkarni ,” Chemical Instrumentation and Process Control”, Nirali Prakashan, Educational Publishers; 5th ed. edition 1 March 2019 .
- [7] Sagarsingh Kushwah ,Shreyash kumar ,Parekh Harsh Mistry ,Jainil Darji ,Rutvik Gandhi,” Analysis of cylindrical pressure vessels with dissimilar ends and material comparison”, ISSN 2214-7853 Issue 2020.
- [8] Korukonda sivaparvathiSri.Palle Prasad,” Design and static thermal analysis of different pressure vessel heads and materials using FEM”, Open Access International Journal Of Science And Engineering -Volume 5 Issue 8 , August 2020.

## FABRICATION OF REMOTE-CONTROL MOTORIZED SCREW JACK

<sup>1</sup>Lingesh Gowda. R, <sup>2</sup>Mohith. J, <sup>3</sup>Kiran Kashyap. GB, <sup>4</sup>Mr. Ranganath.N

<sup>1,2,3</sup> Students

<sup>4</sup>Assistant Professor

Dept. of Mechanical Engineering  
K.S. Institute of Technology, Bangalore 560109

### ABSTRACT

*The introduction of the concept of remote-controlled motorized screw jack. when the weight of the vehicle exceeds certain limit, it cannot be lifted by the person, in such cases we are in need of a jack. There are few jacks to lift the vehicle but it is operated manually. When it is done automatic it becomes more convenient to use. In order to implement this idea, we have developed a system called motorized jack which is controlled through android app, by using this we can easily lift the jack up and down thus helps to reduce the burden of the worker. The main reason to fabricate the motorized screw jack is to avoid the fatigue of human during lifting of the load. The project is less cost and good efficient for operating. This jack can lift a vehicle weight of 600 to 800kg which is more use for garage workers. This jack can be operated using an android mobile. Bluetooth module is connected to the controller to take the commands from the mobile so that the motor can be rotated to lift the jack. motor runs through the battery. Here we are using arduono as our controller and Bluetooth module.*

Keywords: DC Motor, Automatic car jack, Bluetooth, Android app, IOT.

### 1. INTRODUCTION

This project work titled “**remote controlled motorized screw jack**” has been conceived having studied the difficulty in lifting the any type of light vehicles through smart phone apps. Our survey in the regard in several car owners or drivers, revealed the facts that mostly some difficult methods were adopted in lifting the vehicles where in need of maintenance, repair and while the tyre gets punctured. A screw jack is a portable device consisting of a screw mechanism used to raise or lower the load and lift heavy objects.

There are mainly two types of jacks-hydraulic and mechanical. A hydraulic jack consists of a cylinder and piston mechanism. The movement of the piston rod is used to raise or lower the load. Mechanical jacks can be either hand operated or power driven. Jacks are used frequently in raising cars so that a tire can be changed.

Nowadays smart phones are becoming more powerful and have gradually turned into an all-purpose portable device and provided people for their daily use. Bluetooth is mainly used for data exchange; add new features to smart phones. Bluetooth technology, shows its advantage by integrating with smart phones. It has changed how people use digital device at anywhere, and has transferred traditional wired digital devices into wireless devices. smart phones have gradually turned into an all-purpose portable device and provided people for their daily use. Android has complete software package consisting of an operating system, middleware layer and core applications. In this paper we present a screw jack controlled by mobile phone, tablets. In our work, move the screw jack upward, backward by the android application such as Bluetooth Terminal. The operation is made to be simple that even an unskilled labour can handle, this is an era of automation where it is broadly defined as replacement of manual effort by mechanical power in all degrees of automation.

### 2. MATERIALS AND METHODS

#### 2.1 Screw Jack



FIGURE 1. Screw jack

A screw jack consists of a heavy-duty vertical screw with a load table mounted on its top, which screws into a threaded hole in a stationary support frame with a wide base resting on the ground. A rotating collar on the head of the screw has holes into which the handle, a metal bar, fits. When the handle is turned clockwise, the screw moves further out of the base, lifting the load resting on the load table. In order to support large load forces, the screw is usually formed with ACME threads.

### 2.1.1 Specifications of screw jack

- Rugged alloyed steel construction with heavy duty steel frame and saddle
- Oversize: 4 ¼ inch wide base
- Lift range: 3 inches 15 inches
- Lift weight: 1000kg

## 2.2 Lead Acid Battery



FIGURE 2. Lead acid battery

The lead–acid battery consists of two electrodes submerged in an electrolyte of sulfuric acid. The positive electrode is made of grains of metallic lead oxide, while the negative electrode is attached to a grid of metallic lead. Lead–acid batteries are classified into two types: flooded and valve-regulated. Flooded lead–acid batteries are less expensive but require more maintenance and ventilation than the valve-regulated lead–acid batteries.

### 2.2.1 Specifications of lead acid battery

- voltage : 12 V
- current : 7.5 amps

## 2.3 DC MOTOR



FIGURE 3. DC motor

A DC motor is any of a class of electrical machines that converts direct current electrical power into mechanical power. A direct current, or DC, motor is the most common type of motor. DC motors normally have just two leads, one positive and one negative. If you connect these two leads directly to a battery, the motor will rotate. If you switch the leads, the motor will rotate in the opposite direction.

### 2.3.1 Specifications of DC Motor

- voltage : 12 V
- current : 5amps
- speed : 60rpm

### 2.4 Bluetooth module



FIGURE 4. Bluetooth module

Among the four popular wireless connections that often implemented in HAS project, Bluetooth is being chosen with its suitable capability. Bluetooth with globally available frequencies of 2400Hz is able to provide connectivity up to 100 meters at speed of up to 3Mbps depending on the Bluetooth device. Prior to implementation of Bluetooth-based application on the phone, several software packages are required which include Java Development Kit (JDK), the Eclipse software environment, Android Development Tools (ADT) and Android SDK (Software Development Kit).

### 2.5 Relay switch



FIGURE 5. Relay switch

We are using SPST (Single-Pole Single-Throw) relay. Two relays are used for backward and forward motion of motor. A relay is an electrically worked switch. Current moving through the loop of the transfer makes an attractive field which draws in a switch and changes the switch contacts. The coil current can be on or off. So transfers have two switch positions and they are twofold toss (changeover) switches. Transfers permit one circuit to switch a second circuit which can be totally discrete from the first. The connection is attractive and mechanical.

### 2.6 Microcontroller

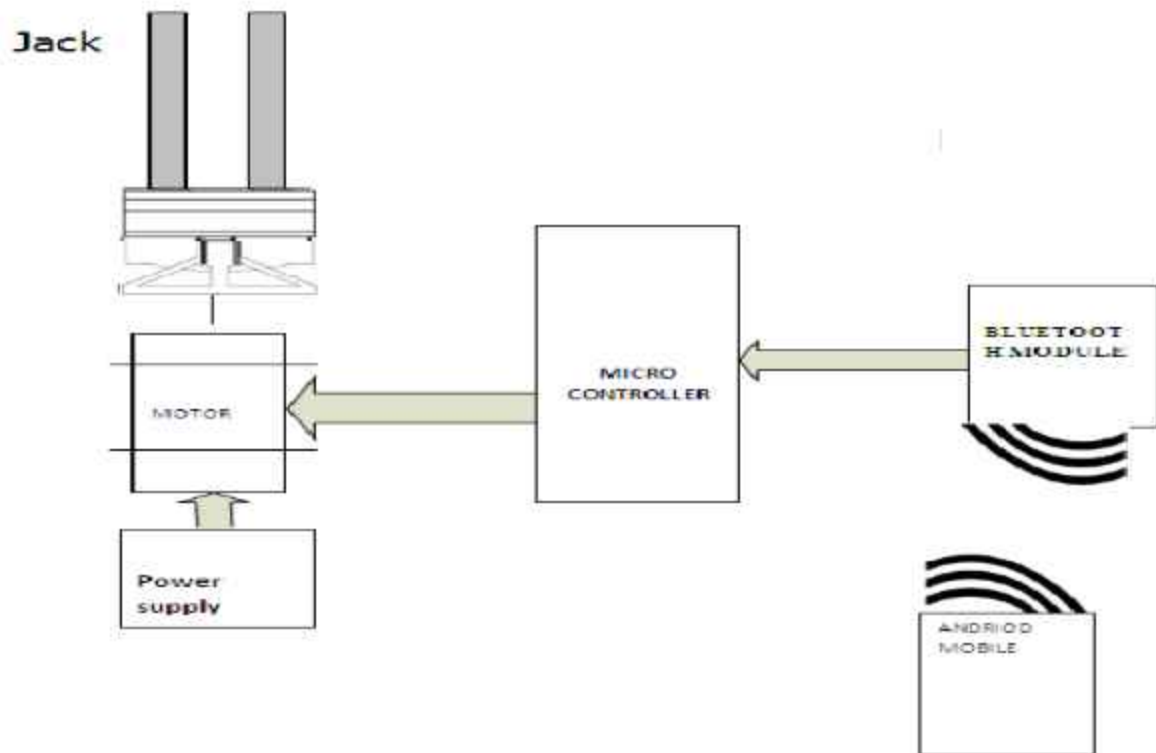



FIGURE 6. Microcontroller

Microprocessors and microcontrollers are widely used in embedded systems products. Microcontroller is a programmable device. A microcontroller has a CPU in addition to a fixed amount of RAM, ROM, I/O ports and a timer embedded all on a single chip. The fixed amount of on-chip ROM, RAM and number of I/O ports in microcontrollers makes them ideal for many applications in which cost and space are critical. The 8052 is an 8-bit processor, meaning that the CPU can work on only 8 bits of data at a time. Data larger than 8 bits has to be broken into 8-bit pieces to be processed by the CPU.

### 3. BLOCK DIAGRAM



### 4. WORKING PRINCIPLE

An Android controlled automobile project that allows user to control a battery powered automobile wireless through an android application. The system uses a bluetooth modem as a medium to transmit signals between the android based phone and to the Bluetooth jack. The commands are sent in the form of string variables by the android application through an active bluetooth connection. These string variables are then received by bluetooth modem and then forwarded to the Microcontroller.

The microcontroller now processes the data sent by bluetooth modem and checks for user commands. On recognizing direction commands sent by user (Forward/Backward), the microcontroller sends signals to appropriate driver IC's. The driver IC's now operate motors to achieve the desired movement of the automobile as sent by microcontroller.

The lead-acid battery is used to drive the D.C motor. The D.C motor shaft is connected to the spur gear. If the power is given to the D.C motor, it will run so that the spur gear also runs to the slow speed of the D.C motor. The screw jack and moves the piston upward, so that the vehicle lifts from ground. The vehicle is lifted by using the lifting flat form in the top of the screw jack. The motor is drawn supply from the battery. The lifting and uplifting is done by changing the battery supply to the motor simply.

### 5. CONCLUSION

This project has been made to help the workers who are working in the automobile garages, service station and also elderly people. This project reduces the effort of lifting heavy vehicle weight and also reduces the time. This project has also reduced the cost involved in the concern. This jack can lift a vehicle weight of 600 to 800kg which is more useful for garage workers. This jack can be operated using an android mobile. Bluetooth module is connected to the controller to take the commands from the mobile so that the motor can be rotated to lift the jack. Motor runs through the battery. Here we are using arduino as our controller and Bluetooth module. The whole model can be operated anywhere.

## ACKNOWLEDGEMENT

We would like to express our profound gratitude to our project guide Mr Ranganath N, Assistant professor, KSIT for the guidance, monitoring and cooperation, and our friends and their constant encouragement in making this project successful.

## REFERENCES

- [1] R. S. Khurmi, a text book of machine design, Eurasia Publishing House PDF.
- [2] Dr. Sandhu Singh "Machine Design" Khanna Publishers, Delhi, 1997.
- [3] (Arduino, iOS, Android and Technology Tips)
- [4] Heidi Monson (1999) Bluetooth technology and implementations, John Wiley & Sons.
- [5] Piyare, R. and Tazil, M. (2011) "Bluetooth based home automation system using Android phones". IEEE 15TH International Symposium on Consumer Electronics (ISCE), 14-17 June 2011, Singapore.
- [6] Lokhande Tarachand G., Chatpalliwar Ashwin S. And Bhotar Amar A., "Optimizing Efficiency of Square Threaded Mechanical Screw Jack by Varying Helix Angle", International Journal of Modern Engineering Research (IJMER) Vol.2 Issue.1, pp. 504-508, Jan-Feb 2012.

## FIBER REINFORCED COMPOSITES- A REVIEW

Pradyumna G<sup>1</sup>, Sumukha T V<sup>1</sup>, Shrivarshini G M<sup>1</sup>, Varun M<sup>1</sup>, Umashankar.M<sup>2</sup>

<sup>1</sup>Students, <sup>2</sup>Professor and Head  
Department Of Mechanical Engineering  
K.S Institute of Technology (KSIT), Bengaluru, India

### ABSTRACT

*A hybrid composite material is one that is made up of two or more constituent fibres. materials have chemical or physical properties that are noticeably diverse, and they are combined to form a material with qualities that are distinct from the separate constituents. Composites have been discovered to be the most promising and discriminating material available in the twenty-first century. Composites reinforced with fibres of synthetic or natural materials are becoming more popular as the market grows in demand for lightweight materials with high strength for specific applications. Not only does fiber-reinforced polymer composite have a high strength-to-weight ratio, but it also has exceptional properties such as high durability, stiffness, damping property, flexural strength, and resistance to corrosion, wear, impact, and fire. Metal matrix composites (MMCs), ceramic matrix composites (CMCs), carbon/carbon composites (C/C), and polymer matrix composites (PMCs) or polymeric composites are the four types of fibre reinforced composites. Synthetic fibres (in British English; see spelling variations) are fibres created by humans through chemical synthesis.*

**Keywords:** Types of Synthetic Fibers-Rayon,Nylon,Polyester,Acrylic.

### 1. INTRODUCTION

#### 1.1 Synthetic fibres

Man-made fibres made from chemical substances that are used to make clothing and other useful items. Polymerization is used to create these. Synthetic fibres can be fully synthetic or semi-synthetic. Chemicals are used to make purely synthetic fibres such as nylons, polyesters, and acrylics, whereas natural polymers are used to make semisynthetic fibres such as rayons. Synthetic fibres are formed by extruding fiber-forming materials through spinnerets.



FIGURE 1. Synthetic fiber

#### Types of Synthetic fibres-

- Rayon Fibres –

Rayon possesses qualities that are akin to silk. It is a man-made fibre that is less expensive than silk. It's made from wood pulp.

- Nylon fibres -

These fibres are created from water, coal, and air and are strong, light, glossy, and easy to wash. The fibre is entirely synthetic and far more durable than steel wire.

#### 1.2 Natural fibres

Fibres produced by geological processes or from the bodies of plants or animals. They can be used as a component of composite materials, where the fibre orientation influences the properties. Natural fibres can also be matted to create sheets of paper or felt. Natural fibres have been used for textile materials since before recorded history. The

discovery of flax and wool fabrics at excavation sites of Swiss lake dwellers is likely the oldest indication of fibre use (7th and 6th centuries BCE). Prehistoric peoples also used a variety of vegetable fibres.



FIGURE 2. Natural fibre

Types of Natural fibres-

- **Wool:** Wool is a natural textile fibre obtained from sheep, goats and camels. It traps a lot of air. Air is a bad conductor of heat. This makes clothes made from wool useful in winter.
- **Silk:** Silk is also a natural textile fibre which is obtained from silkworms. The rearing of silkworm to obtain silk is known as sericulture.
- **Cotton:** It is one of the plant fibres that are used to make clothes. It is a soft staple fibre that is found as a boll around the seeds in a cotton plant.
- **Jute:** It is a vegetable fibre that is soft, shiny and is spun into coarse strong threads. Jute fibres are totally biodegradable and recyclable materials, i.e., environmentally friendly materials.
- **Basalt fibre** is a dark-coloured, fine-grained solidified volcanic rock. It is primarily composed of Silicone Dioxide ( $\text{SiO}_2$ ), Aluminium Oxide ( $\text{Al}_2\text{O}_3$ ), Iron Oxide ( $\text{FeO}+\text{Fe}_2\text{O}_3$ ), Calcium Oxide ( $\text{CaO}$ ), Magnesium Oxide ( $\text{MgO}$ ), and Sodium Oxide. Basalt is a natural material that is friendly to the environment. It is used in the production of basalt fibres.

### 1.3 Fiberglass

Fiberglass is a common type of glass fibre-reinforced plastic. The fibres can be arranged randomly, flattened into a sheet known as a chopped strand mat, or woven into glass cloth. The plastic matrix can be a thermoset polymer matrix (typically based on thermosetting polymers like epoxy, polyester resin, or vinyl ester resin) or a thermoplastic matrix.



FIGURE 3. Fiberglass

#### 1.3.1 Types of Fibreglass

- **A-glass** is also known as alkali glass or soda-lime glass. It is the most commonly available type of fiberglass. About 90% of the glass that is manufactured is alkali glass. It is the most prevalent type that is used in making glass containers like jars and bottles for food and beverages, and windowpanes.
- **C-glass**, also known as chemical glass, has the highest chemical resistance. It maintains structural balance in corrosive environments.

- E-glass is also known as electrical glass. It is a lightweight composite material that has applications in aerospace, marine, and industrial settings. E-glass fibreglass cloth is an industry standard that offers a good mix of performance and cost. It has an excellent draping characteristic that makes it easier to work with.

## EPOXY RESIN

The family of basic components or cured end products of epoxy resins is known as epoxy. It's well-known for its strong adhesive properties, making it a useful product in a variety of industries. It is heat and chemical resistant, making it an excellent choice for anyone who requires a solid hold under pressure. Epoxy resin is a long-lasting compound that can be used on a variety of surfaces, including wood, fibres, glass, and metal.

## 2. MATERIALS AND METHODOLOGY

### 2.1 COMPONENTS

Hybrid composites are materials made up of two or more types of fibres embedded in a single polymer matrix. Hybrid composite materials are increasingly being used in a wide range of engineering applications due to their improved properties and numerous advantages over traditional composite materials.

#### I. BASALT FIBER:

Basalt fibres have higher strength and elastic modulus than standard E glass and are comparable to special high strength S glass and carbon fibres. As a result, they provide car manufacturers with the opportunity to significantly reduce the cost of SMC/BMC parts while maintaining high strength and stiffness. Basalt fibres have the same dielectric properties as glass fibres. Furthermore, switching from glass to basalt has no effect on radar transparency.



FIGURE 2. Basalt Fiber

#### II. JUTE FIBER:

Jute fibre is completely biodegradable and recyclable, making it environmentally friendly. It has high tensile strength, low extensibility and ensures better breathability of fabrics. Jute has good insulating and antistatic properties, as well as low thermal conductivity and a moderate moisture regain. Jute also has acoustic insulating properties and is manufactured without causing skin irritations. Jute can be blended with other fibres, both synthetic and natural.



FIGURE 3. Jute Fibre

### III. EPOXY:

Lapox L12 is a liquid, unmodified epoxy resin with a medium viscosity that can be used to make glassfiber reinforced composites with a variety of hardeners. The hardener used is determined by the processing method and the properties required of the cured composite. Hardener K6 is a room temperature curing liquid hardener with a low viscosity. It is frequently used for hand lay up applications. Because it is highly reactive, it has a short pot life and a rapid cure at normal ambient temperatures. Laminates can withstand operating temperatures of 1000 C.



FIGURE 4. Lapox L-12 With K-6 Hardener

## 2.2 METHODOLOGY

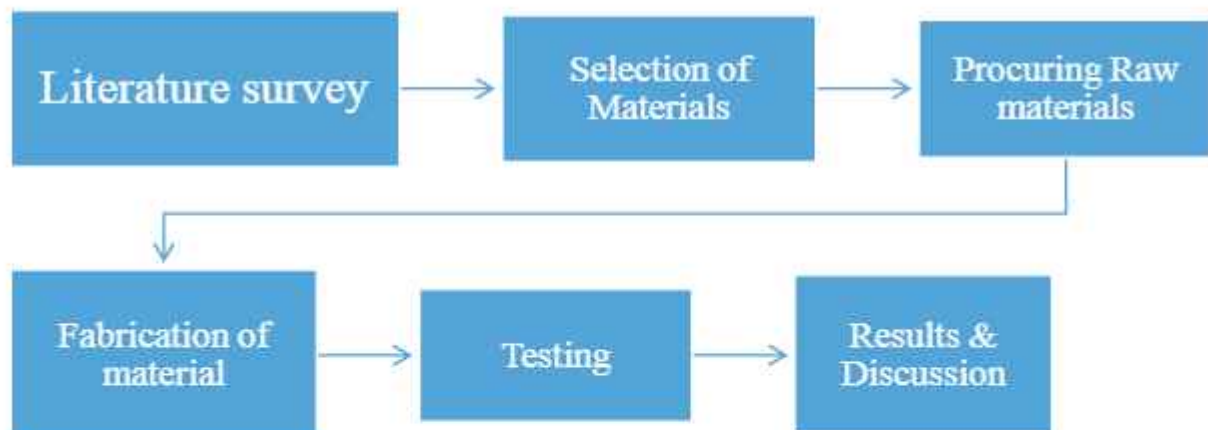

### 2.2.1 HAND LAYUP TECHNIQUE

The hand lay-up method is a composite material moulding technique in which the final product is created by overlapping a certain number of different layers.

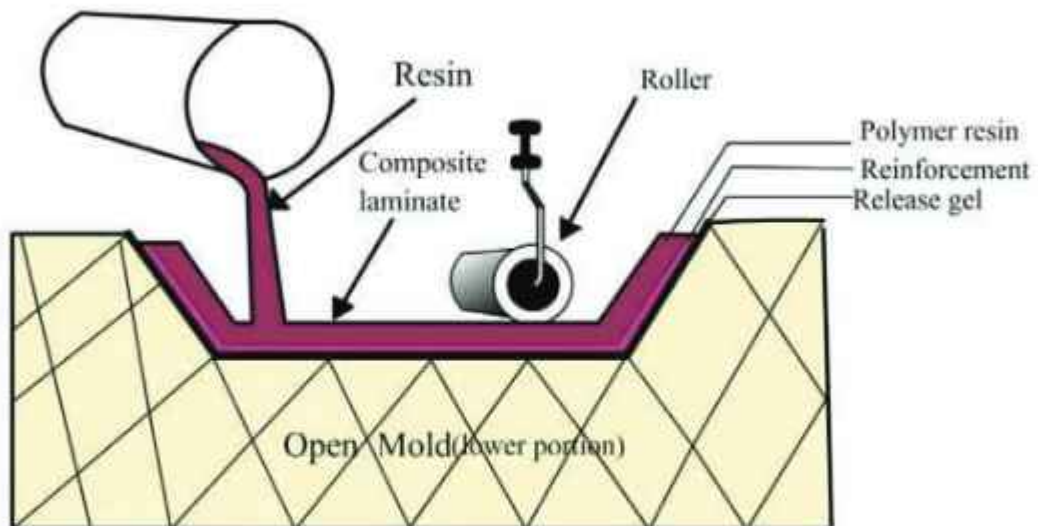

FIGURE 5. Hand layup Technique



FIGURE 6. Specimen After Fabrication

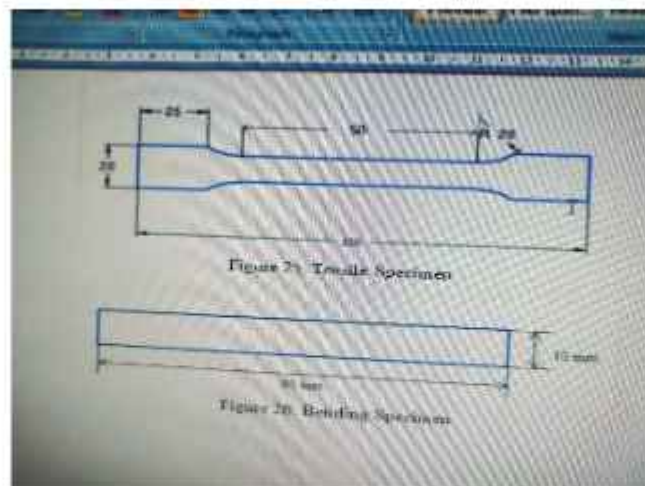

FIGURE 8. Dimensions of Testing Material



FIGURE 9. Material being testing

## CONCLUSIONS

Procured a Vitrified tile in order to get a smooth surface finish and to support our composite material.

On the tile, a plastic sheet on which we carried out the hand layup technique to get a glossy surface finish and to easily remove the material once it completely dries.

Spread a layer of epoxy mixed with hardener on the plastic sheet and placed a layer of basalt fiber and on which again a layer a epoxy was used to place jute, this process was repeated till we achieved the required thickness

## ACKNOWLEDGEMENT

The authors would like to thank Dr.Umashankar M, Professor And Head of Department of Mechanical Engineering and Dr. Girish TR, Associate Professor Department of Mechanical Engineering K.S Institute of Technology for supporting these research activities.

## REFERENCES

- [1] Properties and Applications of Basalt Fibre and Its Composites- Zongwen Li1, Jianxun Ma, Hongmin Ma1, Xin Xu1 School of Human Settlements and Civil Engineering, Xi'an Jiaotong University, Xi'an, Shaanxi 710049, China.
- [2] Comparative study of effect of Basalt, Glass and Steel Fibre on compressive strength-Ranjitsinh K. Patil, D. B. Kulkarni
- [3] Basalt Fibers and its composites -Krishna Pareek, Dr. Purnachandra Saha.
- [4] Basalt Fiber as a reinforcement of polymer composites - Tibor CZIGÁNY, János VAD and Kornél PÓLÓSKÉI Department of Polymer Engineering, Faculty of Mechanical Engineering, Budapest University of Technology and Economics.
- [5] Synthesis and research of epoxy resin toughening agent- Hongming Ma, Nannan Hu, Cheng Wu, Yinfeng Zhu, Yi Cao and Qing Qing Chen4.



## FABRICATION OF SONAR GLASSES FOR VISUALLY IMPAIRED

Darshan G<sup>1</sup>, <sup>2</sup>Harish B<sup>1</sup>, K Jeevan Kumar<sup>1</sup>, Manoj A<sup>1</sup>, Rajesh G L<sup>2</sup>

<sup>1</sup>UG Students, <sup>2</sup>Assistant Professor

Department of Mechanical Engineering,  
K.S. Institute of Technology Bangalore- 560109

### ABSTRACT

*Blind mobility is one of the major challenges encountered by visually impaired persons in their daily lives. Their life and activities are greatly restricted by loss of eyesight. They normally travel using blind navigation system or by their accumulated memories in their long term exploration. The main objective of the present work is to develop a low cost, reliable, portable, user friendly, low power and robust solution for smooth navigation. This paper (Smart Glasses for Blind People), as meant are the glasses are for visually impaired people. It has an in-built sensor in it which spreads ultrasonic waves in the direction the person is going by scanning at most 30 cm range. As soon as the obstacle is detected, the sensor detects it and vibrates.*

**Keywords:** Smart Glasses, Ultrasonic Sensors, Blind People.

### 1. INTRODUCTION

In this protocol, when we find objects in distance greater than 30cm then it will not sense, if the distance less than 30 cm then it will sense and create vibrations<sup>[1]</sup>. The same approach is also used in many applications. One is giving blind people the great accessibility to their environment is the objective of the smart glass system<sup>[2]</sup>. The key function of the another system is to enable the user in perceiving social signals during a natural dyadic conversation. Project's main goals are to improve navigation wearable system based on visual markers recognition and ultrasonic obstacles perception used as an vibrator assistance for blind people<sup>[3]</sup>. There was a solution for the blind people to walk safely by detecting obstacle and generating corresponding alert signal according to the distance of the obstacle<sup>[4]</sup>.

#### A Proposed Model

Blind as a special group in society, the needs of society to give them more care and attention, so that they are better able to live independently. However, how safe walking blind life is the biggest problem. Traditional navigation device mostly blind cane, blind by tapping the ground or walking around the object to determine the direction, the structure is simple, single function, easy to use, but the secondary effect is not very .blind such as poor road conditions, uneven, hanging in front of obstacles, can not be proven accurate, such a serious impact on the safety of blind travelers. A smart ultrasonic glasses for blind people comprises of a pair of wearable glasses, ultrasonic sensors for detection of obstacles in the way of blind man, a vibrator to give the vibrations as per the direction of the obstacle from the man, a central processing unit comprising of Arduino Nano which takes the information from the sensor about the obstacle distance and processes the information according to the coding done and sends the output through the vibrator, power supply is given to the central unit which distributes the power to different components. The sensor is mounted in between of the top bar, right and left and bridge present in optical glasses as shown in the figure 8. All the components are connected to the central unit using wires and the power is given from battery.

The best sensors that can be used will be ultrasonic sensors because ultrasound is a strong point, the energy consumption of slow wave propagating in the medium relatively far distance. Therefore often it is used to measure the distance over big length. At the same time, ultrasound for the object in the dark, dust, smoke, electromagnetic interference, toxic and other harsh environments have a certain ability to adapt, with a wide range of applications. The ultrasonic sensor is fixed at a perpendicular from the glasses. As the blind man goes closer to the obstacle the distance sent by the sensors to the central unit will decrease. Hence the vibrator will take shorter intervals and hence the vibration will be faster. But as the man will go far away the vibrations will take long intervals and hence decrease. These smart glasses are very easy to use and very simple to understand. If a blind uses it for 2-3 times then he/she will understand the working and can handle it easily<sup>[5]</sup>.

### 2. MATERIALS AND METHODS

#### 2.1 MATERIALS

For this project we have used the following components.

1. Arduino Uno.
2. Ultrasonic Sensor.
3. Vibration Motor.
4. Power supply.
5. Battery.
6. Spectacles .

The main component of this project is Arduino Uno, Ultrasonic sensor and Vibration motor.

The specification and purpose of each components are described below.

### 2.1.1. Arduino Uno

The Arduino is a open-source board based on the Microchip ATmega328P microcontroller and developed by Arduino.cc. The board is equipped with sets of digital and analog input/output (I/O) pins that may be interfaced to various expansion boards (shields) and other circuits. The board has 14 digital I/O pins (six capable of PWM output), 6 analog I/O pins, and is programmable with the Arduino IDE (Integrated Development Environment), via a type B USB cable. It can be powered by the USB cable or by an external 9-volt battery, though it accepts voltages between 7 and 20 volts. It is similar to the Arduino Nano and Leonardo.



FIGURE 1: Arduino Uno

### 2.1.2. Ultrasonic Sensor

Ultrasonic sensors are devices that generate or sense ultrasound energy. They can be divided into three broad categories: transmitters, receivers and transceivers. Transmitters convert electrical signals into ultrasound, receivers convert ultrasound into electrical signals, and transceivers can both transmit and receive ultrasound.



FIGURE 2: Ultrasonic sensor

### 2.1.3. Vibration Motor

Vibration motor is a DC motor in a compact size that is used to inform the users by vibrating on receiving signals. It has no sound. Mainly they are used in mobile phones, joysticks, pager and so on.



FIGURE 3: Vibration Motor

#### 2.1.4. Power Supply

A power supply is an electrical device that supplies electric power to an electrical load. The main purpose of a power supply is to convert electric current from a source to the correct voltage, current, and frequency to power the load. As a result, power supplies are sometimes referred to as electric power converters.



FIGURE 4: Power Supply

#### 2.1.5. Battery

An electric battery is a source of electric power consisting of one or more electrochemical cells with external connections for powering electrical devices.



FIGURE 5: Battery

#### 2.1.6. Spectacles

A wearable glass and all the components and wirings are attached on the glass.



FIGURE 6: Spectacles

### 2.2 SOFTWARE REQUIREMENTS

1. Arduino Ide.
2. Embedded.

### 2.3 METHODS

This smart ultrasonic glasses for blind people comprise of a pair of wearable glasses, ultrasonic sensors for detection of obstacles in the way of blind man, a vibrator to give the sound as per the direction of the obstacle from the man.

The best sensors that can be used will be ultrasonic sensors Often it is used to measure the distance over big length. at the same time, ultrasound for the object in the dark, dust, Smoke, electromagnetic interference, toxic and other harsh. Environment have a certain ability to adapt, with a wide range of applications.

The working of this device is quite simple, if an object is detected to the right, the right frame of the specs will vibrate. And vice versa. If object is detected to the center, both the frames will vibrate.



FIGURE 7: Algorithm

### 3. RESULTS AND DISCUSSION

The performance of the proposed system has found to be effective. The ultrasonic sensors can detect the obstacle and alert the user with a vibration. The proposed model is easy to wear and use and can be used as a portable model for visually impaired people.



FIGURE 8: Finished Model

### 4. CONCLUSION

The objective of this project is Third Eye for the Blind is to design a product which is very much useful to those people who are visually impaired and those who often have to rely on others. It is an innovation which helps the blind person to move around and go from one place to another with speed and confidence by knowing the nearby obstacles using the help of the wearable band which produces the ultrasonic waves which notify them with buzz sound or vibrations. It allows the user those who are visually impaired to walk freely by detecting the obstacles. They only need to wear this device as a band or cloth on their body.

### 6. REFERENCES

- [1]. "Obstacle Detection for Visually Impaired" by Ayush Wattal , In 2002, a group at Oxford developed a device that produced AR vision for people with severe peripheral vision loss.
- [2]. "A lightweight device to help visually impaired people", by a group of research from Munich, Mobile Computing Applications and Services (MobiCASE), 6th International Conference, 2015.
- [3]. "Smart Visibility Glasses for the Blind ", by Amogh Rane, Siddhesh Pujari, Gandhar Khopkar, Azhar Khan, Jyoti Dange in Electronics Components and Technology Conference (ECTC), 2016 IEEE 66th , 2016.
- [4]. " A lightweight device to help visually impaired people" By Alessandro Bissacco, Mark Cummins, Yuval Netzer and Hartmut Neven in Industrial Electronics (ISIE), 2013 IEEE International Symposium, 2013.
- [5]. "A new computer vision-based system", A group of researchers from Switzerland to help rollator users in 2014.
- [6]. "An alternative mobility aid for the blind :the ultrasoniccane", T.O.Hoydal, J.A.Zelano", in Bioengineering Conference Proceedings of the 1991 IEEE Seventeenth Annual NorthEast, 1991.

## DESIGN AND FABRICATION OF FINGER MILLET CUTTING MACHINE- A REVIEW

Akash H S<sup>1</sup>, Anand S<sup>1</sup>, Dhanush K<sup>1</sup>, Sanjay P<sup>1</sup>, Harish U<sup>2</sup>

<sup>1</sup>Students, <sup>2</sup>Assistant Professor  
Department of Mechanical Engineering  
K.S. Institute of Technology Bangalore -560109

### ABSTRACT

*This project addresses a crop cutting machine, which is fabricated with very simple mechanisms at low cost. Basically the Problems faced by farmers, who work on small fields, while harvesting is that, the crop takes a lot of time, the availability of labor and their cost during cutting season is also very high. Although various agricultural machines are available in the market but they are quite large and costly. It becomes uneconomical for small farmers to afford such kind of machines. In order to overcome the situation, we have introduced a new simple machine that is more efficient for small farmers. The design and working of a simple ragi cutting machine is discussed here, which is operated on the principle of slider crank mechanism by varying the length of cutting grains. And especially the machine targets the farmers who have land area of less than 2 acres. Hence this project might be the solution to the problems faced by a small scale farmer regarding cost and labor implementation.*

**Keywords:** Cutting Blades, Slider-Crank Mechanism, Dc Gear Motor, Battery

### 1. INTRODUCTION

Agriculture is the science and art of farming, including cultivating the soil, producing crops and raising livestock. Ragi is also known by the name finger millet. It is an important small millet food and fodder crop which is extensively cultivated in Asian countries like India, Malaysia, China and Nepal. In India finger millet is cultivated over an area of 1.19 million hectares with a production of 1.98 million ton giving an average productivity of 1661 kg per ha.

Harvesting is the process of gathering a crop. In ragi, harvesting refers to the cutting and gathering of earheads along the stalks. When the earheads turn brown color or at maturity stage, cut the earheads alone or cut the stalk along with ear heads by using sickles. The earheads are heaped in sun on the threshing floor for 1-4 days for drying, and then machine winnows and cleans the Ragi after threshing. The crop cutting is an important stage in agriculture field, over many years, agricultural practices have been carried out by smallholders cultivating between 1 to 2 hectare, using human labor and traditional tools such as wooden plough, yoke, leveler, harrow, mallet, spade, big sickle etc. Here we design and analyze the crop cutting machine which is to help the Indian farmer especially to small farm. It will reduce the cost of crop cutting in field. This machine cuts earheads separately and stores it. Due to this, farmer can feed straw to the domestic animal easily without any heavy efforts more over it is simple in design. It will help to increase the economical standard in Indian farmer.

### 2. COMPONENTS

#### 2.1 D C MOTOR



A DC motor is any of a class of rotary electrical motors that converts direct current electrical energy into mechanical energy.

## 2.2 BATTERY

Batteries convert chemical energy directly to electrical energy and stores it.



## 2.3 CUTTER BLADES

The pair of two cutters is used for cutting. One blade is stationary and the other is reciprocating. The thickness of blade is 2 mm and made up of MS plate.



## 2.4 BLOWER

Blower is a machine whose primary function is to provide and accommodate a large flow of air to various parts intern which will direct the flow by means of air by using this method the finger millet will be collected in collector this is achieved by rotating a number of blades connected to a hub a driven by a motor.



### 3. WORKING PRINCIPLE

For the motion of cutting mechanism of blades a simple "Slider-Crank Mechanism" is employed which has fixed blade, movable blade, rotating disk, rocker arm and coupler in which the fixed blade and moving blade has prismatic joint, coupler and rocker-

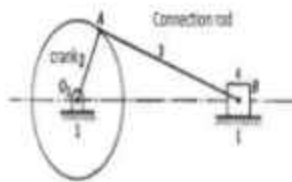

arm has revolute joint, the coupler and rotating disk has revolute joint and the rocker and moving blade has fixed joint. This mechanism is used to convert rotary motion into the reciprocating motion. This can be achieved by mounting the coupler off set from the center of rotating disk as shown in the Fig. In the the circle represents a rotating disk of thickness "t", radius "r" and "cs" represents the length of the coupler positioned off sated in rotating disk at a distance "r". When the coupler and the dotted line indicating distance "r" gets collinear at one end the minimum stroke and in the other end maximum stroke is achieved and thus the displacement "S" takes place For this mechanism, the power for driving the cutting mechanism, is transmitted from the motor with the help of the shaft which is connects motor and coupler. The motor which is running at a 60rpm, which gives rotary motion to coupler and then converted to linear motion, this motor is driven with electric battery of 6V

### 4. RESULTS AND DISCUSSION

For plot 1, since the plot was dense, it was difficult to cut. Supplied power was not sufficient to cut those dense areas. Also the efficiency of machine was poor. For plot 2, since plot was not dense but was inclined, it was comparatively easy to cut. Due to inclined nature of crops, machine pushed the crops so all crops were not cut properly which leads to decrease in efficiency of machine. But performance was comparatively better than that for plot 1. For plot 3, crops were straight. It was easy to cut lower part. In this plot we were also able to test upper cutter. With the motion of wheel, drum rotated and grabbed upper part of crops and cutter cut the lower portion While testing in all three plot, we also found that comparatively more power was required to push the machine which was due to the direct connection of wheel shaft with drum shaft by chain sprocket

### 5. CONCLUSION

The design and fabrication of finger millet cutting machine with selected constraints is completed successfully. The farmers can use this machine with upgraded cutter mechanisms that includead justing the height of the cutter for their desired level. This system is fabricated at the lower cost, which is approximately 60% less than the market value. This machine is operated manually using power source and hence maintenance is minimized, mean while the service can also be achieved easily and this can give a huge advantage to this equipment

### REFERENCE

- [1] Donny T ,Prabhakar P, Upadhyay C, CherianRandSureshAM(2012), Development of Working Prototype for Ragi Harvesting and Threshing Operation. International Journal of Scientific and Engineering Research.
- [2] Chowde Gowda M, Sreenatha A, Ramya H.N. and Jaymala G.B. ,2010. "Estimation of Energy Requirement for finger millet(EleusineG). Cultivation in Karnataka(India)". International Journal of Applied Agricultural Research.
- [3] Dr.Shailaja Hittalmani, "Development of high yielding, disease resistant, drought tolerant Fingermillet", University of Agricultural sciences, GKVK, Bangalore-560065, India, shailajah\_maslab @ rediffmail.com
- [4] A. Sreenatha, "Finger millet Harvesting and Threshing in Karnataka. A Case Study", Research Associate, Division of Agricultural Engineering, UAS, GKVK, Bangalore-560065, Karnataka, India.
- [5] Ojha T.P and Devnani 1987, Status of harvesting machinery in India—a country report, "Regional workshop on Design and Development of harvesting and Threshing Equipment", IARI, NewDelhi.
- [6] Chandrakantappa Kammar, Batagurki.S.B and Krishnappa.N, 2001, "Effect of Different Threshing methods on mechanical Damage and germination of finger millet".

**SOLAR POWERED AQUAPONICS SYSTEM**Chiranjeevi U<sup>1</sup>, Giridhar M P<sup>1</sup>, Prabhudev CM<sup>1</sup>, Manjunath B R<sup>2</sup><sup>1</sup> Students, <sup>2</sup> Associate ProfDepartment of Mechanical Engineering  
K.S. Institute of Technology Bangalore -560109**ABSTRACT**

*The most prevailing issues of the modern world are food and water crises. It is neither possible to consume the pesticide affected food nor grow one's own plants, due to scarcity of water and land. Under such conditions, there arises a need for portable agricultural system which uses less water, space and is purely organic. One such solution is a small scale aquaponic system. This system is made by introducing an automation and data acquisition system; thereby there is no need for setting aside extra time for system care. This paper has used the data acquired from an existing aquaponic system to design and implement an effective small scale sustainable aquaponic system. This can lead to cost effective, sustainable ways of organic farming independent of the need for comparable land space requirement.*

**Keywords:** Portable agricultural system, aquaponics, automation and data acquisition.

**1. INTRODUCTION**

The following paper contains the methodology to build a small scale aquaponic system suitable for different economic strata of the society especially focusing on the urban population where there is evident space and time constraints. This method contributes to one aspect of sustainable household development. In a small scale Aquaponic system, organic vegetables are cultivated in a limited space by recirculating water from a fish tank, rich in nutrients which are essential for the plant growth. Out of all the available water resources on planet Earth, 2.5% is freshwater resource. In this 2.5%, only 0.3% is the readily available freshwater resource accessible to humans. 70% of this limited amount of freshwater available is used for agriculture. Water scarcity already affects almost every continent and more than 40 percent of the people on our planet. By 2025, 1.8 billion people will be living in countries or regions with absolute water scarcity and two-thirds of the world's population would be living under water stressed conditions. In 2030, 47% of world population will be living in areas of high water stress. Most population growth will occur in developing countries, mainly in regions that are already experiencing water stress and in areas with limited access to safe drinking water and adequate sanitation facilities. Most of our food requires 100s of liters of water for production and adequate of per crop area for cultivation. The daily drinking water requirement per person is 2-4 liters, but it takes 2000 to 5000 liters of water to produce one person's daily food. In such a situation, a method like aquaponics which is the combination of hydroponics and aquaculture, can contribute effectively to the problem by lowering the amount of water usage for cultivation by 80% and also 75% of the area requirement.



2.

- one method production
- The two-in-effluents water filter
- Aquatic

- remains or natural waste matters of the fish raise in a fish tank.
- These effluents make the tank water develop toxicity which could be harmful to the fish therein, but these are nutrients vital to the growth of the plants in the aquaponic system.
- Hence, the system calls for a component that would remove the effluents and pump out the water into the grow bed for plants.
- Thus one of the major advantage of aquaponics is use of less water and spaces; producing less water waste and pollutants when compared to conventional method and using semi-skilled and local labour thus contributing to a sustainable livelihood.
- The fish waste provides 10 essential nutrients needed for plant growth out of the 13 nutrients.
- The fish waste decomposes to ammonia which is oxidized by nitrifying bacteria to give Nitrites which is further oxidized by nitrogen fixing bacteria to give Nitrates which can be absorbed by plants.

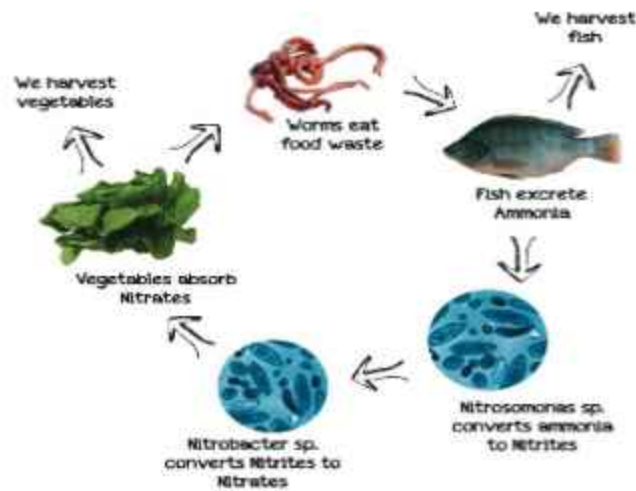

#### METHODOLOGY

- Aquaponics is of sustainable food system in one process, the that fish leaves in the make the latter grow. effluents refer to the

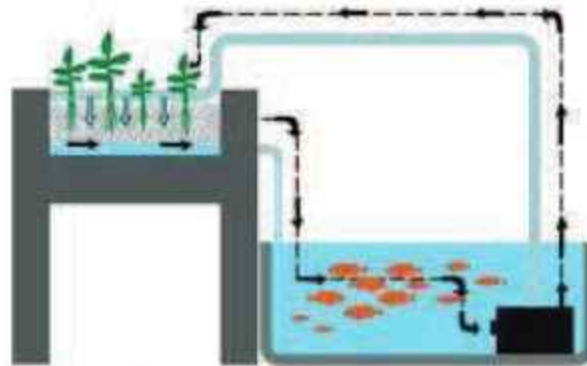

FIGURE 2: A traditional aquaponic system

### 3. COMPONENTS USED

TABLE 1: Components required and their specifications.

| SL No | Components Required |               |
|-------|---------------------|---------------|
|       | Component           | Specification |
|       |                     |               |

|    |                         |  |
|----|-------------------------|--|
| 1  | Aquarium                | 15-20 gallons                          |
| 2  | Grow bed                | 10 gallons capacity                    |
| 3  | Motor                   | Boyo 2500(any locally available motor) |
| 4  | PVC Tube                | 0.5 inches, 3 inches                   |
| 5  | Pipes                   | 0.5 inches(length as per requirement)  |
| 6  | Air pump, sponge filter | For 55l capacity                       |
| 7  | Arduino Microprocessor  | 8bit AVR microcontroller               |
| 8  | Temperature Sensor      |  |
| 9  | Humidity Sensor         |  |
| 10 | OxygenPercentage sensor |  |
| 11 | AuxiliaryBattery        | 12 V                                   |
| 12 | LCD display             |  |
| 13 | Solar Panel             | 36 cells                               |
| 14 | Timer relay             |  |

**The species of plants and fishes used into the system are:**

Aloe vera(Aloe vera),Cluster Beans(Cyamopsis tetragonoloba),Chilly(Capsicum frutescens),Ginger(Zingiber officinale), Onion(Allium cepa) in an area of 0.27meter square. Fish used: Tilapia(Oreochromis niloticus) Neem oil and tobacco mixed with water are the organic pesticides used in the system. The above mentioned system is the basic model of an aquaponics system which requires frequent pumping of water. This system is most suitable for common household where there is a person to supervise all day. The system can be further modified with a help of Arduino microcontroller board for switching ON and OFF the motor using time delay mode. This system can also be made more self-sustaining using solar power to harness the power required. Arduino is suggested for this purpose of automation because it provides a userfriendly interface and program can be learnt by any lay man. Moreover, solar power panels can be easily fixed by the farmers above the system as required

#### 4. CONCLUSION

Small scale aquaponic system is certainly the best solution for growing organic vegetables at homes in crowded cities as the space and water requirement for this system is less. It is an eco-friendly technology which can be improvised and made energy efficient at an individual's convenience and pattern of usage.

#### REFERENCES

- [1] Sylvia Bernstein, "Aquaponic Gardening a Step by Step Guide to Raising Vegetables and Fish Together," New society publishers.
- [2] Michael Sogaard Jorgensen, "Green Technology Foresight about Environmentally Friendly Products and Materials," A report submitted by Danish ministry of environment, report no. 34, 2006.
- [3] John Pade, "10 thoughts on system design," Aquaponics journal, Issue #46, 3<sup>rd</sup> quarter, 2007.

- [4] A.J. Both "Ten Years of Aquaponics Research," The State University of New Jersey.
- [5] Elisha R. Goodman "Aquaponics Community and Economic Development," Master in city planning at Massachusetts Institute of Technology, 2011.
- [6] Groov Elisa "Communal Aquaponic and Climatic Challenges," Master in Green Engineering at Californian Institute of Technology, 2011.
- [7] Nick Savidov, "Evaluation and development of product market capabilities in Alberta," Ids initiative fund final report, August 17, 2004.

## POWER ASSISTED POULTRY GARBAGE CHIPPING MACHINE

Amith Kumar M<sup>1</sup>, Jagadeesh Prasad S K<sup>1</sup>, Shashikiran A<sup>1</sup>, Nagabhushana M<sup>2</sup>

<sup>1</sup> Students, <sup>2</sup> Associate Professor  
Department of Mechanical Engineering  
K.S. Institute of Technology Bangalore -560109

### ABSTRACT

*This project is to design, implement of Poultry raking machine. The rapidly growing population has created some doubts in the said hypothesis. In fact, crop production alone may not solve the food problem of the country. The chief ingredients of balanced diet also comprise proteins, fats, minerals and vitamins, which are essential for growth. The supply of these items can easily be increased through increased production of livestock products. The present study has been undertaken to examine various aspects related to the growth and development of poultry production in the country.*

**Keywords:** Powered assisted poultry garbage, waste management, Variable Frequency Drive, Induction Motor

### 1. INTRODUCTION

Raking is necessary to keep poultry in good health. Due to scarcity of labour and efforts require for conditioning the litter, farmer faced problem for doing raking manually in poultry farm. We started thinking to mechanize it by developing a machine. We were able to develop the product called poultry raking machine.

It is being used for turning/disturbing the layers from bottom to top of poultry wastes accumulated in the farm. This exposes ammonia and nitrogen to atmosphere which is present in the animal wastes. Proper raking reduces the mortality rate of chicks and enhances the proper growth of chick by minimizing the disease spread.

### 2. MATERIALS

The components used in the poultry machine were as follows.

#### 2.1 Induction Motor



FIGURE 1: Induction Motor

An induction motor or asynchronous motor is an AC electric motor in which the electric current in the rotor needed to produce torque is obtained by electromagnetic induction from the magnetic field of the stator winding. An induction motor can therefore be made without electrical connections to the rotor. An induction motor's rotor can be either wound type or squirrel-cage type.

Three-phase squirrel-cage induction motors are widely used as industrial drives because they are self-starting, reliable and economical. Single-phase induction motors are used extensively for smaller loads, such as household appliances like fans. Although traditionally used in fixed-speed service variable-speed service, VFDs offer especially important energy savings opportunities for existing and prospective induction motors in variable-torque centrifugal fan, pump and compressor load applications. Squirrel-cage induction motors are very widely used in both fixed-speed and variable-frequency drive applications.

### 2.3 Variable Frequency Drive



FIGURE 2: VFD Drive

A variable-frequency drive (VFD; also termed adjustable-frequency drive, "variable-voltage/variable-frequency (VVVF) drive" is a type of adjustable-speed drive used in electro-mechanical drive systems to control AC motor speed and torque by varying motor input frequency and voltage.

VFDs are used in applications ranging from small appliances to large compressors. About 25% of the world's electrical energy is consumed by electric motors in industrial applications, which can be more efficient when using VFDs in centrifugal load service; however, VFDs' global market penetration for all applications is relatively small.

### 2.3 V-BELTS

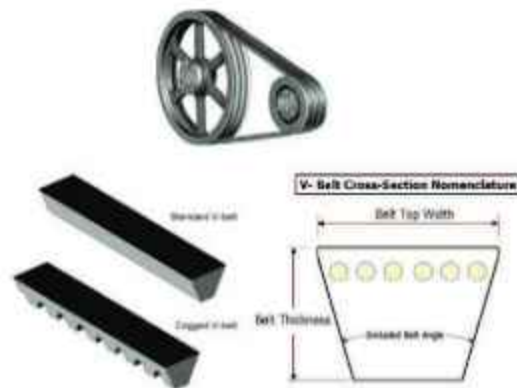

FIGURE 3: V Belt

V-belt (also called vee belt sheaves) are devices which transmit power between axles by the use of a v-belt, a mechanical linkage with a trapezoidal cross-section. Together these devices offer a high speed power transmission solution that is resistant to slipping and misalignment. V-belt pulleys are solely used for transmitting power between

two parallel axels. The most notable difference between a v-belt pulley and other types of pulleys (round belt, flat, etc.) would be the geometry of the groove or grooves located around the circumference of the pulley; these grooves guide and gain traction on a v-belt. The accompanying video offers a comprehensive overview of some v-belt basics, as well as their advantages and variations.

## 2.4 PULLEY



FIGURE 4:Pulley

A pulley is a wheel on an axle or shaft that is designed to support movement and change of direction of a taut cable or belt, or transfer of power between the shaft and cable or belt. In the case of a pulley supported by a frame or shell that does not transfer power to a shaft, but is used to guide the cable or exert a force, the supporting shell is called a block, and the pulley may be called a sheave. A pulley may have a groove or grooves between flanges around its circumference to locate the cable or belt. The drive element of a pulley system can be a rope, cable, belt, or chain.

## 2.5 SPEED CONTROLLER SWITCH



FIGURE 5: Speed Controller Switch

An electronic speed control follows a speed reference signal (derived from a throttle lever, joystick, or other manual input) and varies the switching rate of a network of field effect transistors (FETs) .[1] By adjusting the duty cycle or switching frequency of the transistors, the speed of the motor is changed. The rapid switching of the current flowing through the motor is what causes the motor itself to emit its characteristic high-pitched whine, especially noticeable at lower speeds. Different types of speed controls are required for brushed DC motors and brushless DC motors. A brushed motor can have its speed controlled by varying the voltage on its armature. (Industrially, motors with electromagnet field windings instead of permanent magnets can also have their speed controlled by adjusting the strength of the motor field current.) A brushless motor requires a different operating principle. The speed of the motor is varied by adjusting the timing of pulses of current delivered to the several windings of the motor.

## 2.6 Toggle Switch



FIGURE 6: Toggle Switch

A toggle switch is a graphical control element that allows the user to make a choice between two mutually exclusive states (such as on/off). Originally toggle switches were used primarily in touchscreen-based user interfaces, but they have later become commonplace in desktop and web applications. Toggle switches have a similar function as checkboxes, but unlike checkboxes, interacting with a toggle switch usually has an immediate effect on the application or system.

A toggle switch is a type of electrical switch that is actuated by moving a lever back and forth to open or close an electrical circuit. There are two basic types: maintained contact and momentary toggle switches. A maintained switch changes its position when actuated and will remain in that position until actuated again, such as an ON/OFF function. A momentary toggle switch is actuated only when someone is operating the switch. We design and manufacture a wide range of toggle switches with several mounting options. Our broad portfolio includes toggle switches with different actuator styles and amperage ranging from 3 to 20 amps, as well as different load-carrying capabilities and locking combinations. Further, we offer switches with and without guards to prevent accidental switching as well as individual switches and complete switch assemblies with additional sealed housings.

## 2.7 IDLER PULLEY



FIGURE 7: Idler Pulley

In a belt drive system, idlers are often used to alter the path of the belt, where a direct path would be impractical. Idler pulleys are also often used to press against the back of a pulley in order to increase the wrap angle (and thus contact area) of a belt against the working pulleys, increasing the force transfer capacity. Belt drive systems commonly incorporate one movable pulley which is spring- or gravity-loaded to act as a belt tensioner, to accommodate stretching of the belt due to temperature or wear. An idler wheel is usually used for this purpose, in order to avoid having to move the power transfer shafts.

## 2.8 Dead Shaft Idler Rolls



FIGURE 8: Dead Shaft Idler Pulley

With a Dead shaft idler, bearings are installed in each end of the roller body and the shaft passes through the body of the roll. The shaft is mounted to the framework of a machine and the roll body rotates around the fixed shaft. The shaft does not rotate so it is called a dead shaft.

## 2.9 Chassis:



FIGURE 9. Chassis

A chassis is the load-bearing framework of an artificial object, which structurally supports the object in its construction and function. An example of a chassis is a vehicle frame, the underpart of a motor vehicle, on which the body is mounted; if the running gear such as wheels and transmission, and sometimes even the driver's seat, are included, then the assembly is described as a rolling chassis.

## 2.10 COVER:





FIGURE 10. Cover

A cover is often a structural system that supports other components of a physical construction. The cover is design to cover the internal parts of machine. It is fabricated using sheet metal to cover internal parts from dust can also provide protection for some internal part.

### 2.11 Chipping Blades:

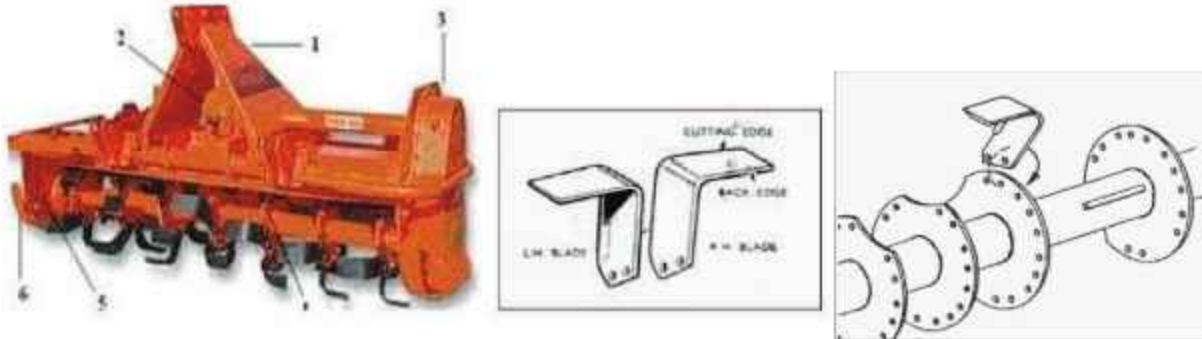

FIGURE 11. Chipping Blades

The rotavator is a tillage tool primarily comprising of L-shape blades mounted on flanges that are fixed to a shaft and it is driven by the tractor power-take-off (PTO) shaft. In comparison to passive tools, the rotavator has a superior soil mixing and pulverization capability. During rotavator tillage operations various factors affect its energy requirements. These factors can include soil conditions, operational conditions and rotavator configuration.

### 2.12 Roller Coaster Wheels:



FIGURE 12. Roller Coaster Wheel

Today's modern roller coasters, both wooden and steel, have the same basic design of wheel assembly. Each wheel assembly has three wheels: under friction, or up-stop, wheels; tractor, or running, wheels; and side friction wheels. All of these help the train move safely and smoothly. All modern roller coasters have up-stop wheels that hug the bottom of the rail. As their name implies, they prevent the train from coming up off the track. Side friction wheels hug the sides of the rail, either the outside or inside, depending on the track manufacturer. These wheels help the train stay in the center of the two rails to keep the train from derailing. The last wheel set are called tractor wheels, or running wheels. Tractor wheels have a simple but important purpose. These wheels bear the weight of the train on the track, keeping the train running on the track. Tractor wheels may lift off the track in when the vertical g-force is zero or negative, but the up-stop wheels keep the train from coming completely off the rails.

### 3. FABRICATION PROCESS

Operation involved in manufacturing poultry garbage chipping machine:

- Marking
- Metal cutting
- Drilling
- Turning
- Welding
- Grinding
- Buffing
- Painting

### 4. CONCLUSIONS

A machine was built and tested. The machine is capable of cleaning a poultry shed area of 5000 sqft per hour. Certain problems (higher stress generation) were observed in the process in the blade. This was sorted out by increasing the thickness of the plate( present thickness of blade is 4mm)

- Initially EN8 was used for blade material and later material was changed to EN24 Steel due to its high strength which gives longer life compared to EN8.
  - The load condition is applied for existing and modified design blades.
  - EN24 material is producing lesser stress compared to EN8.
- Also EN24 can give better wear resistance compared to EN8 which is a key parameter for longer life of the blade.

### ACKNOWLEDGMENTS

We would like to express our gratitude to our project guide **Mr. Nagabhushana M, Associate professor** and also express our gratitude to **Dr. Nirmala L, Student Project Coordinator**, for having given this opportunity and support to carry out our project work.

### REFERENCES

- [1] Godwin R.J, O "Dogherty" M.J (2006) "Integrated soil tillage force prediction models" Vol. 44, pp. 3-14.
- [2] Gopal U. Shinde and Shyam R. Kajale (2012) Design optimization in rotary tillage tool system components by CAEA Vol. 3, No. 3, pp. 279-282.
- [3] Khalid Usman, Ejaz Ahmad Khan, Niamatullah Khan (2013) Effect of Tillage and Nitrogen on Wheat Production, Economics, and Soil Fertility in Rice-Wheat Cropping System Vol. 4, pp. 17-25.
- [4] Mahesh M. Sonekar I, Dr. Santosh B. Jaju (2011) Fracture analysis of exhaust Manifold stud of Mahindra Tractor through finite Element method (FEM) – a past Review Vol. 3, pp. 131-135.
- [5] Rahul Davis (2012) Optimization of surface roughness in wet turning operation of EN24 steel Vol. 2, Issue 3, pp. 28-35.
- [6] Rahul Davis, Jitendra Singh Madhukar (2012) A parametric analysis and optimization of tool life in dry turning of en24 steel using taguchi method Vol. 3, Issue 1, pp. 9-15.
- [7] Subrata Kr. Mandal and Basudeb Bhattacharyya (2013) Design &Development of rotavator blade: Interrogation of CAD method" Vol. 1, No. 10, pp. 439-447.
- [8] Venkatasiva S.B, Srinivasarao G, Mahesh kumar M(2012) Study of phase transformations in EN8 steel material using acoustic emission technique Vol. 1, pp. 541-550.
- [9] Zarroug.N.M, Padmanabhan.R, MacDonald.B.J, Young.P, Hashmi.M.S.J (2003) Mild steel (EN8) rod tests under combined tension–torsion loading Vol. 143.

## DESIGN AND FABRICATION OF A SEMI-AUTOMATIC PNEUMATIC INJECTION MOLDING MACHINE

Yateesh H Jamadade<sup>1</sup>, A.K. Aditya<sup>1</sup>, Nihal M Poojary<sup>1</sup>, Akhil Purohith<sup>1</sup>, Parashuram A.K<sup>2</sup>

<sup>1</sup> Students, <sup>2</sup> Associate Professor  
Department of Mechanical Engineering  
K.S. Institute of Technology Bangalore -560109

### ABSTRACT

*In this study, a concept of low cost injection molding system is presented. A prototype of a vertical injection molding machine has been designed and built based on the basic principles of injection molding. The developed system consists of plunger, melting chamber and custom-made mold. The plunger is used to deliver plastic melt from the melting chamber into the specific shape of the mold cavity. The performance of the custom-made machine is tested by successfully fabricated tensile specimen, Izod specimen, microchannels and gear shapes. The machine is capable of producing plastic parts of various shapes and sizes.*

**Keywords:** Injection Moulding, Pneumatic.

### 1. INTRODUCTION

Injection Moulding is a manufacturing process for producing parts from both thermoplastic and thermosetting plastic materials. Material is fed into a heated barrel, mixed, and forced into a mold cavity where it cools and hardens to the configuration of the mold cavity. The plastic injection moulding industry has evolved over the years from producing combs and buttons to producing a vast array of products for many industries including automotive, medical, aerospace and consumer products. The Machine parts analysis using feature based methodology. This approach allows robust design of part components. This is also useful for parting plane and product layout.

### 2. MACHINE COMPONENTS

The pneumatic Moulding Machine Consist of various components. The Machine is mainly divided into two units –Injection unit & Clamping Unit. Injection Unit having components are Cylinder, Barrel, Screw, Backflow Prevention Valve, Nozzle & Heater. Clamping unit consist of Clamp, Exhaust Valve & Die Assembly parts.

**Injection Cylinder:** There are many types of injection cylinders that supply necessary power to inject resins according to the characteristics of resins and product types at appropriate speed and pressure. This model employs the double cylinder type. Injection cylinder is composed of cylinder body, piston, and piston load. [5] Design of Cylinder consist of – (a) Cylinder Thrust (b) Air Consumption (c) Mounting



**Barrel:** Nitride Steel barrel are used for Iupilon /Novarex plastic resins is good. The Barrel consists of cooling water channel, heater bands, Thermocouple whose function is to note the temperature in various section of barrel. The time it takes for the plastic material from entering the barrel to the nozzle is called the residence time [6]

**Nozzle:** Nozzle is located at the end of barrel which provides melt can leave barrel and enter into the mould. melt can be heated here by friction and conduction from a heater band before entering the relatively cold channels in the mould. Contact with the mould causes heat transfer from the nozzle and in cases where it is excessive it is advisable to withdraw the nozzle from the mould during the screw-back part in the moulding cycle. Otherwise the plastic may freeze-off in the nozzle [6].

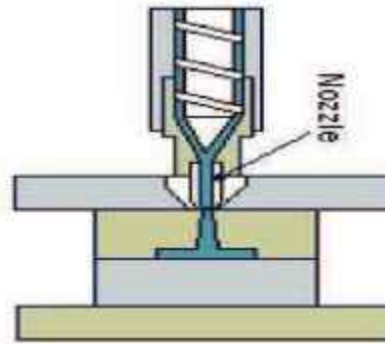

**Clamp Mechanism:**Clamping is used to keep the mould tightly closed under sufficient pressure to let the molten plastic fill in the cavity without leaking during the injection process.

**Heater:** The Plastic resins are moulded at high temperature. the heater with heat capacity can be heated to about 150-350°C is used, and a band heater is usually used.

**Collar/Hopper:** Collar is the channel along with the molten plastic first enters the mould through the cylinder pipes. It delivers the melt from the nozzle to the runner system.



**Direction Control Valve( 5/2 DCV):** DCV are one of the most fundamental parts of hydraulic and pneumatic systems. DCVs allow fluid flow (hydraulic oil, water or air) into different paths from one or more sources. DCVs will usually consist of a spool inside a cylinder which is mechanically or electrically actuated. The position of the spool restricts or permits flow, thus it controls the fluid flow.

**Base:** It's the base of the machine which provides stability to the whole machine structure. Its helps in anchoring the machine , it also houses the clamping mechanism.**RL Unit:** Filter, regulator, and lubricator (FRL) compressed air systems are used to deliver clean air, at a fixed pressure, and lubricated (if needed) to ensure proper pneumatic component operation and increase their operation lifetime

**PNEUMATIC SWITCH:** The pneumatic switch actually starts the manufacturing process by sending the start signal to the control unit.

**DIE:** A die is usually made in two halves and when closed it forms a cavity similar to casting desired. One half of the die remains stationary is known as "cover die" and the other movable half is called "ejector die".

### 3. ASSEMBLING OF MACHINE

Machine cannot create energy by itself. Therefore machine requires prime mover. In most of machines prime mover is an electric motor 3 phase induction motor in case of injection moulding machine. In this machine electrical energy is converted into mechanical energy by using pneumatic compressed system. For the Pneumatic compression injection Cylinder is used. FRL unit is used for filtration, regulation and lubrication of the compressed air. Temperature sensors is used for controlling the temperature of dies, asbestos and glass wool for

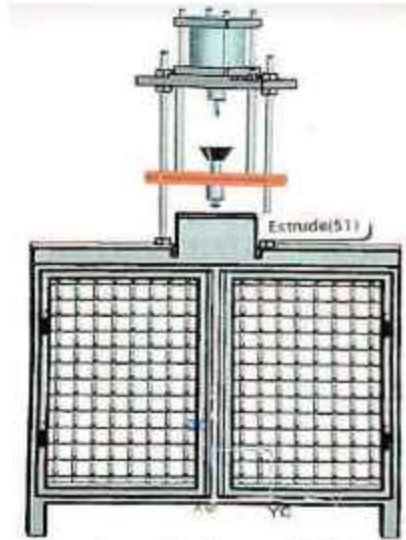

the insulation between piston rod and dies, a frame is used for the equal distribution of load on the material to be produced by using this machine. Molding compound is placed in an open and heated mold cavity. The mold is closed and the pressure is applied to force the material to fill up the entire mold cavity. The heat and pressure is maintained until the plastic material is cured. Once the material is cured it is removed from the mold for finishing.

### 4. CONCLUSION

Designing of machine components are considered as a very important task now a days The machine is designed and developed at comparable low cost and pneumatic systems are easy to maintain as the working fluid is air , the environment around the machine is contamination free compared to hydraulic version of the machine .

### REFERENCES

- [1]Pravin popatrao Shinde, S S Patil, Swapnil S Kulkarni "Design & Development of Plastic Injection mould for auto components" in International Journal of Advanced Engineering Research and Studies, Vol. 4 Issue 1 Oct-Dec. 2014, Pages 27-30.
- [2]L.M. Galantucci, R Spina, " Evaluation of filling conditions of injection moulding by integrating numerical simulation and experimental tests" in ELSEVIER-Journal of Material processing & Technology, 141(2003) Pages 266-275.
- [3]Sharifah Imihezri Syed Shahrudin, Mohd. Sapuan Salit,Edi Syams Zainudin, "A review of the effect of Moulding parameters on the Performance of polymeric composite injection Moulding" Turkish J Engg. Env. Sci., 30, 2006, Pages 23-34.
- [4]Eranna H, "Development of Pneumatically operated compression Moulding Machine" in International Journal of Engineering Research, Vol.2 Issue 4 oct. 2014, Pages 62-67.
- [5]Poonam G Shukla, Gaurav p Shukla, "Design & Fabrication of Pneumatically operated injection Moulding Machine, in International Journal of Engineering & innovative Technology (IJEIT), Vol. 2, Issue 7, January 2013, Pages 98-101.

[6]Crawford, R., 1998. Plastic Engineering, 3rd ed. Oxford: Butterworth – Heine-mann.

## EXPERIMENTAL & NUMERICAL INVESTIGATION ON VIBRO-ACOUSTIC BEHAVIOUR OF THIN CYLINDRICAL SHELLS

<sup>1</sup>Rakshith A, <sup>1</sup>Sanjay Rao G, <sup>1</sup>Srinivas R, <sup>1</sup>D Manish, <sup>2</sup>Mr. Anil Kumar A

<sup>1</sup>Students, <sup>2</sup>Assistant Professor  
Department of Mechanical Engineering  
K.S.Institute of Technology, Bengaluru, Karnataka, India

### ABSTRACT

*Vibrations are the engineering complexity that we are facing in our daily life, which is undesirable based on their occurrence and the circumstance. Vibrations will have adverse effects on durability, life and loss of characteristics among other effects on the machine part/component. This must be avoided or controlled because, if the vibrations exceed a certain point, the component will fail due to the phenomenon of resonance. This paper deals with vibrations and acoustics behaviour of thin cylindrical shells of very large radius of curvature, which finds its applications in the field of automobiles, aerospace and etc. In this work an investigation on natural frequency of thin cylindrical shell structures were carried out experimentally for CRC steel with and without internal voids. The shell element of different radii of curvature (1000mm, 1500mm, 2000mm) were fabricated and tested under different boundary conditions. The modal frequencies and modal spectrums of the thin cylindrical shells are investigated by experimental methods.*

**Keywords:** Natural frequency, Internal voids, Shells, Radius of Curvature, Boundary Condition, Modal Frequencies.

### 1. INTRODUCTION

A shell is a type of structural element which is characterized by its geometry, the term shell is applied to bodies bounded by two curved surfaces, where distance between the surfaces is small in comparison with other body dimensions. ( Depending on curvature of surface, shells are divided into cylindrical, conical, spherical, ellipsoidal shells. There are different classes of shells, thick shells and thin shells. A shell is called thin if maximum value of  $h/R$  ( $h$ -thickness and  $R$ -Radius of curvature of middle surface) is  $\max(h/R) \leq 0.05$ . If shells for which this condition is violated are referred to as thick shells. For a large number of practical application thickness of shell lies in the range  $0.001 \leq h/R \leq 0.05$  i.e., in the range of thin shells[1]. Thin walled, cylindrical structures are found extensively in both engineering components and in nature.

Any motion that repeats itself after certain interval of time is called vibrations. Vibrations occurs when system is displaced from the position of equilibrium. All bodies having masses and elasticity are capable of vibrating. When the frequency of the external excitation equals to the natural frequency of the system, the system response to it with increased amplitude. This condition is called resonance and frequency is called resonant frequency. Vibrations is harmful in mechanical system because of noise, high amplitude of vibration at resonant condition and damage to the machine component. So, in vibration engineering the goal is to remove bad vibration or reducing the amplitude of vibration. A commonly practiced method for reducing unwanted vibration and radiated noise from a structure is the implementation of passive constrained layer damping treatment due to its effectiveness and cost efficiency. Information regarding the effects of such damping treatments is still sparse and the techniques for application are still empirical, though some works have investigated mathematically derived optimization techniques for patch placement on plate [2]

This paper focuses on the vibration and damping analysis of three-layered sandwich cylindrical shells with stiff steel face layers and a viscoelastic core. Then, impact hammer method was used to study the natural frequencies of the cylindrical shell structures of radius of curvature 1000mm, 1500mm & 2000mm, subjected to Free-Free (FF), Cantilever condition(FFFC), Two sides fixed (FCFC) & all sides fixed (CCCC) boundary conditions. Also the acoustic behaviour was recorded by using the near field approach.[3]

### 2. MATERIALS AND METHODS

As steel is the commonly used material in automobiles & aerospace structure, the present paper focuses on the Vibro-acoustic behaviour of steel panels. Cold rolled steel sheets offer variety of outstanding properties including

easy formability and a smooth clean surface and has minimal deviation in mechanical properties. These are best suited for automobile electrical appliances due to high strength and improved formability. Due to the good properties and formability of CRC sheets, this material was apt for our requirements. The long CRC sheets were cut to the required dimensions with the help of hydraulic cutting machine, the CRC sheets were rolled with the help of rolling machines. And also, to mount the sides of the shell structure on the fixture for testing, the sides of the specimen were flattened with the help of bending machine.



FIGURE1: Cutting & rolling of CRC Steel sheets

For dampening the vibration effect of the shell structures, a perforated sheet made up of the same material was sandwiched between a pair of rolled CRC sheets. In order to sandwich the layers, the material was cleaned with the help of emery paper and thinner to remove the dirt and grease. Then the sheets were glued with the help of Bond Tite–Ametaltometal glue manufactured by Astral Adhesives and the fabricated shell structures are as shown in Fig2. Dimensions of the shell structures are as shown in Table1.

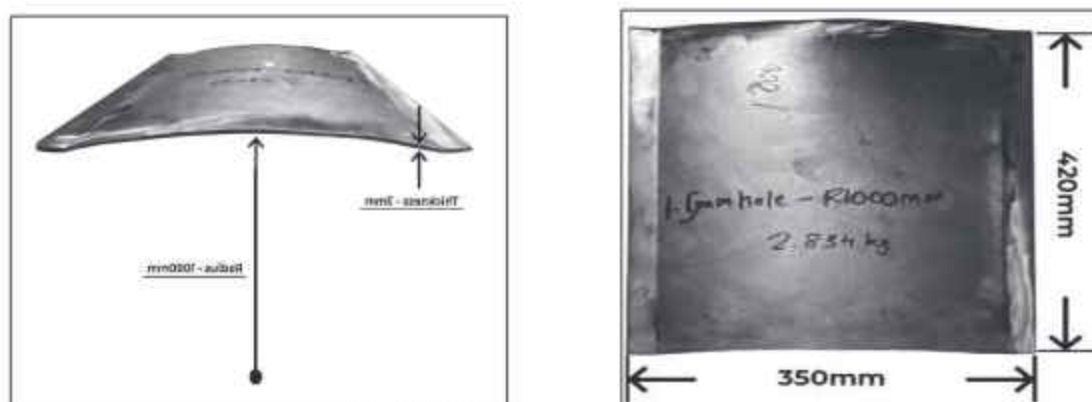

FIGURE2: Fabricated shell structures.

TABLE 1: Dimensions of the Shell Structure.

| SL.No | Thickness (h) | Radius of Curvature (R) | (h/R) ratio |
|-------|---------------|-------------------------|-------------|
| 1     | 3mm           | 1000mm                  | 0.003       |
| 2     | 3mm           | 1500mm                  | 0.002       |
| 3     | 33mm          | 2000mm                  | 0.0015      |



### 3. EXPERIMENTATION

The natural frequencies of the cylindrical shell was found using the impact hammer method. In this method the specimen was rigidly clamped to the fixture and an accelerometer was fixed to the specimen to capture the vibrations from the specimen, when it is excited by the hammer. The mechanical signals generated because of the impact force from the hammer was captured and transmitted to the FFT analyser, where the mechanical signals are converted to electrical signals. Finally the results were fed in to the computer and analysed by using Simens Multi-channel Data Acquisition System LMS test labs software as shown in fig3.

FIGURE 3: Experimental setup of Impact hammer method



### 4. RESULTS

The impact hammer method was used to find natural frequencies of the cylindrical shell structures of 1000mm, 1500mm & 2000mm radius of curvature & with no voids, 1mm internal voids and 1.5mm internal voids, subjected to the FF, CCCF, CFCF, CCCC boundary conditions. The variation of natural frequencies with boundary conditions and radius of curvature is as shown in Table2-Table4. From the tables it is clearly seen that shells under all sides fixed ( CCCC) boundary conditions exhibits higher natural frequencies, because as the shells are fixed on all the sides increases stiffness, which intern increases natural frequency. And also shells with 1.5mm voids and 2000mm radius of curvature exhibits better vibration charecteristics.

TABLE 2: Natural frequencies of Cylindrical shell with no voids subjected to FF, CCCF, CFCF, CCCC boundary conditions

#### Comparison with respect to Radius of Curvature (No Internal Void)

| Condition \ Radius | Free Free | Cantilever | Two Sides Fixed | All Side Fixed |
|--------------------|-----------|------------|-----------------|----------------|
| R1000              | 127       | 26         | 207             | 250            |
|                    | 460       | 151        | 465             | 518            |
|                    | 698       | 711        | 752             | 814            |
| R1500              | 196       | 150        | 214             | 254            |
|                    | 702       | 711        | 611             | 381            |
|                    | 896       | -          | 786             | 684            |
| R2000              | 127       | 140        | 424             | 243            |
|                    | 367       | 365        | 668             | 429            |
|                    | 829       | 6922       | 826             | 634            |

**TABLE 3:** Natural frequencies of Cylindrical shell with 1mm voids subjected to FF, CCCF, CFCF, CCCC boundary conditions

| Condition \ Radius | Free Free | Cantilever | Two Sides Fixed | All Side Fixed |
|--------------------|-----------|------------|-----------------|----------------|
| R1000              | 151       | 16         | 348             | 374            |
|                    | 288       | 189        | 389             | 414            |
|                    | -         | -          | -               | 704            |
| R1500              | 16        | 14         | 316             | 358            |
|                    | 295       | 197        | 527             | 697            |
|                    | 570       | -          | 732             | 733            |
| R2000              | 161       | 19         | 251             | 344            |
|                    | 505       | 68         | 497             | 362            |
|                    | -         | 189        | 885             | 491            |

**TABLE 4:** Natural frequencies of Cylindrical shell with 1.5mm voids subjected to FF, CCCF, CFCF, CCCC boundary conditions

| Condition \ Radius | Free Free | Cantilever | Two Sides Fixed | All Side Fixed |
|--------------------|-----------|------------|-----------------|----------------|
| R1000              | 165       | 21         | 388             | 428            |
|                    | 277       | 199        | 578             | 447            |
|                    | 610       | -          | 734             | 755            |
| R1500              | 108       | 17         | 276             | 338            |
|                    | 133       | 168        | 543             | 366            |
|                    | 463       | -          | 905             | 627            |
| R2000              | 140       | 17         | 260             | 411            |
|                    | 306       | 172        | 650             | 436            |
|                    | -         | 209        | -               | 720            |

As the vibrations induces noise also the noise emitted from the cylindrical shell structure was found out and the variation of noise emitted from the shell structures in as shown in Table5-Table7. From the tables it is clearly seen that shells with 1mm and 1.5mm holes exhibits better acoustic properties.

**TABLE 5:** Noise radiated from a cylindrical shell of 1000mm radius of curvature with no voids, 1mm voids and 1.5mm voids.

| Condition \ Voids | Free-Free | Cantilever | Two Sides Fixed | All Side Fixed |
|-------------------|-----------|------------|-----------------|----------------|
| No voids          | 59.8      | 57.3       | 50.5            | 50.9           |
| 1mm voids         | 52.5      | 52.6       | 51.9            | 55.1           |
| 1.5mm voids       | 50.9      | 51.3       | 47.3            | 33.6           |

**TABLE 6:** Noise radiated from a cylindrical shell of 1500mm radius of curvature with no voids, 1mm voids and 1.5mm voids.

| Condition \ Voids | Free-Free | Cantilever | Two Sides Fixed | All Side Fixed |
|-------------------|-----------|------------|-----------------|----------------|
| No voids          | 42.3      | 43.4       | 49.9            | 48.3           |
| 1mm voids         | 51.7      | 52.1       | 43              | 44             |
| 1.5mm voids       | 51.8      | 51.2       | 49.1            | 50.6           |

**TABLE 7:** Noise radiated from a cylindrical shell of 2000mm radius of curvature with no voids, 1mm voids and 1.5mm voids.

| Condition \ Voids | Free-Free | Cantilever | Two Sides Fixed | All Side Fixed |
|-------------------|-----------|------------|-----------------|----------------|
| No voids          | 57.3      | 51.6       | 53.6            | 52.5           |
| 1mm voids         | 50        | 49.7       | 51.6            | 50.4           |
| 1.5mm voids       | 53.2      | 42.3       | 47.6            | 52.3           |

## 5. CONCLUSIONS

From the present study the following conclusions can be drawn

- Thin cylindrical shells of CRC Steel Sheet of different radii of curvature (1000mm, 1500 mm, 2000 mm) with and without internal voids (1mm, 1.5mm) were fabricated.
- Dynamic analysis of these cylindrical shell structures was carried out for four different boundary conditions i.e., all sides fixed Boundary condition, two sides fixed, free boundary condition, Cantilever Condition, Free Free/Hanging Condition using Impact Hammer method.
- As the stiffness increases in all sides fixed boundary condition when compared to other boundary conditions, shell structure with All sides fixed boundary condition exhibited higher frequency than that of other boundary conditions.
- From experimentation it is found that the cylindrical shell structure with 1mm & 1.5mm Internal Voids exhibited higher natural frequency than cylindrical shell structure without any Internal Voids due to damping effect.
- We can conclude that the natural frequency increases with an increase in radius of curvature of the shell structure, as the radius increases the stiffness of the shell structure decreases and behaves like a plate.

## REFERENCES

- [1] Mayur Vekariya, Ashish H. Makwana, Head & Assistant Professor, Civil Engineering department., Pacific School of Engineering, V: Sanki, Ta. Palsana, Surat-394305, Gujarat, India Planning Engineer, Tata Projects Ltd., Ahmedabad-380051, Gujarat, India.
- [2] Matthew A. Dawson, Lorna J. Gibson b a Department of Mechanical Engineering, Massachusetts Institute of Technology, Cambridge, MA 02139, United States.
- [3] Erdem Yuksel, Gulsen Kamci and Ipek BasdoganKoc University; Mechanical Engineering Department, Sariyer, Istanbul, 34450, Turkey.
- [4] Xianzhong Wanga, Di Chen, Yeping Xiang, Weiguo Wau 2211-3797/ © 2019 The Authors. Published by Elsevier B.V. This is an open access article under the CC BY-NC-ND license.
- [5] C.A. Dimopoulos n, C.J. Gantes Metal Structures Laboratory, School of Civil Engineering, National Technical University of Athens, Greece.
- [6] Materials Science, Vol. 55, No. 4, January, 2020 (Ukrainian Original Vol. 55, No. 4, July–August, 2019) DOI 10.1007/s11003-020-00331-2.
- [7] Journal of Mathematical Sciences, volume 2 ,1072-3374/11/1742–0254, A.Ya. Grigorenko, S.V. Puzyrev, A.P. Prigoda and V.V. Khorishko.

## EFFECT OF COMBINATION OF ETHANOL INJECTION AND AFTER TREATMENT DEVICES ON DIESEL ENGINE EMISSION- A REVIEW

<sup>1</sup> Nithin kumar , <sup>2</sup> Pavan kumar , <sup>3</sup> Santhosh K, <sup>4</sup> Sohith S, <sup>5</sup> Nagaprasad K S

<sup>1 2 3 4</sup> UG-students, <sup>5</sup> Associate Professor  
Department of Mechanical Engineering  
K.S. Institute of Technology Bangalore -560109

### ABSTRACT

*Internal combustion engine is established as the main power source for automobile vehicles. At present emission norms becomes strict for any I.C. Engine. The main pollutant is CO, HC, NOx, PM, soot, etc. The aim of this work is to inject Ethanol to reduce the emission norms like CO, HC, NOx, PM, soot and by using after treatment devices.*

*Experiments were conducted on a four stroke water cooled single cylinder, compression ignition engine. All tests were conducted at different loads . At 0kg, 3kg, 6kg, 9kg, 12.5kg load. The engine speed is maintained constant at 1500 rpm. Diesel engine was running at 1500 rpm, rated power 3.5 KW, Compression ratio 18:1.*

**Keywords:** Diesel Engine ,Diesel Particulate Filter(DPF), Catalytic Convertor(CC),Engine Emissions

### 1. INTRODUCTION

Diesel engine is an interior burning engine where in start of the fuel is brought about by the raised temperature of the air in the chamber because of the mechanical pressure. Diesel engines works by packing just the air. This builds the air temperature inside the chamber to such a serious level that atomized diesel fuel infused into the burning chamber lights suddenly. In any case, the issue with diesel engine is its higher pace of contamination discharges. Among the fundamental contaminations Nitrogen Oxides (NOx), Carbon Monoxide (CO), Hydrocarbons (HC), Particulate Matter (PM), Carbon Dioxide (CO<sub>2</sub>), Sulphur Dioxide (SO<sub>2</sub>), aldehydes most unsafe poisons of diesel engine are NOx and PM. To adapt to the exacting discharge standard, green engine which diminishes exhaust emanation ought to be created. Execution of after-treatment frameworks like Diesel particulate channel (DPF), incite critical increase in outflows decrease were attempted. Diesel particulate channels (DPF) is the gadgets that truly catch diesel particulate matter in the Fumes line to forestall the Delivery to the Climate.

### 2. DIESEL ENGINE

A 4-stroke engine is a very common variation of an internal combustion engine. Most modern internal combustion-powered vehicles are 4-strokes, powered by either gasoline or diesel fuel. During engine operation, pistons go through 4 events to achieve each power cycle. The definition of an event is an up or down piston motion. Upon completion of the 4 events, the cycle is complete and ready to begin again. 4-stroke engines deliver a good balance of power, reliability and efficiency. When it comes to emissions, 4-strokes separate each event mechanically, which reduces unburned fuel emissions. It also separates oil from fuel, which significantly reduces carbon monoxide emissions. This combination of desirable traits has earned the 4-stroke the top spot in passenger vehicles today.



FIGURE 1. Diesel Engine

### 3. DIESEL PARTICULATE FILTER

The particulate filter consists of a porous ceramic (silicon carbide). It has a honeycomb-like structure with a large number of channels that are alternately closed at their ends so that the exhaust gas flow is forced to pass through the fine pores of the filter walls, the gaseous substances can pass through without any problems, whereby the much larger soot particles and other solids are retained on the partition walls deposit on the wall surfaces.

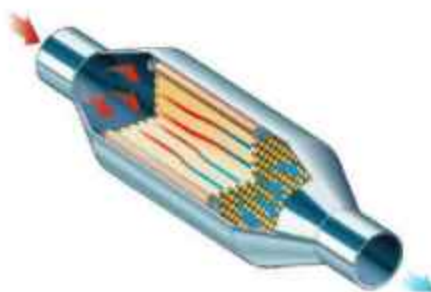

FIGURE 2. Diesel Particulate Filter

### 4. CATALYTIC CONVERTER

As emission regulations have tightened, the complexity of the catalytic converter system has increased. Meeting the demands of tightening legislation may require increased converter volume, translating into the use of multiple catalytic converter elements within a vehicle exhaust system.

Components used in this work consisted of Cordierite flow-through monoliths wash coated with alumina and platinum catalyst as well as Pt/Pd which provides low temperature T50 values for CO and HC. But in the case of under floor catalytic converter, which is widely used for many years because of convince of packaging as its catalyst. In order to reduce this delay, and to increase the efficiency of the catalyst at low temperature, the improvement in wash coat formulation is introduced with the help of new precious metals such as Pt/Pd

Oxidation of carbon monoxide to carbon dioxide:

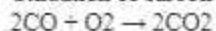

Oxidation of hydrocarbons (unburned and partially burned Fuel) to carbon dioxide and water:

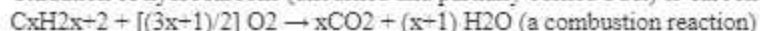

### 5. TEST PREPARATION

The setup consists of single cylinder, four stroke, Diesel engine connected to eddy current dynamometer for loading. It is provided with necessary instruments for combustion pressure and crank-angle measurements. These signals are interfaced to computer through engine indicator for PV diagrams. Provision is also made for interfacing airflow, fuel flow, temperatures and load measurement. The set up has stand-alone panel box consisting of air box, fuel tank, manometer, fuel measuring unit, transmitters for air and fuel flow measurements, process indicator and engine indicator. Rota meters are provided for cooling water and calorimeter water flow measurement.

When the engine is started the diesel is supplied to the combustion chamber directly and the ethanol is supplied to the engine by Time Valve at different time intervals like 2millisec, 3 millisec, 4 millisec, 5 millisecond using manifold injection with help of ECU. The emission of the engine is tested for different loads at different time intervals.

| PROPERTIES                              | ETHANOL               | Diesel |
|---|-----------------------|--------|
| Density (kg/m <sup>3</sup> )            | 789                   | 816    |
| Kinematic viscosity (m <sup>2</sup> /s) | 1.52*10 <sup>-6</sup> | 2.20   |
| Flash point (°C)                        | 12.7                  | 48     |
| Fire point (°C)                         | 63                    | 55     |
| Calorific value (MJ/kg)                 | 29.78                 | 45.66  |
| Pour point                              | -10                   | -9     |
| Total acidity (mg of KOH/g)             | 0.56                  | 0.38   |

## 6. CONCLUSION

This paper shows that the emissions can be reduced by injecting the ethanol fuel with diesel at certain time intervals and using catalytic converter, diesel particulate filter. Injecting ethanol at different time intervals 2ms, 3ms, 4ms and 5ms are suitable for engine operations. Ethanol as to be prepared by starch-based crops by dry-wet-mill process. The use of EGR and various After Treatment devices (AFT) like Catalytic Convertors (CC), Diesel Particulate Filter (DPF) and DOC are required to reduce the emission further. And ethanol can also be used as a substitute for SI engines but needs greater modification in carbonation injection system. By using only ethanol and diesel fuels only NOx can be reduce, if the AFT devices are used HCs and CO can also be reduced.

## REFERENCES

- [1].The effect of using ethanol as additive on the combustion and emission of direct injection diesel engine. <https://doi.org/10.1016/j.renene.2016.09.044>.
- [2].Aditya Srinath, Antochan Sony Aerath and G Kasiraman, Experimental Investigation On The Usage Of Ethanol and DEE as Additives In a CI Engine, International Conference On Advances In Thermal Engineering and Application(2017).
- [3].Gurkamal Nain singh and Rabinder Singh Barj, Experimental Study Of Filtration Behavior Of Diesel Particulate Filter in a Diesel Engine to meet BS-VI Emission Norms in India,(2019).
- [4]. Chunde Yao ,C S Cheung. Effect of diesel/ethanol compound combustion on diesel engine combustion and emission. <https://www.researchgate.net/publication/239363375>.
- [5]. The effect of biodiesel and bioethanol blended diesel fuel on nanoparticles and exhaust emission from CRDI diesel engine. <https://www.researchgate.net/publication/228733340>

## EXPERIMENTAL STUDIES ON OSCILLATING HEAT PIPE USING NANO FLUIDS

Prerana A. M.<sup>1</sup>, Suhas H.J.<sup>1</sup>, Sachin Gharabude<sup>1</sup>, Keerthana M<sup>1</sup>, Parashuram A. K.<sup>2</sup>

<sup>1</sup>Students, <sup>2</sup>Assistant Professor

Department of Mechanical Engineering, K S Institute of Technology, Bangalore-560109, Karnataka, India

### ABSTRACT

*A heat pipe is a device that employs phase transition to transfer heat between two interfaces. Oscillating heat pipe (OHP) is the new and developing technique under thermal management domain of electronic devices. The main applications of oscillating heat pipes are to cool the electronic chips in the electronic devices, Spacecraft thermal control systems, and many more. The main objectives of this research is to carry out a detailed experimental studies on a Multi Turn Closed Loop Oscillating Heat Pipe, To study the heat transfer and fluid flow characteristics with pure working fluids and Nano fluids and to conduct the parametric studies with pure and nano fluid under varying heat input. In the present work, transient and steady state experiments are conducted on a multi turn closed oscillating heat pipes. In the present work, evaporator and condenser temperatures are measured and tracked with the help of a data logger. The parameters such as condenser and evaporator temperatures, the overall heat transfer coefficient and thermal resistance are assessed. The experimental results reveal that SWCNT particle-based Nano fluid is surpass the base fluid considered in terms of higher heat transfer coefficient and lower thermal resistance. The Multi Loop Oscillating Heat Pipe is found to operate on a higher standard for all heat loads & working fluids considered.*

**Keywords:** Oscillating heat pipe (OHP), Single Walled Carbon Nano Tube (SWCNT), Nanofluid, Thermal performance.

### 1. INTRODUCTION

Oscillating heat pipe (OHP) is the new and developing technique under thermal management domain of electronic devices. Numerous cooling methods are procured to cool the electronic devices. Oscillating Heat Pipe is being explored for electronic cooling devices with potential results. Although the conventional heat pipes are excellent heat transfer devices, their relevance is mainly restricted to transferring small amount of heat over moderately short distances.

Oscillating heat pipe (OHP) is a passive two-phase heat transfer device, which is a peculiar category of capillary tubes. It has been invented by Akachi [1-3], it exhibits self-sustained oscillation of the working fluid and phase change phenomenon leading to enhanced heat transfer. Due to its light weight, simple design, very fast response low fabrication cost at higher heat loads, OHPs have been contemplated as one of the compact heat transfer devices for innumerable cooling applications such as heat exchanger and space application, electronics cooling, etc. Since the last two decades, many investigators have examined its thermal performance theoretically and experimentally. These experimentations reveal that the Closed Loop Oscillating Heat Pipe (CLOHP) function is strongly affected by many factors including geometrical, operational and physical parameters.

Additionally, it is revealed that the problem of two-phase flow oscillation in closed loop Oscillating heat pipe is very complex because of many unbalanced variables and complications of thermo-hydrodynamic operational features. At the same time, some visual studies have been performed using glass tube to understand the operational characteristics and extensive progress has been also accomplished in these Attempts [4]. Recently, improving thermal characteristics of CLOHP has become a challenge and debating topic among researchers due to increasing heat load and diminution of electronic devices. Based on prevailing experimental results the working fluid is the most important factor in the CLOHP. Simultaneously, Nano fluids are regarded as advanced heat transfer fluids in heat transfer devices. The nanoparticles of size about less than 100nm are blended in the base fluid to form Nano fluid. The heat transfer characteristic of the base fluid is improved drastically due to increased surface area. In 1995, this perception was first proposed by Choi. Since. Then, some researchers concentrated on the heat transfer performance of Nano fluids such as, viscosity and thermal conductivity in flow with phase change and also, single-phase flow.

Presently, the nanofluid, considered as a working fluid in the electronic device, is an arising topic. In 2004, Tsai et al. [5] discovered application of nanofluids in the Conventional heat pipes employing gold nanoparticle solution and there was a considerable reduction observed in thermal resistance of heat pipe with nanofluid as compared to water. In 2006, Ma et al. [6] performed experiments under diverse operating temperatures and heat powers using water-based diamond nanofluid in the CLOHP.

They testified that the nanofluid could commendably improve heat transfer due to eventuality of strong oscillatory motion of flow. Lin et al. [7] noticed thermal enhancement of the heat pipe with by using water-based silver nanofluid at very low mass concentration.

Experiments are executed on two phase flows of the CLOHP using Nano fluid and DI water [8, 9]. Ji et al. [10] observed improvement in the start-up implementation of CLOHP due to alumina nanofluid. Jian Qu et al. [11] pointed out progress or decline of the CLOHP performance due to different nanoparticle deposition conduct with different nanofluids. A similar decline of heat pipe (thermosyphon) performance was found by Khandekar et al. [12]. It is perceived from pertaining literatures [5-12] that the improvement/decline of boiling performance in the heat pipes is because of change in surface property. The insignificant amount of the nanoparticle blended in the base fluid cannot essentially increase the thermal conductivity of the working fluid. Nonetheless,

the fluctuations of the particles in the working fluids might have supplementary contribution in enhancement of thermal performance of the CLOHP [6]. From the collected works [13–15], it is felt that the study of Nano fluids is still promising and won the whole, the understanding of two-phase flow heat transfer with the CLOHP is in the initial stage. Hence, experimental researches in both engineering and fundamental systems are needed.

Further, it is pointed that insufficient amount of work has been accomplished with use of metal nanoparticles in the CLOHP. Therefore, the current work aims at experimentally researching the thermal characteristics of the device using SWCNT Nano particle-based Nano fluids. Results of the current review are expected to help us to get familiar and design more proficient Nano fluid-charged CLOHP's functioning.

## 2. EXPERIMENTATION

### 2.1 Material Selection & Fabrication

The basic components that are used in OHP are copper tubes, borosilicate glass tubes, silicon rubber tubes for joining end to end of a glass and copper pipe and a thermocouple is used to measure the heat. Copper is used as the tube material since it is an excellent conductor of heat. The tube is bent into a multi loop U turn with a radius of 35mm. The glass tube is attached between the U turn copper tubes as we can clearly see the pulsation of the fluid inside the glass tube and it also acts as the adiabatic section. The tube is made of borosilicate glass, which can resist temperature up to 1200°C. Silicon rubber tubes are used as the connectors between glass and copper tubes. They can resist temperatures up to 400° C. Four 'K-type' thermocouples are used for temperature measurement. Two thermocouples are connected in the evaporator section and the other two at the condenser section at equal distances. A four-channel digital temperature indicator is used to record the temperatures at different locations. This is fed to the computer visuals using the TracerDaq software which displays the recorded temperature. A coil wound heater attached to evaporator section acts as the source of heat input, and the temperature can be varied with the help of a regulator. Water is used in condenser section to cool down the working fluid. The experimental setup is worked with two working fluids viz., water, and SWCNT based Nano fluids. The Working fluid is carefully measured for 60% fill ratio and is injected into the copper heat pipe using a syringe. Then the heat input of 25W,30W,35W,40W is given and to avoid heat loss at the evaporator section glass wool is kept as a heat insulation material and the experiment is kept under observation for 30min and the corresponding values are recorded.

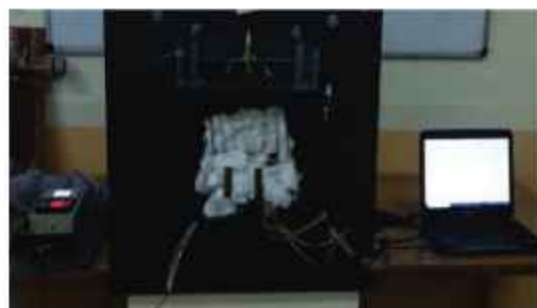

FIGURE 1. OHP experimental setup

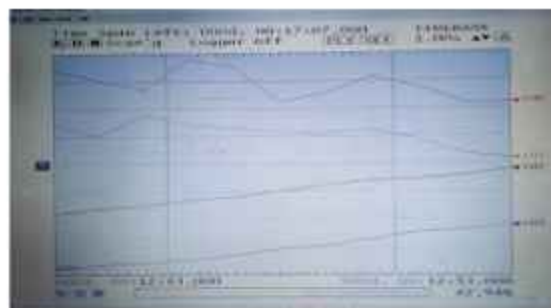

FIGURE 2. Values obtained from datalogger

### 2.2 Experimental Procedure

Before conducting the experiment, it is ensured that there is no fluid inside the tubes. The required amount of measured working fluid is then injected into the copper tube through a syringe by opening one end of the valve such that the fluid enters the evaporator section. Then the valve is closed using the silicon tube and hence it forms a closed loop. Then the display unit is switched ON and the required wattage(25W,30W,35W,40W) is set. The transient experiments are conducted and the various temperatures are recorded through a datalogger. The output of the temperature data logger with the help of the software is monitored in the computer. The experiments are performed for a duration of 30min each.

The colloidal solution of SWCNT particle Nano fluids is prepared by using water as base fluid and experimentation is carried out by varying the heat input as well as by varying the fill ratio. The values obtained will be plotted by a graph of thermal resistance with heat input and heat transfer coefficient with heat input. A typical output from the data acquisition system is as shown below.



### 3. RESULTS AND DISCUSSION

Transient experiments have been conducted with the working fluids i.e., water and SWCNT based Nano fluid and variations of temperature with time are recorded. The experiments are conducted for a duration of 30min.

Fig 3 shows the variation of temperature difference between evaporator and condenser with time at heat inputs for 25W, 30W, 35W and 40W respectively for water at a fill ratio of 60%. It is observed that the temperature difference between evaporator and condenser is considerably less at lower heat input of 25 W and it increases for increase in wattage. For more accurate results we have conducted two trials for every wattage of each fluid.



FIGURE 3. Temperature Difference (TE-TC) Plot for water

Fig 4 shows the variation of temperature difference between evaporator and condenser with time at different heat inputs for SWCNT at a fill ratio of 60%. It is observed that the temperature difference between evaporator and condenser is considerably less at lower heat input of 25 W and gradually increase with increase in heat input.

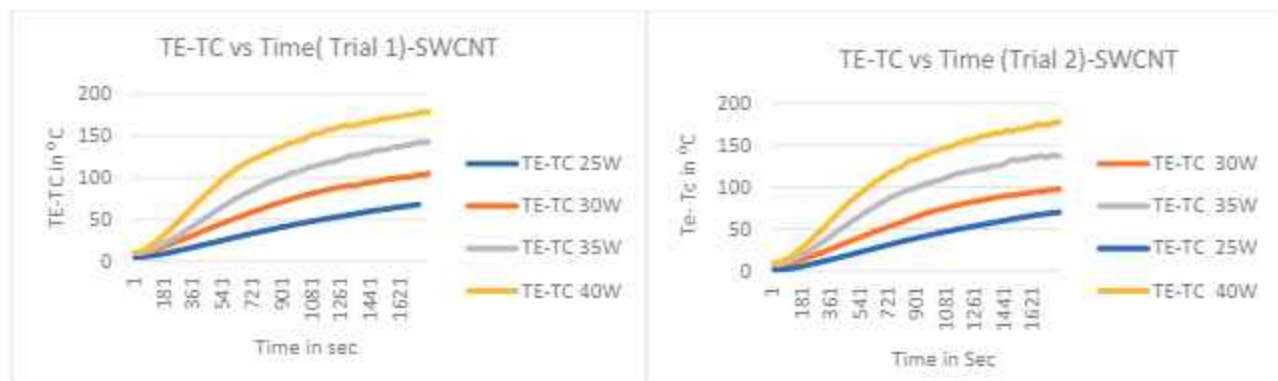

FIGURE 4. Temperature Difference (TE-TC) Plot for SWCNT

Finally, the effectiveness of the heat pipe is indirectly brought in terms of thermal resistance and convective heat transfer coefficient.

#### CALCULATIONS

The capillary tube material used in the evaporator and condenser sections are copper material. The specifications of the capillary tube are inner diameter of 1.5 mm and outer diameter of 3 mm. The total length of the closed loop oscillating heat pipe is 2040mm. The experiments are conducted in vertical position for different heat input in steps of 5W from 25W to 40W.

Length of the Heat Pipe = 206 cm

Diameter = 2 mm

$$Vf = \frac{\pi}{4} * d^2 * L$$

$$Vf = \frac{\pi}{4} * [0.002]^2 * 2.06$$

$$Vf = 6.4 * 10^{-5} \text{ m}^3$$

$$Vf = 64 * 10^6$$

$$Vf = 64 \text{ cc}$$

$$As = \pi DL$$

$$= \pi * 0.002 * 2.06$$

$$As = 0.0129 \text{ m}^2$$

The thermal resistance is computed as,

$$R_{th} = \frac{T_E - T_C}{Q} \text{ [}^\circ\text{C / W]} \text{ -----(1)}$$

Convective heat transfer co-efficient is given by

$$h = \frac{Q}{As * (T_E - T_C)} \text{ [W / }^\circ\text{C m}^2\text{]} \text{ -----(2)}$$

Where,

TE = Evaporator temperature in  $^\circ\text{C}$

TC = Condenser temperature in  $^\circ\text{C}$

Q = Heat input in W

As = Surface area of the condenser section of heat pipe in  $\text{m}^2$

Rth = Thermal resistance in  $^\circ\text{C / W}$

h = Heat transfer coefficient in  $\text{W / }^\circ\text{C m}^2$

Fig.7 &8 shows the variation of thermal resistance and heat Transfer coefficient with heat load at steady state for Water and SWCNT at a fill ratio of 60%. It is observed that the thermal resistance decreases with increase in heat input & heat Transfer coefficient increases with increase in heat load for both Water and SWCNT.



FIGURE 7. Thermal Resistance vs heat input

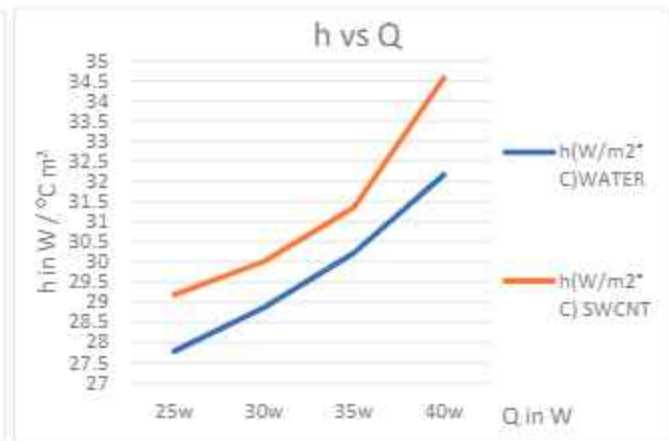

FIGURE 8. Heat transfer coefficient vs heat input

| Q (W) | R <sub>th</sub> (°C/W)<br>WATER | h(W/m <sup>2</sup> °C)<br>WATER |
|-------|---------------------------------|---------------------------------|
| 25W   | 2.79                            | 27.78                           |
| 30W   | 2.685                           | 28.864                          |
| 35W   | 2.565                           | 30.22                           |
| 40W   | 2.4097                          | 32.169                          |

TABLE 1: Experimental values of Water

TABLE 2: Experimental values of SWCNT

| Q (W) | R <sub>th</sub> (°C/W)<br>SWCNT | h(W/m <sup>2</sup> °C)<br>SWCNT |
|-------|---------------------------------|---------------------------------|
| 25W   | 2.6554                          | 29.191                          |
| 30W   | 2.5825                          | 30.01                           |
| 35W   | 2.472                           | 31.35                           |
| 40W   | 2.242                           | 34.57                           |

#### 4. CONCLUSION

In the current investigation, the experimental research is executed on a Multi Turn Loop OHP. The effects of working fluid, heat input and fill ratio on the performance of OHP are analyzed.

Following conclusions are made from the experimentation:

- The change of temperature between condenser and evaporator with time is found to be recurring.
- The difference in temperature between evaporator and condenser at constant state is found to be less for SWCNT in comparison to water.
- SWCNT is observed to be more suitable working fluid for OHP operation under varying operating conditions.
- The results show that SWCNT has more heat transferring capacity with less temperature difference and less thermal resistance. Thus, SWCNT can be considered as more suitable working fluid for OHP functioning.

#### REFERENCES

- [1]. Akachi, Structure of a heat pipe, US Patent # 4991041, 1990.

- [2] H. Akachi, Structure of micro-heat pipe, US Patent # 5219020, 1993. [3] H. Akachi, F. Polasek, P.S. Tulc, Pulsating heat pipes, in: Proceedings of the Fifth International Heat Pipe Symposium, Melbourne, Australia, (1996) 208–217.
- [4] S. Khandekar, P. Charoensawan, M. Groll, P. Terdtoon, Closed loop pulsating heat pipes -Part B: visualization and semi-empirical modelling, *Appl. Therm. Eng.* 23 (2003) 2021–2033.
- [5] C.Y. Tsai, H.T. Chien, P.P. Ding, B. Chan, T.Y. Luh, P.H. Chen, Effect of structural character of gold nanoparticles in nanofluid on heat pipe thermal performance, *Mater. Lett.* 58 (2004) 1461–1465.
- [6] H.B. Ma, C. Wilson, Q. Yu, K. Park, S.U.S. Choi, Murli Tirumala, An experimental investigation of heat transport capability in a nanofluid oscillating heat pipe, *J Heat Transfer* 128 (2006) 1213–1216.
- [7] Y.-H. Lin, S.W. Kang, H.L. Chen, Effect of silver nano-fluid on pulsating heat pipe thermal performance, *Appl. Therm. Eng.* 28 (2008) 1312–1317.
- [8] N. Bhuwaketkumjohn, S. Rittidech, Internal flow patterns on heat transfer characteristics of a closed-loop oscillating heat-pipe with check valves using ethanol and a silver nano-ethanol mixture, *Exp. Therm. Fluid Sci.* 34 (8) (2010) 1000–1007.
- [9] Q.-M. Li, Jiang Zou, Zhen Yang, Yuan-Yuan Duan, Bu-Xuan Wang, Visualization of two-phase flows in nanofluid oscillating heat pipes, *J. Heat Transfer* 133(2011). 052901-1.
- [10] Y. Ji, H.B. Ma, Fengmin Su, Guoyou Wang, Particle size effect on heat transfer performance in an oscillating heat pipe, *Exp. Therm. Fluid Sci.* 35 (2011) 724–727.
- [11] J. Qu, Huiying Wu, Thermal performance comparison of oscillating heat pipes with SiO<sub>2</sub>/water and Al<sub>2</sub>O<sub>3</sub>/water nanofluids, *Int. J. Therm. Sci.* 50 (2011) 1954–1962.
- [12] S. Khandekar, Yogesh M. Joshi, Balkrishna Mehta, Thermal performance of closed two-phase thermosyphon using nanofluids, *Int. J. Therm. Sci.* 47 (2008) 659–667.
- [13] Lixin. Cheng, Lei. Liu, Boiling and two phase flow phenomena of refrigerant based nanofluids: fundamentals, applications and challenges, *Int. J.Refrigeration* 36 (2013) 421–446.

## DESIGN AND FABRICATION OF MIST IRRIGATION SYSTEM

<sup>1</sup> Sumanth Kumar R, <sup>2</sup>Kunal Sagar S, <sup>3</sup>Nikhil Singh K, <sup>4</sup>Prajwal S, <sup>5</sup> Dr. Nirmala L

<sup>1234</sup> UG-students

<sup>5</sup>Associate Professor

Department of Mechanical Engineering,  
K.S. Institute of Technology Bangalore -560109

### ABSTRACT

*Irrigation or water use for agriculture is the biggest water consumer. Reducing water use for irrigation means significantly to water saving. Drip and mist irrigations are methods of water application which consume water more efficiently and more agriculture products produce from same amount of water. This project aimed to assess performance of mist irrigation to supply irrigation water for sapling. The vegetables cultivated were spinach, mustard, and water spinach. The indicators employed were discharge, uniformity, and water productivity. The uniformity was measured using distribution uniformity (DU) and Christiansen uniformity index (CU).*

**Keywords:** Irrigation, Water, Temperature, Agriculture, Mist irrigation, nozzle.

### 1. INTRODUCTION

Irrigation is a very essential part of agriculture especially when there is inadequate supply of water through rain fall. Therefore, there should be an easy way to irrigate the plants [1]. In many areas of the planet, the quantity of rainfall isn't capable to meet the moisture requirements of crops. Hence Mist irrigation is an important improvement over convenient to other irrigations. It stimulates natural rainfall by breaking water droplets within the sort of rain uniformly over the land surface when needed at required quantity during a uniform pattern, this type of irrigation not only helps in propagation of right amount of water to the plant but also to control the temperature around it, this system is specific for a crop and hence its usage is limited [2].

Though there are various processes available for developing FGMs, an cost effective method for production of the bulk FGMs, liquid metallurgy route with centrifugal force method is preferred for the reason that, it is economically feasible and capable to produce large size products. Centrifugal casting is found to be the simplest and cost effective technique for producing large size engineering components, such as pipes, shafts, bushings. This project aims to fabricate horizontal centrifugal casting machine and also develop Al6061 alloy using fabricated machine.

Proper scheduling of irrigation is critical for efficient water management in crop production, particularly under conditions of water scarcity. The effects of the applied amount of irrigation water, irrigation frequency and water use are particularly important. To improve water efficiency there must be a proper irrigation scheduling strategy. So this project devices design and fabrication of mist irrigation system. This process could thus eliminate the excess piping required in case of the drip irrigation and sprinkler irrigation systems [3]. The mist irrigation system is very efficient and saves both manual labour and water consumption.



FIGURE 1. Mist from Nozzle



FIGURE 2. Lay out for testing mist irrigation

Nozzles were rated at 1/8 inch of water per hour at 40 pounds pressure. Later in the season it was obvious that the nozzles were spaced too closely; therefore every other nozzle was removed for the remainder of the season except in the west and east border rows. Four nozzles were also left at the south end of each lateral.

Nozzle: A durable, fail-safe nozzle is an indispensable part of an effective mist system. You don't want nozzles leaking...

Compression fittings: Compression fittings are sturdier pieces that connect your water-brining hose to water-misting...

Tube or hose: The water-carrying tube is the most easy-to-use and economical part of the mister system. Choose a 1/4-inch...

Filter: attaching a mesh filter to the spigot that feeds your mister system is mandatory.

## 2. MATERIALS AND METHODOLOGY

Cauliflower seeds of the variety "lettuce seeds" were seeded on may17 2022, after 10 days the seedlings were transplanted to wooden flats 2.5 by 2.5 inches apart. On may30th the plants were planted in the field and watered immediately after transplanting. Rows were spaced feet a apart and the plants within the rows. A mist system was installed over the plots so that mist could cover the entire area.

The main water line on the north side of the plots ran in an east-west direction, Mist lines were place over the rows. Running south from the main line. This line was 3 feet long and 0.8cm in diameter. The three lateral lines containing the mist nozzles were 0.3cm in diameter and 9 feet long. The lateral lines on the west side of the plot were placed feet apart. The next lines were placed the two lines on the east side of the plot were placed feet apart.

The analysis consisted of parameters, namely discharge, distribution uniformity, Christiansen uniformity index, vegetable water productivity, and biomass water productivity. Discharge received of each box were calculated using equation

$$Q=V/t$$

Where Q was discharge, V was volume of irrigation water collected on each box, and t was duration of each operation



FIGURE 3. Germination of seeds in the selected area

### 3. RESULTS AND DISCUSSION

This project tried to assess the performance of water saving irrigation. The water saving meant the irrigated farming produce more harvest from a unit of water consumption, this projects also aims to control the temperature around the plants so that the plant is at optimum condition no matter the natural temperature outside. the table 1 shows the water discharge compare with drip irrigation and mist irrigation .

TABLE 1. Water discharge compare with drip irrigation and mist irrigation

| Type            | Minimum discharge, $q_{min}$ | Maximum discharge, $q_{max}$ |
|-----------------|------------------------------|------------------------------|
| Drip irrigation | 4.25 ml/sec                  | 8.25 ml/sec                  |
| Mist irrigation | 0.81 ml/sec                  | 1.78 ml/sec                  |

TABLE 1: Water productivity ( $kg/m^3$ )

| Type            | indicator                    | spinach         | lettuce         |
|-----------------|------------------------------|-----------------|-----------------|
| Mist irrigation | Vegetable water productivity | 0.8360 $kg/m^3$ | 0.8250 $kg/m^3$ |

### 4. CONCLUSION

This project provides a significant increase in the advantages to traditional irrigation methods. It provides the moisture to the plant as well as to the atmosphere surrounding the plant there by maximizing the water usage. It uses various calculation and equipment to reduce water consumption and excess pipeline. Thus this is the complete improvement to the traditional agricultural irrigation methods and also to most of the automated methods such as manual irrigation, drip irrigation, spray irrigation system etc

#### Future Scope

The future scope of this project can be made compatible with automated smart irrigation system is designed so that the user has full control and almost no manual work. it can be made into large scale agricultural fields, it also helps in controlling crop control during droughts and other drastic climate changes. It can also help in yielding good quality seasonal or non-seasonal crops/plants for modern agriculture, a smart irrigation system is one of the best techniques that give more production in minimum duration. To many extend, this smart irrigation system is designed and fully automated to minimize manual handling in agriculture.

## ACKNOWLEDGEMENTS

We would like to extend our sincere thanks to all those who played a role in the completion of this project. Firstly, we are highly indebted to "K S Institute of Technology" Bangalore for their constant supervision and support. we are immensely grateful to all those involved in this project as without their inspiration and valuable suggestion it would not have been possible to develop the project within the prescribed time period.

## REFERENCES

- [1] Design and Implementation Of Automatic Plant Irrigation System Dr.P.Sengottuvel, Dr.J.Hameed Hussain, Professor, Department of Mechatronics, Department of Mechanical BIST, BIHER, Bharath University, International Journal of Pure and Applied Mathematics Volume 118 No. 18 2018.
- [2] Agricultural Sprinkler for Irrigation System, Nirali Hemant Patel Student, Chintan Rajnikant Prajapati Student, Mechatronics G.H. Patel College of Engineering and Technology, International Journal of Engineering Research & Technology (IJERT) <http://www.ijert.org> ISSN: 2278-0181 Vol. 9 Issue 05, May-2020.
- [3] Smart Irrigation System S. Darshna, T.Sangavi, Sheena Mohan, A.Soundharya, Sukanya Desikan IOSR Journal of Electronics and Communication Engineering (IOSR-JECE) Volume 10, Issue 3, Ver. II (May - Jun.2015), PP 32-36.
- [4] Constantinos Marios Angelopoulos, Sotiris Nikolettseas, Georgios Constantinos Theofanopoulos, A Smart System for Garden Watering using Wireless Sensor Networks, MobiWac, October 31–November 4, 2011.
- [5] R.suresh, S.Gopinath, K.Govindaraju, T.Devika, N.Suthanthira Vanitha, GSM based Automated Irrigation Control using Raingun Irrigation System, International Journal of Advanced Research in Computer and Communication Engineering , Vol. 3, Issue 2, February 2014.
- [6] Rafael Muñoz-Carpena and Michael D. Dukes, Automatic Irrigation Based on Soil Moisture for Vegetable Crops, IFAS Extension, 2005.
- [7] K.N.Manjula B.Swathi and D.Sree Sandhya , Intelligent Automatic Plant Irrigation System.
- [8] G. Vellidis, M. Tucker, C. Perry, C. Kvien, C. Bednarz, "A Real-Time Wireless Smart Sensor Array for Scheduling Irrigation", National Environmentally Sound Production Agriculture Laboratory (NESPAL), 2007.
- [9] Anitha K, "AUTOMATIC IRRIGATION SYSTEM" 2nd International Conference on Innovative trend in Science, Engineering and Management, ISBN: 978-93-86171-10-8, 2016.



## EFFECT OF COMBINATION OF METHANOL INJECTION AND AFTER TREATMENT DEVICES ON DIESEL ENGINE EMISSION- A REVIEW

Santhosh M<sup>1</sup>, Omkar M V<sup>1</sup>, Sai karthik<sup>1</sup>, Bhaskar R<sup>1</sup>, Nagaprasad K S<sup>2</sup>

<sup>1</sup> Students, <sup>2</sup> Associate Prof  
Department of Mechanical Engineering  
K.S. Institute of Technology Bangalore -560109

### ABSTRACT

*In Diesel/methanol compound combustion system (DMCC) the effect of methanol injection timings on combustion, performance and emissions were comprehensively investigated. The experimental results demonstrated that methanol injection timings plays important roles in combustion and emission control. Nox and soot emission were all decreased while HC and CO emission increased significantly. HC emission firstly increased and then decreased, while CO emission always increased.*

### 1. INTRODUCTION

Diesel engine is an internal burning engine where in start of the fuel is brought about by the raised temperature of the air in the chamber because of the mechanical pressure. Diesel engines works by packing just the air. This builds the air temperature inside the chamber to such a serious level that atomized diesel fuel infused into the burning chamber lights suddenly. In any case, the issue with diesel engine is its higher pace of contamination discharges. Among the fundamental contaminations Nitrogen Oxides (NOx), Carbon Monoxide (CO), Hydrocarbons (HC), Particulate Matter (PM), Carbon Dioxide (CO<sub>2</sub>), Sulphur Dioxide (SO<sub>2</sub>), aldehydes most unsafe poisons of diesel engine are NOx and PM. To adapt to the exacting discharge standard, green engine which diminishes exhaust emanation ought to be created. Execution of after-treatment frameworks like Diesel particulate channel (DPF), incite critical increase in outflows decrease were attempted. Diesel particulate channels (DPF) is the gadgets that truly catch diesel particulate matter in the Fumes line to Forestall the Delivery to the Climate.[1]

#### 1.1 Diesel Engine

A 4-stroke engine is a very common variation of an internal combustion engine. Most modern internal combustion-powered vehicles are 4-strokes, powered by either gasoline or diesel fuel. During engine operation, pistons go through 4 events to achieve each power cycle. The definition of an event is an up or down piston motion. Upon completion of the 4 events, the cycle is complete and ready to begin again. 4-stroke engines deliver a good balance of power, reliability and efficiency. When it comes to emissions, 4-strokes separate each event mechanically, which reduces unburned fuel emissions. It also separates oil from fuel, which significantly reduces carbon monoxide emissions. This combination of desirable traits has earned the 4-stroke the top spot in passenger vehicles today.[2]



FIGURE 1: CRDI Diesel Engine

#### 1.2 Diesel Particulate Filter

The particulate filter consists of a porous ceramic (silicon carbide). it has a honeycomb like structure with a large number of channels that are alternately closed at their ends so that the exhaust gas flow is forced to pass through the fine pores of the filter walls. The gaseous substances can pass through without any problem, where by the much larger soot particles and other solids are retained on the partition walls and deposit on the wall surfaces. [3].



FIGURE 2: Diesel Particulate Filter

### 1.3 Catalytic Converter

As emission regulations have tightened, the complexity of the catalytic converter system has increased. Meeting the demands of tightening legislation may require increased converter volume, translating into the use of multiple catalytic converter elements within a vehicle exhaust system.

Components used in this work consisted of Cordierite flow-through monoliths wash coated with alumina and platinum catalyst as well as Pt/Pd which provides low temperature T50 values for CO and HC. But in the case of under floor catalytic converter, which is widely used for many years because of convince of packaging as its catalyst LOT has 200 to 300s. In order to reduce this delay, and to increase the efficiency of the catalyst at low temperature, the improvement in wash coat formulation is introduced with the help of new precious metals such as Pt/Pd

Oxidation of carbon monoxide to carbon dioxide:

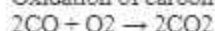

Oxidation of hydrocarbons (unburned and partially burned

Fuel) to carbon dioxide and water:

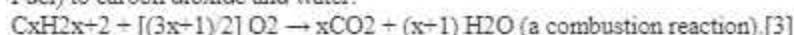

## 2. TEST PREPARATION

The setup consists of single cylinder, four stroke, Diesel engine connected to eddy current dynamometer for loading. It is provided with necessary instruments for combustion pressure and crank-angle measurements. These signals are interfaced to computer through engine indicator for PV diagrams. Provision is also made for interfacing airflow, fuel flow, temperatures and load measurement. The set up has stand-alone panel box consisting of air box, fuel tank, manometer, fuel measuring unit, transmitters for air and fuel flow measurements, process indicator and engine indicator. Rota meters are provided for cooling water and calorimeter water flow measurement.

When the engine is started the diesel is supplied to the combustion chamber directly and the ethanol is supplied to the engine by Time Valve at different time intervals like 2millisec, 3millisec, 4 millisec, 5 millisecond using manifold injection with help of ECU. The emission of the engine is tested for different loads at different time intervals.

TABLE 1: Properties of Methanol and Diesel

| Properties                   | METHANOL                                      | Diesel |
|------------------------------|---|--------|
| Density (kg/m <sup>3</sup> ) | 792   | 816    |
| Kinematic viscosity          | 0.792-7.37*10 <sup>-7</sup> m <sup>2</sup> /s | 2.20   |
| Flash point                  | 9   | 48     |
| Fire point                   | 36  | 55     |
| Calorific value (MJ/kg)      | 22.7  | 45.66  |
| Pour point                   | -12   | -9     |
| Total acidity (mg of KOH/g)  | 0.56  | 0.38   |

## 3. CONCLUSION

This paper shows that the emissions can be reduced by injecting the methanol fuel with diesel at certain time intervals and using catalytic converter, diesel particulate filter. Injecting methanol at different time intervals 2ms,3ms,4ms and 5ms are suitable for engine operations.

The use of various ATD devices like CC,DPF and DOC are required to reduce the emission further. and methanol can also be used as a substitute for SI engines but needs greater modification in injection system.

## REFERENCES

- [1] Dava , A.W. Ibrahim and O.Zhang, Naval Undersea Warfare Centre, Newport, RI, 'Control of diesel engine emissions by dilute oxidizer injection', Energy conversion engineering conference, 1996, IECEC96, Vol.3.
- [2] Dimitrios Theofanis Hountalas, George C. Mavropoulos, Theodoros Zannis, Sotirios Mamalis, 'Use of Water Emulsion and Intake Water Injection as NOx Reduction Techniques for Heavy Duty Diesel Engines', National Technical Univ. of Athens, SAE 2006-01-1414.
- [3] V. Sajith, C. B. Sobhan and G. P. Peterson, 'Experimental Investigations on the Effects of Cerium Oxide', Hindawi Publishing Corporation Advances in Mechanical Engineering, Nanoparticle Fuel Additives on Biodiesel, Volume 2010, Article ID 581407
- [4]Ho Teng, James C. McCandless and Jeffrey B.Schneyer, 'Thermochemical Characteristics of Dimethyl Ether- An Alternative fuel for compression-ignition engines', SAE 2001-01-0154.
- [5]Nagaprasad K.S., Prabhakara S.S., Shivakumar S., Dr. D. Madhu, "Water Injection in an Internal Combustion Engine- A Review", Proc. of National Conference on Recent Trends in Mechanical Engineering Sciences, RTIMES-08, SSIT, Tumkur,21-22 Feb 2008, page 12.

## DESIGN AND FABRICATION OF LOW COST MECHANICAL VENTILATOR

Anirudh R<sup>1</sup>, Harsha P<sup>1</sup>, Mallikarjun Holde<sup>1</sup>, Mohan R Krishna<sup>1</sup>, Nirmala L<sup>2</sup>

<sup>1</sup> Students, <sup>2</sup> Associate Professor  
Department of Mechanical Engineering  
K.S. Institute of Technology Bangalore -560109

### ABSTRACT

This paper shows the construction of low cost mechanical ventilator, which is a device used for patients with acute breathing problems. The main motivation for this project is to bridge the demand for ventilator during covid19 and to reduce the cost of ventilation. This is very effective and matches with the clinical ventilators. Simple mechanism (slider and crank) is selected wisely to get effective ventilation at min cost. Experiments carried out in the laboratory that had emulated healthy and unhealthy patients illustrate the potential benefits of the derived mechanical ventilator.

**Keywords:** Mechanical ventilator, low-cost ventilator, Covid-19, Slider crank.

### 1. INTRODUCTION

Ventilators are the life saving machines used as very crucial equipment in ICU's it is used for the patients with acute respiratory failure [1]. The concept of ventilation is not new it was developed by Greek physician and scientist Galen in second century AD [2]. At that time it was termed as "iron lungs" [4]. Later on during mid of 16th century scientist by name Andreas Vesalius published his work by the title

"Dehumani corporis fabrica" which is the base for modern positive pressure ventilator [5]. In 1864 Alfred Jones designed first ventilator which at the time was used to treat paralysis, bronchitis, asthma [6]. Later on lot of development took place in this field as a result we have more sophisticated more accurate ventilators in hospitals [7]. But situation changed after February 2020 the need of ventilator increased to peak due to the pandemic Covid-19. India having a population of 140 crore has only 48000 clinical ventilators [8], number of cases crossed 7 lacks per day this created huge shortage of clinical ventilator, it was imported from different countries in large amount [9]. At that time the concept of low cost portable ventilator was introduced this can be used to a patient [12] with mild to moderate respiratory failures it is non invasive [13], reliable device that can be used as alternative to bulky expensive hospital ventilators this ventilators can be brought by small clinics or an individual and it does not require any specialized person to operate it [14].

### 2. MATERIALS

#### 2.1. Ply Wood:

Plywood is a material manufactured from thin layers or "plies" of wood veneer that are glued together with adjacent layers. It is an engineered wood from the family of manufactured boards which include medium-density fiberboard (MDF), oriented strand board (OSB) and particle board (chipboard). The board is used of dimension 550\*305mm as shown in fig1



FIGURE 1. Plywood

## 2.2 PVC PIPE:

PVC pipes have clear environmental advantages over traditional materials. As PVC is a low carbon plastic, PVC pipes require less energy and fewer resources to manufacture. Moreover the ultra-smooth surface of PVC pipes reduces pumping costs and energy use. The pipes are of 290mm length, 32mm diameter and 405mm length, 26mm diameter, shown in fig2



FIGURE 2. PVC Pipes

## 2.3 FLANGE:

A flange is a method of connecting pipes, valves, pumps and other equipment to form a piping system. Pipe flanges are manufactured in all the different materials like stainless steel, cast iron, aluminum, brass, bronze, plastic etc. The flange we used is of 8mm diameter. As Shown in fig3



FIGURE 3. Flange

## 2.4 AMBUBAG:

A bag valve mask (BVM), sometimes referred to as an Ambu bag as shown in fig 4, is a handheld tool that is used to deliver positive pressure ventilation to any subject with insufficient or ineffective breaths. It consists of a self-inflating bag, one-way valve, mask, and an oxygen reservoir. A Ambu bag of 1600ml capacity is used.



FIGURE4.. Ambubag

## 2.5 DC MOTOR:

Motors are the electro mechanical devices that convert electrical energy in to mechanical energy in the form of torque and rotation. Either alternating current or direct current can be used as an input to the motor. The result is the mechanical motion either translation or rotation. It has mainly two parts namely stator and rotor. Stator is the stationary electrical

component and rotor rotates with the main shaft. We have used a motor of 12V,3A and 20kg-cm torque.

## 2.6 SPEED CONTROLLER:

Motor speed controllers are electronic devices that control motor speed. They take a signal for the needed speed and drive a motor to that speed. The controller is of 12v, 3A operating power . As Shown in fig 6



FIGURE 6. .Speed controlling unit

## 2.7. POWER SUPPLY:

A power supply is an electronic circuit that converts the voltage of an alternating current (AC) into a direct current (DC) voltage. It is basically consisting of the following elements: transformer, rectifier and filter. It converts Ac to DC and supplies current at 12v.

## 3. METHODS

The layout as shown in fig 8 was constructed in order to reduce the area and arrange the components compactly and efficiently for working purpose.

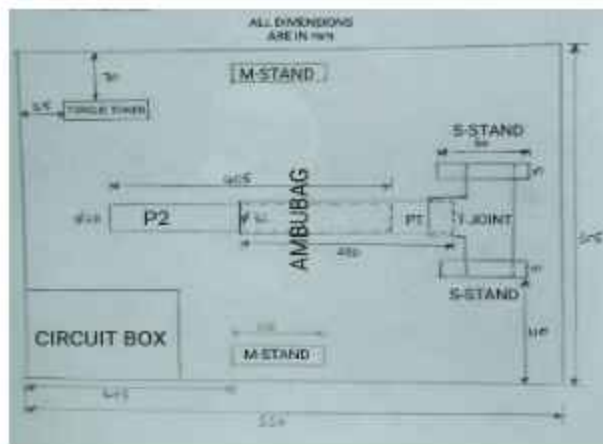

FIGURE 8. 2D Layout

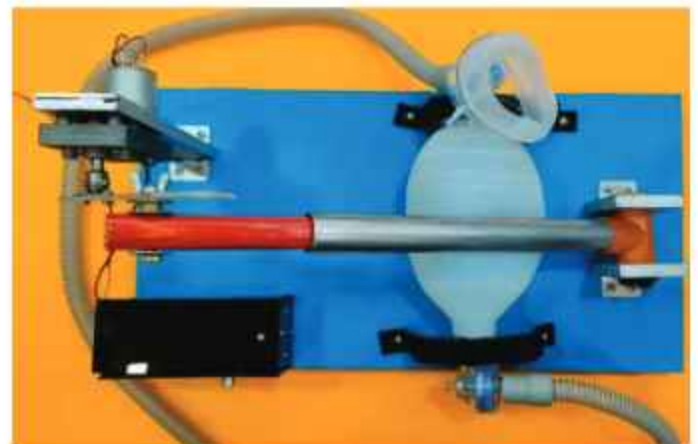

FIGURE 9.. Fabricated Model

Two S-stands are mounted on the ply wood base to support the slider crank mechanism using T joint, Ambu bag is placed over the M-stand above which PVC pipes are incline arranged. On the left top of layout torque tower is placed where DC motor rotates the acrylic arm in clockwise direction, whose speed can be altered from the circuit box, where circuit connections are done. The final outlook is as shown in fig(9) .

## 4. WORKING PRINCIPLE

Fabrication was made in such a way that during the first half cycle rotation of the acrylic arm the PVC link compress the ambu bag that creates the pressure on the outer valve due to which the oxygen is pushed towards the patient. Similarly during the second half cycle of acrylic arm the PVC link retraces its path, due to the vacuum created in the bag the pressure is built on the inlet valve as the result oxygen occupies the void space in the ambu bag. This is how the slider crank mechanism of the PVC link helps in pumping the oxygen.

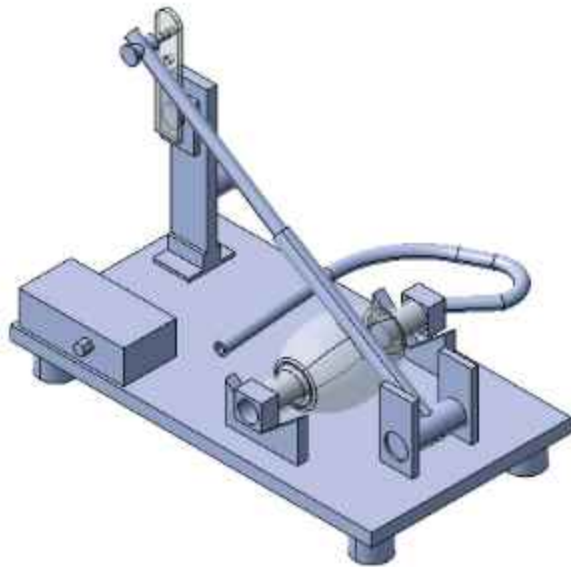

FIGURE 10. 3D Catia Model



FIGURE 11. Fabricated Model

## 5. RESULTS AND DISCUSSION

Fabricated device was tested at its full operating speed which is about 13-15 rpm which is the average rate of breathing [1], and at different settings of compression of the ambubag and the results found are as shown in the table.

TABLE 1. Experimental results

| SI No | COMPRESSION | PRESSURE<br>(mm of Hg) | PRESSURE<br>(Kpa) |
|-------|-------------|------------------------|-------------------|
| 1     | 1/4         | 7                      | 0.93              |
| 2     | 1/2         | 13                     | 1.73              |
| 3     | 3/4         | 18                     | 2.4               |

The average pressure which is needed for an adult is 5-25mm of Hg[8]. After the conduction of the experiment the pressure developed during the 1/4<sup>th</sup> compression was 7mm of Hg (0.93Kpa), at 1/2 compression the pressure developed was 13mm of Hg (1.73Kpa), at 3/4<sup>th</sup> compression the pressure developed is 18mm of Hg (2.1Kpa). The developed pressure falls well within the range of pressure that is required for an adult.

## 6. CONCLUSION

The developed project works on the principle of slider crank mechanism to develop positive pressure for respiration, and the pressure developed falls under the required range of pressure required for an adult human, the device built is cost effective and can be used on patients with low to moderate respiratory problems.

## 7. REFERENCES

- [1] D. J. Dries and J. J. Marini, "Mechanical Ventilation," *Crit. Care Nephrol.* Third Ed. vol.196, no. April, pp. 10-21.e2, 2019, doi:10.1016/B978-0-323-44942-7.00003-0.
- [2] G. C. Khilnani and V. Hadda, "Basic mechanical ventilation," *ICU Protocol. A Step wise Approach Vol I*, pp. 45–53, 2019, doi:10.1007/978-981-15-0898-1\_5.
- [3] P. Rodriguez, M. Dojat, and L. Brochard, "Mechanical ventilation: Changing concepts,"  
a. *Indian J. Crit. Care Med.*, vol. 9, no. 4, pp. 235–243, 2005, doi:10.4103/09725229.19765.
- [4] L. Acho, A.N. Vargas, and G. Pujol-Vázquez, "Low-Cost, open-source mechanical  
a. ventilator with pulmonary monitoring for COVID-19 patients," *Actuators*, vol. 9,  
b. pp. 1–14, 2020, doi:10.3390/act9030084
- [5] J. Zuckerberg, M. Shaik, K. Widmeier, T. Kilbaugh, and T. D. Nelin, "A lung for all: Novel mechanical ventilator for emergency and low-resource settings," *Life Sci.*, vol. 257, no. June, p. 118113, 2020, doi:10.1016/j.lfs.2020.118113.
- [6] A. Mohsen Al Hussein, H. Ju Lee, J. Negrete, S. Powelson, A. Tepper Servi, and A. H. Slocum, "Design and prototyping of a low-cost portable mechanical ventilator," *J. Med. Devices, Trans. ASME*, vol. 4, no. 2, pp. 1–1, 2010, doi:10.1115/1.3442790.
- [7] V. Kumar, R. Kumar, M. Kumar, G. S. Wander, V. Gupta, and A. Sahani, "Recent advances in low-cost portable automated resuscitator systems to fight COVID-19," *Health Technol. (Berl.)*, vol. 12, no. 1, pp. 181–191, 2022, doi:10.1007/s12553-021-00629-4
- [8] A. Mohsen Al Hussein, H. Ju Lee, J. Negrete, S. Powelson, A. Tepper Servi, and A. H. Slocum, "Design and prototyping of a low-cost portable mechanical ventilator," *J. Med. Devices, Trans. ASME*, vol. 4, no. 2, pp. 1–1, 2010, doi:10.1115/1.3442790.
- [9] L. E. Schwab, "Basics of mechanical ventilation," *Trauma*, vol. 45, no. 4, pp. 61–70, 2003, doi: 10.5005/jp/books/13067\_13.
- [10] et al. Vivas Fernández, Francisco José, "ResUHUrge : A Low Cost and Fully Functional," *Sensors*, vol. 20, no. 23, 2020, [Online]. Available: <https://www.mdpi.com/1424-8220/20/23/6774/html>
- [11] S. Fludger and A. Klein, "Portable ventilators," *Contin. Educ. Anaesthesia, Crit. Care Pain*, vol. 8, no. 6, pp. 199–203, 2008, doi: 10.1093/bjaceaccp/mkn039.
- [12] W. H. Organization, "Technical specifications for invasive and non-invasive ventilators for COVID-19," *Interim Guid.*, no. April, pp. 1–10, 2020.
- [13] T. Laerdal, "Portable ventilators," *Br. J. Anaesth.*, vol. 54, no. 8, p. 900, 1982, doi: 10.1093/bja/54.8.900-a.
- [14] J. Brewer, "Senior Project Final Report Portable Ventilator Table of Contents ;," 2021.
- [15] C. Care, N. Knowledge, O. F. Evidence, and V. A. Pneumonia, "CRITICAL CARE NURSES KNOWLEDGE OF EVIDENCE BASED GUIDELINES FOR PREVENTING -," no. October, 2007.
- [17] D. Carina, "Evaluation Portable / Transport Ventilators," no. March, pp. 74–93, 2010.
- [18] L. Acho, A. N. Vargas, and G. Pujol-Vázquez, "Low-Cost, open-source mechanical ventilator with pulmonary monitoring for COVID-19 patients," *Actuators*, vol. 9, no. 3, pp. 1–14, 2020, doi: 10.3390/act9030084.
- [19] J. Zuckerberg, M. Shaik, K. Widmeier, T. Kilbaugh, and T. D. Nelin, "A lung for all: Novel mechanical ventilator for emergency and low-resource settings," *Life Sci.*, vol. 257, no. June, p. 118113, 2020, doi: 10.1016/j.lfs.2020.118113.
- [20] A. Mohsen Al Hussein, H. Ju Lee, J. Negrete, S. Powelson, A. Tepper Servi, and A. H. Slocum, "Design and prototyping of a low-cost portable mechanical ventilator," *J. Med. Devices, Trans. ASME*, vol. 4, no. 2, pp. 1–1, 2010, doi: 10.1115/1.3442790.
- [21] S. H. Szal, "Design and Development of a Low- Cost Automatic Ventilator," no. April, 2020.
- [22] M. S. G. Tsuzuki *et al.*, "Mechanical Ventilator VENT19," *Polytechnica*, vol. 4, no. 1, pp. 33–46, 2021, doi: 10.1007/s41050-021-00031-z.
- [23] A. Mohsen Al Hussein, "MIT E-VENT | Emergency ventilator design toolbox," *Proc. 2010 Des. Med. Devices Conf.*, pp. 1–9, 2010, [Online]. Available: <https://e-vent.mit.edu/>

- [24] V. Kumar, R. Kumar, M. Kumar, G. S. Wander, V. Gupta, and A. Sahani, "Recent advances in low-cost, portable automated resuscitator systems to fight COVID-19," *Health Technol. (Berl)*, vol. 12, no. 1, pp. 181–191, 2022, doi: 10.1007/s12553-021-00629-4.
- [25] S. M. Ali, M. S. Mahmood, and N. S. Mahmood, "Design of a Low-Cost Ventilator to Support Breathing for Patients with Respiratory Failure Arising from COVID-19," *IOP Conf. Ser. Mater. Sci. Eng.*, vol. 1067, no. 1, p. 012143, 2021, doi: 10.1088/1757-899x/1067/1/012143.
- [26] R. M. Kacmarek, "The mechanical ventilator: Past, present, and future," *Respir. Care*, vol. 56, no. 8, pp. 1170–1180, 2011, doi: 10.4187/respcare.01420.



## DESIGN AND FABRICATION OF SEMI-AUTOMATED MACHINE VICE

Dhanush B M<sup>1</sup>, Chethan Kumar R<sup>1</sup>, Dhanaraj H D<sup>1</sup>, Anil Kumar A<sup>2</sup>

<sup>1</sup> Students, <sup>2</sup> Assistant Professor  
Department of Mechanical Engineering  
K.S. Institute of Technology Bangalore -560109

### ABSTRACT

The present paper represents the design and development of semi-automated machine vice. In this the work piece will be held and released automatically for the machining process with the help of pneumatic cylinder. When the workpiece is present between the jaw the IR sensors senses the workpiece and signal is fed to the circuit board, in the circuit board Arduino is present which controls the operating process, the pneumatic cylinder piston will move forward the moving jaw front and hold the workpiece rigidly. It reduces the human power, the jaw will move fast and hold the work piece, the drilling operation is carried out after the operation is carried out the jaw will return back to its position. Also increases the accuracy and the time utilization is reduced.

**Keywords:** Semi-Automated Machine Vice, Pneumatics, Arduino, IR Sensor, Solenoid Valve.

### 1. INTRODUCTION

A machine vice is a work holding device used to hold a work piece while operating it on a drill press or milling machine.

Work holding and releasing is the most essential act to carry out machining. These are commonly used in the machine shop[2]. Its main objectives are to hold the job in proper position, release the job quickly, hold the job rigidly, to prevent vibration of the job while the machining is carried out[6]. There are many types of work holding devices like machine vices swivel vices, universal vice, pipe vice, T-Bolt's 'U' clamps, Goose neck clamp, angle plate, Jigs and fixtures etc. These are all mechanical type work holding devices[1,3]. In the previous inventions the jaw was used to move by manual power where it had many disadvantages like time consuming, more human power to tight the work piece[8]. So, in this project we developed a machine vice which works by the use of air compressor using Arduino and sensor for the drilling operation. Here the loading and unloading is quick. The job can be held more rigidly.

### 2. COMPONENTS

To obtain the fabricated model the below mentioned components are used and they are explained as follows:

#### 2.1 Arduino Uno

Arduino Uno is a popular microcontroller development board based on 8-bit ATmega328P microcontroller. Along with ATmega328P MCU IC, it consists of other components such as crystal oscillator, serial communication, voltage regulator, etc. to support the microcontroller.



FIGURE 1: Arduino [11]

#### 2.2 IR Sensor Module

The IR sensor module consists mainly of the IR Transmitter and Receiver, Op-amp, Variable Resistor (Trimmer pot), output LED along with few resistors.

IR LED emits light, in the range of Infrared frequency. IR light is invisible to us as its wavelength (700nm – 1mm) is much higher than the visible light range. IR LEDs have light emitting angle of approx. 20-60 degree

and range of approx. few centimeters to several feet, it depends upon the type of IR transmitter and the manufacturer. Some transmitters have the range in kilometers.

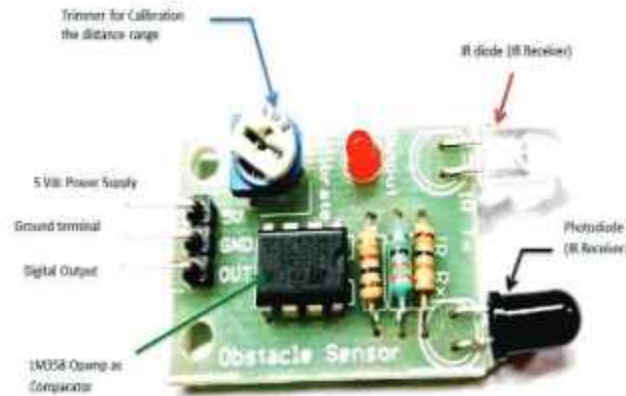

FIGURE 2: IR Sensor [12]

### 2.3 5V Dual-Channel Relay Module

The dual-channel relay module is more or less the same as a single-channel relay module, but with some extra features like optical isolation. The dual-channel relay module can be used to switch mains powered loads from the pins of a microcontroller. Dual-Channel Relay Module Specifications consists of: Supply voltage 3.75V to 6V, Trigger current – 5mA, Relay maximum contact voltage – 250VAC, 30VDC, Relay maximum current – 10A.

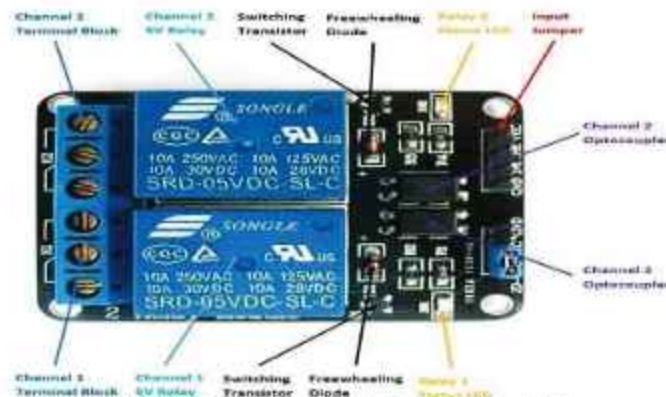

FIGURE 3: 2 Channel Relay Module [13]

### 2.4 Pneumatic Cylinder

Pneumatic cylinders are mechanical devices which use the power of compressed gas to produce a force in a reciprocating linear motion. It consists of pistons and cylinder. The cylinder is a Single acting cylinder one, which means that the air pressure operates forward and spring returns backward. The air from the compressor is passed through the regulator which controls the pressure to required amount by adjusting its knob. The piston is generally made up of Aluminium and is of medium work. The Pneumatic Cylinder is made up of Cast iron graded.



FIGURE 4: Pneumatic Cylinder [14]

### 2.5 Solenoid Valve

The Solenoid Valve is also known as Directional Valve is one of the important parts of a pneumatic system. Commonly known as DCV, this valve is used to control the direction of air flow in the pneumatic system. The directional valve does this by changing the position of its internal movable parts. It is of  $\frac{1}{2}$  inches and has the pressure of 0 to 7kg/cm<sup>2</sup>. It is the type of 5/2 Solenoid valve. It is made up of High-Speed Steel HSS.



FIGURE 5. Solenoid Valve [15]

### 2.6 PU Connectors, Reducer and Hose Collar

In our pneumatic system there are two types of connectors used, one is the hose connector and the other is the reducer. Hose connectors normally comprise an adapter (connector) hose nipple and cap nut. These types of connectors are made up of brass or Aluminium or hardened steel. Reducers are used to provide inter connection between two pipes or hoses of different sizes. These reducers are made up of gunmetal or other materials like hardened steel etc.



FIGURE 6. Connectors, Reducer and Hose Collar [16]

### 2.7 Stand

It generally consists of four legs and is made up of Mild Steel. It acts as supporting frame. The Pneumatic cylinder is clamped to the stand and the whole top body is mounted on it. The dimensions are 480x300x270mm and the thickness is 20mm.



FIGURE 7. Stand

### 2.8 Drill Motor

A drill is a tool used for making holes. This is connected to the DC motor which is mounted on the top of the model. When the Sensor senses the work piece present between the jaw the drill operation starts.



FIGURE 8:: Drill Motor [17]

### 2.9 Battery

The Lead-Acid Battery is used to start the model fabricated for working process. It is a type of rechargeable battery with a specification of 12V, 7.5A.



FIGURE 9. Battery

### 3. DESIGN AND ASSEMBLY

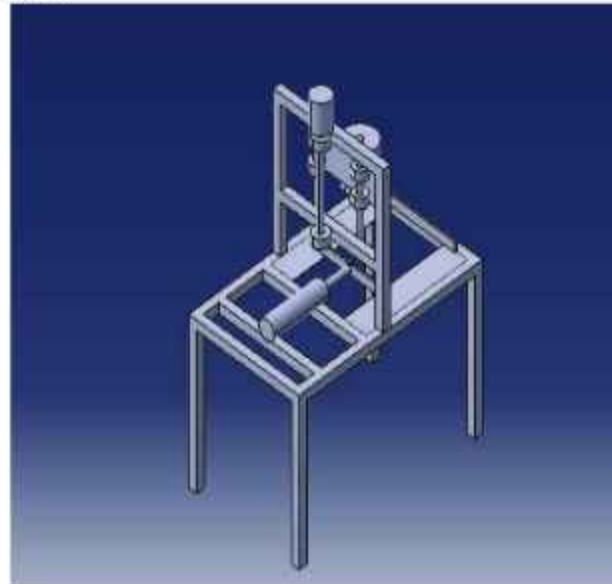

FIGURE 10. Isometric View of Fabricated Machine Vice

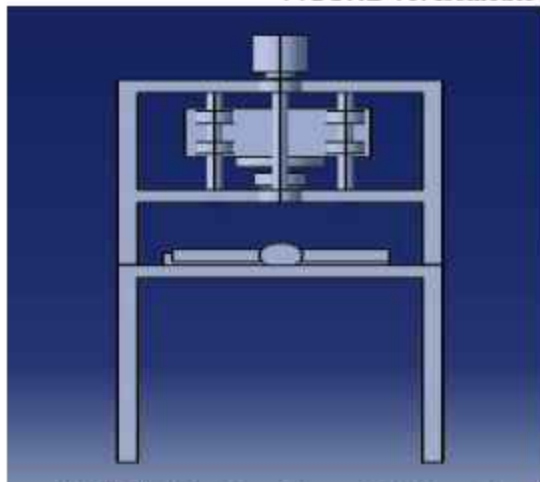

FIGURE 11:: Front View of Fabricated Machine Vice

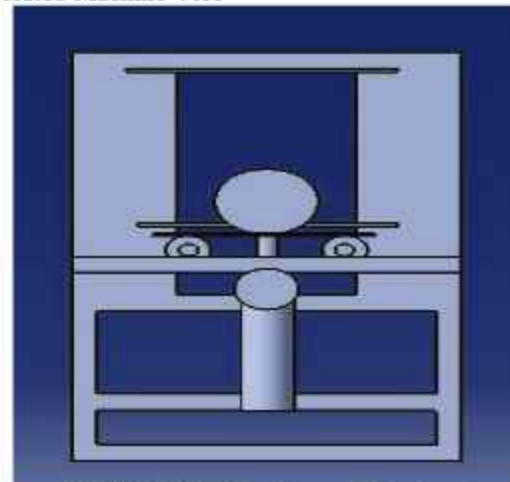

FIGURE 12: Top View of Fabricated Machine Vice

### 4. METHODS

All the components as per the specifications are procured. The design was carried out. As per the design specifications the frame was fabricated. On the frame the pneumatic cylinder was clamped where the cylinder

was tested successfully. To the cylinder piston a rectangular piece was welded which acts as the moving jaw. On the top of the frame a vertical frame was welded in which the drill motor battery was fixed. To the frame drill motor was fixed for the operation process. To move the drill up and down a screw shaft was welded and connected to the drill battery. Below the jaw a sensor is attached to indicate the presence of work piece. By using arduino a coding was done using Embedded C language. The circuit board was created on which 2 Dual-Channel Relay, Regulator, Arduino is present. To the circuit board the drill motor, sensor, solenoid valve was connected. After the finishing of the model it was tested successfully as shown in the figure 13.

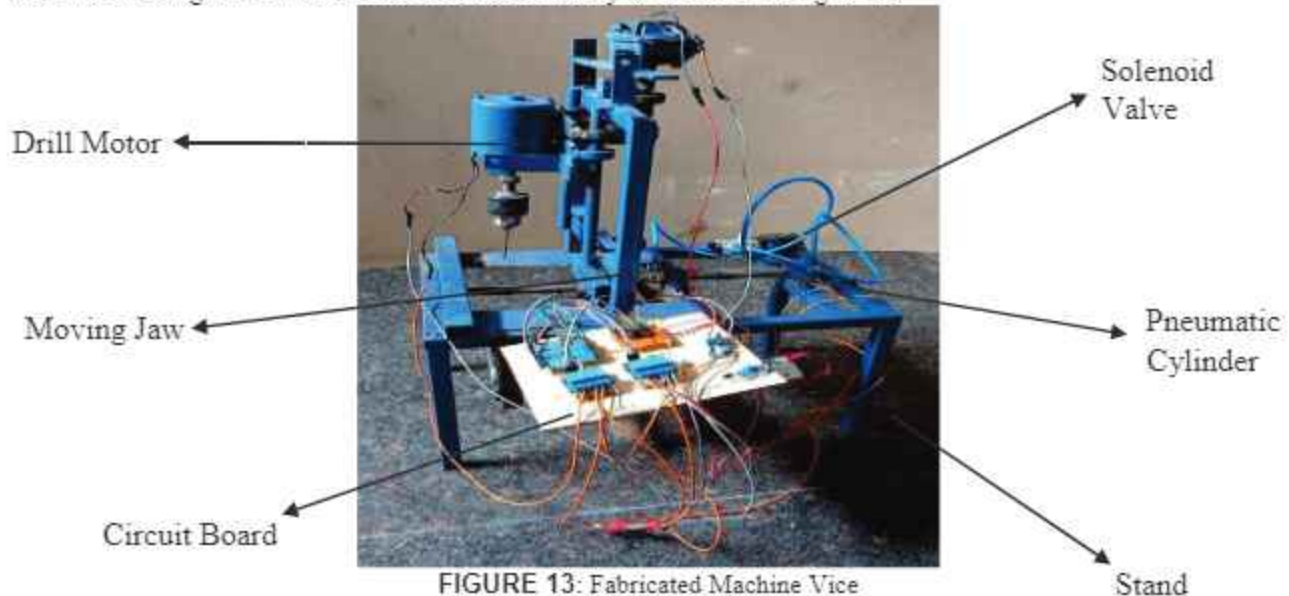

FIGURE 13: Fabricated Machine Vice

## 5. RESULTS & DISCUSSIONS

As per the standard specifications the machine vice is fabricated and tested. The size of the work piece mounted is 220x95x5mm. The maximum displacement the jaw can open is 130mm. The Sensor senses the work piece present between the jaws and indicates the circuit board to start the process. The solenoid valve allows the compressed air pass through the pneumatic cylinder where it moves forward clamping the work piece rigidly. The circuit board starts the drill motor in which the drilling operation is executed. After the operation is completed the jaw will unclamp the work piece.

## 6. CONCLUSIONS

Semi-Automated Machine Vice is fabricated according to the design specifications and it was tested by mounting a work piece of 220x95x5mm on which the drill operation was done successfully. With the help of mechanical motion obtained due to the application of pneumatic force the vice can be clamped. By this, it reduces the human power. The jaw will move faster and holds the work piece and it returns back to its position. Also this increases the accuracy and the time utilization is reduced.

## ACKNOWLEDGMENTS

We would like to express our gratitude to our Student Project Coordinator, Dr. Nirmla L, for having given this opportunity and support to carry out our project work.

## REFERENCES

- [1]. Anuchandran C, Praveen M, Karthikeyan R, Arun R, K Marimuthu, "Design and Fabrication of Automatic Machine Vice using Microcontroller", IJSRD - International Journal for Scientific Research & Development Vol. 5, Issue 07, 2017.
- [2]. P Sivasankaran, Thiyagarjan M, Vignesh N, Ajith Kumar A, "Design and Optimization of assembly time of screw less machine vice using FDA approach", International Journal of engineering and management research volume -7, Issue-5, September - October 2017.
- [3]. Essam Ali Al-Bahkali, Adel Taha Abbas, Failure analysis of vise jaw holders for hacksaw machine", Department of Mechanical Engineering, Engineering College, King Saud University, P.O. Box 800, Riyadh 11421, Saudi Arabia received 1 September 2015; accepted 23 December 2015.
- [4]. K ViswanathAllamraju, Rithvik Reddy Polusani, Vutakuri Sai Ranganath, Banda Venkateshwar Reddy, Ambati Pavan Kumar, "Design for Manufacturing and Analysis of Motorized Bench Vice", International Journal of Innovative Technology and Exploring Engineering (IJITEE) ISSN: 2278-3075, Volume-9 Issue-7, May 2020.

- [5]. Dr. S K Patel, "Design and fabrication of holding work piece for Drilling and milling purpose", Department of mechanical NIT Rourkela – 769008, 2013-2014.
- [6]. P Sivasankaran, "Design and Analysis of Modular Fixture for Machine Vice", International Journal of Industrial & Production Engineering & Technology. ISSN 2249-4219 Volume 8, Number 1 (2018).
- [7]. Asst. Professor, Dept. of Mechanical Engg Dr. Babasaheb Ambedkar, "Manufacturing of Components of Modified Bench Vice on Rapid Prototype Machine", International Journal of Application or Innovation in Engineering & Management (IJAIEM).
- [8]. Prof. Rushikesh D Sonar, Milind Y Patil, Karan B Bandawane, Vaibhav A Bhandare, Darshan M Chaudhai, "Pneumatic Operated Vice and Jack", IJARIE-ISSN(O) Vol-6 Issue-2 2020.
- [9]. Prof. Jatin Gulati, Dhananjay Kumar, Sagar Gupta, "Pneumatic Bench Vice Model, Department of Mechanical & Automation Engineering", G B Pant Government Engineering College, New Delhi-110020, November 2012.
- [10]. Prof. Priyanka Chavan, Shwetha Desale, Gayatri Fegade, Meghana Kakade, Prajakta Bhosale, "Review on Machine Vice and detailed study of Hydraulic Machine Vice", Department of Mechanical Engineering, Pimpri Chinchwad College of Engineering & Research, Maharashtra, India.

## DESIGN AND FABRICATION OF SOIL MOISTURE SENSING ROBOT

Hemanth Kumar M P<sup>1</sup>, Kaushal S<sup>1</sup>, Nilotpal Das<sup>1</sup>, Yogesh H M<sup>1</sup>, Manjunath B R<sup>2</sup>

<sup>1</sup> Students, <sup>2</sup> Assistant Professor  
Department of Mechanical Engineering  
K.S. Institute of Technology Bangalore -560109

### ABSTRACT

*Our country India is an agricultural country. Almost 64.9% of people are dependent on the agriculture but due to abrupt climate change and global warming the farmer are not able to provide proper nutrition and minerals to the plants which can be obtained from irrigation. So In this project we are designing and fabricating the soil moisture sensing robot. "Soil moisture sensing robot" is automated irrigation vehicle using Arduino microcontroller (ESP8266) system which is cost effective and can be used farm field. The proposed system is developed to automatically water the plants when the soil moisture sensor will detect the soil is insufficient of water by using the Arduino as the centre core. The soil moisture sensing robot is a fully functional prototype which consist of soil moisture sensor, the android phone is used to display the whether the soil is hydrated or not and the pump status. The application (blynk) is used to control the on/off switch of the water pump. When the soil moisture sensor senses the dry soil, it will show the weather the soil is hydrated or not in the android phone, and the application will switch on the water pump automatically to start the watering process and vice versa.*

**Keyword:** -Arduino, Microcontroller, Pump, Android phone

### 1. INTRODUCTION

Irrigation is the major part in the agriculture. Manual watering of the plants in the farming field requires more time and labour. In last few years many devices and technologies are been used by the farmer to provide automation in the farming which reduces the effort and can be time consuming for them. The purpose of making the project is to build soil moisture sensing robot which is able to detect whether the soil is hydrated or not, whatever the result is achieved it is displayed on the screen of the phone. If the soil is not hydrated then it will show the message that it is not hydrated after this use of pump come into the picture

Microcontroller based soil moisture sensing robot allows a simple and low cost method for irrigating the crops the crops automatically. In the proposed system we use application (blynk) to display the information. In this project we are using soil moisture sensor for

irrigation purpose. In the project we are using Arduino Uno controller.

For wireless communication, the hotspot of the phone

is turned ON which transmit status of sensor as well as receives the command from phone to turn ON and OFF the motor pump.



FIGURE 1. Soil moisture sensor

## 2. COMPONENTS

The components used in this project are:

### 2.1 DC Electric Motor

Dc motor or direct current (Fig 2) motor is a electrical machine which transforms electrical energy into mechanical energy. Dc motors are used in the application where high starting torque is required, and accurate speed control over variable voltage take place. The capacity of motor used in project is 60 rpm



FIGURE 2. DC Electric motor

### 2.2 Node Microcontroller unit (MCU):

Node MCU is an open source platform based on ESP8266 which can connect objects and data transfer using the wifi control. The programming code is written for ESP8266 wifi chip using Arduino IDE, for which installation of ESP8266 libraries is needed



FIGURE 3. Node Microcontroller unit



### 2.3 Lead acid battery:

Lead acid battery is the most commonly used battery which has long lifetime and low cost compared to other type of battery. They are used in back-up power supplies for smaller computer system and many more. The capacity of battery which we are using in the project is 6 V, 5 AH



FIGURE 4 .Lead acid battery

### 2.4 Arduino Uno

Arduino Uno is an open source hardware and software platform that is easy to use. Arduino boards are capable of reading analog or digital input signals from various sensors.



FIGURE 5.Arduino Uno

### 2.5 Soil Moisture Sensor:

Soil moisture sensor measure the water content in the soil and can be used to estimate the amount of water stored in the soil. It doesn't measure the moisture directly, it measure the change in some other soil property that is related to water content.

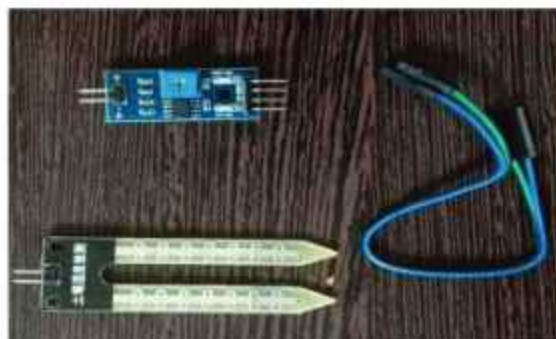

FIGURE 6. Soil moisture with module

### 3. METHODOLOGY



FIGURE 7. Using the component the product is assembled

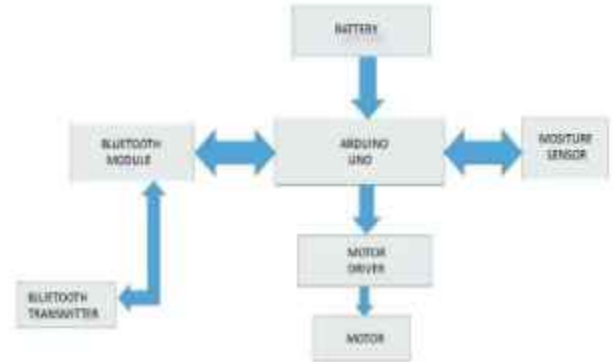

FIGURE 8. Block diagram

- ❑ Initially the battery (lead acid) is used to switch ON the system, once the system is On Arduino Uno start to operate.
- ❑ Since all the instruction (Input) are inserted in the Arduino Uno it will control the working of Bluetooth module as well as Moisture Sensor.
- ❑ Moisture sensor is used to detect the whether the soil is hydrated or not.
- ❑ Bluetooth module (hotspot) is used to transmit the message on the screen of the user.
- ❑ If the soil is not hydrated then watering in the soil can be done by the help of pump.
- ❑ The motor driver acts as the interface between the motor and control circuit (Arduino Uno) whatever the instruction is provided the motor driver help motor to work according to it.

### 4. RESULT

The soil moisture connected to an Arduino which is in turn interface with android application using Wi-Fi shield. Soil moisture is continuously monitored by sensor and the output displayed on the screen.

### 5. CONCLUSIONS

The introduced automated system is able to reduce the man efforts, wastage of water as well as power consumption and helps in obtaining good yield. The Bluetooth controlled (hotspot) is helpful in detecting the status of the soil by sitting away from the field. Soil moisture sensor helps in providing the better irrigation system and good crops with fewer inputs.

### REFERENCES

- [1] J. M. Corchado, J. Bajo, D. I. Tapia, and A. Abraham, —Using heterogeneous wireless sensor networks in a telemonitoring system for healthcare, | IEEE Trans. Inf. Technol. Biomed., vol. 14, no. 2, pp. 234–240, Mar. 2010. G.
- [2] X. Lee, K. S. Low, and T. Taher, —Unrestrained measurement of arm motion based on a wearable wireless sensor network, IEEE Trans. Instrum. Meas., vol. 59, no. 5, pp. 1309–1317, May 2010.
- [3] D.-M. Han and J.-H. Lim, —Smart home energy management system using IEEE 802.15.4 and ZigBee, | IEEE Trans. Consum. Electron., vol. 56, no. 3, pp. 1403–1410, Aug. 2010.
- [4] C. Gomez and J. Paradells, —Wireless home automation networks: A survey of architectures and technologies, | IEEE Commun. Mag., vol. 48, no. 6, pp. 92–101, Jun. 2010.

## DESIGN AND FABRICATION OF AIR BRAKE SYSTEM USING IC ENGINE EXHAUST GAS

Shrinidhi D<sup>1</sup>, Swasthik D K<sup>1</sup>, Uday Kiran P<sup>1</sup>, Ujwal N<sup>1</sup>, Dr. Saleem Khan<sup>2</sup><sup>1</sup> Students, <sup>2</sup> Assistant professor  
Department of Mechanical Engineering,  
K.S. Institute of Technology, Bengaluru, Karnataka.**ABSTRACT**

The aim of this project is to design and fabricate an Air Brake System based on Exhaust gases of an IC engine. The main objective is to reduce the workloads of the engine drive to operate the air compressor, because the compressor is not operated by the engine drive. A turbine is placed in the path of exhaust from the engine. The turbine is connected to a dynamo by means of coupling, which is used to generate power. Depending upon the airflow the turbine will start rotating, and then the dynamo will also start to rotate. A dynamo is a device which is used to convert the kinetic energy into electrical energy. The generated power can be stored in the battery and then this electric power has loaded to the DC compressor. The air compressor compresses the atmospheric air and it stored in the air tank and the air tank has pressure relief valve to control the pressure in the tank. The air tank supplies the compressed pneumatic power to the pneumatic actuator through solenoid valve to apply brakes. The pneumatic actuator is a double acting cylinder which converts pneumatic pressure into linear motion. The generated electric power from the turbine used to compress the air in the DC compressor then supplied the pneumatic power to the air braking system. The exhaust gas was effectively utilized to perform the air braking system in addition to the conventional braking system and found the improvement in the braking performance.

**Keyword:** Air Brake, Exhaust, Pneumatic actuator, Dynamo, Solenoid valve, Kinetic energy.

**1. INTRODUCTION**

A brake is a mechanical device that inhibits motion by absorbing energy from a moving system. It is used for slowing or stopping a moving vehicle, wheel, axle, or to prevent its motion, most often accomplished by means of friction.

Most brakes commonly use friction between two surfaces pressed together to convert the kinetic energy of the moving object into heat, though other methods of energy conversion may be employed. For example, regenerative braking converts much of the energy to electrical energy.

Friction brakes on automobiles store braking heat in the drum brake or disc brake while braking then conduct it to the air gradually. When traveling downhill some vehicles can use their engines to brake.

An air brake or, more formally, a compressed air brake system, is a type of friction brake for vehicles in which compressed air pressing on a piston is used to apply the pressure to the brake pad needed to stop the vehicle. Air brakes are used in large heavy vehicles, particularly those having multiple trailers which must be linked into the brake system, such as trucks, buses, trailers, and semi-trailers in addition to their use in railroad trains [1].

**2. MATERIALS AND METHODOLOGY****2.1 ENGINE**

As shown in figure 2.1, an engine is a machine designed to convert chemical energy into useful mechanical motion. Heat engines, including internal combustion engines and external combustion engines (such as steam engines) burn a fuel to create heat, which then creates motion. The internal combustion engine is classified into two types and they are diesel engine and petrol engine. Originally, an engine was a mechanical device that converted force into motion [3].

In this project, we use 59.9cc Spark Ignition four stroke single cylinder engine. It consists of a piston that moves within the cylinder fitted with two valves. The distance moved in one direction is called stroke and the cylinder diameter is bore. The piston is said to be at the top dead centre position the volume of the cylinder is minimum.



Fig 2.1, IC Engine

**2.2 AIR BRAKE SYSTEM**

Air brake systems are typically used on heavy trucks and buses. The system consists of service brakes, parking brakes, a control pedal, and an air storage tank. For the parking brake, there's a disc or drum brake arrangement which is designed to be held in the 'applied' position by spring pressure. Air pressure must be produced to release these "spring break" parking brakes. For the service brakes (the ones used while driving for slowing or stopping) to be applied, the brake pedal is pushed, routing the air under pressure (approx. 100–120 psi or 690–830 kPa or 6.89–8.27 bar) [7] to the brake chamber, causing the brake to be engaged. Most types of truck air brakes are drum brakes, though there is an increasing trend towards the use of disc brakes in this application. Figure 2.2 shows the nomenclature of a typical air brake system.

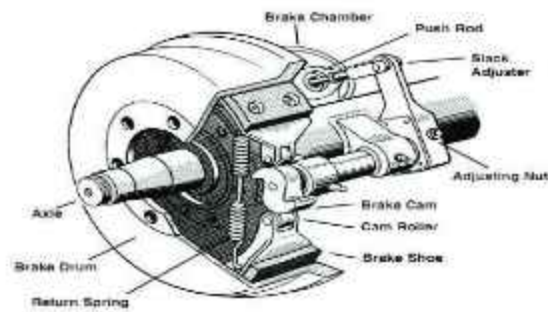

Fig 2.2, Air brake system.

### 2.3 AIR COMPRESSOR

Figure 2.3 shows an air compressor which is a device that converts power (using an electric motor, diesel or gasoline engine, etc.) into potential energy stored in pressurized air (i.e., compressed air). By one of several methods, an air compressor forces more and more air into a storage tank, increasing the pressure. When tank pressure reaches its engineered upper limit the air compressor shuts off. The compressed air, then, is held in the tank until called into use. The energy contained in the compressed air can be used for a variety of applications, utilizing the kinetic energy of the air as it is released and the tank depressurizes. When tank pressure reaches its lower limit, the air compressor turns on again and re-pressurizes the tank.

An air compressor must be differentiated from an air pump which merely pumps air from one context (often the surrounding environment) into another (such as an inflatable mattress, an aquarium, etc.). Air pumps do not contain an air tank for storing pressurized air and are generally much slower, quieter, and less expensive to own and operate than an air compressor. The compressor that we are using in the project has a capacity to withstand 300psi of pressure.



Fig 2.3, Air compressor

### 2.4 PNEUMATIC CYLINDER

As shown in figure 2.4, a pneumatic cylinder(s) (sometimes known as air cylinders) are mechanical devices which use the power of compressed gas to produce a force in a reciprocating linear motion.

Like hydraulic cylinders, something forces a piston to move in the desired direction. The piston is a disc or cylinder, and the piston rod transfers the force it develops to the object to be moved. Engineers sometimes prefer to use pneumatics because they are quieter, cleaner, and do not require large amounts of space for fluid storage.

Because the operating fluid is a gas, leakage from a pneumatic cylinder will not drip out and contaminate the surroundings, making pneumatics more desirable where cleanliness is a requirement.



Fig 2.4, Pneumatic cylinder.

### 2.5 SOLENOID VALVE

A solenoid valve is an electromechanically operated valve. The valve is controlled by an electric current through a solenoid; in the case of a two-port valve the flow is switched on or off, in the case of a three-port valve, the outflow is switched between the two outlet ports. Multiple solenoid valves can be placed together on a manifold.

Solenoid valves are the most frequently used control elements in fluidics. Their tasks are to shut off, release, dose, distribute or mix fluids. They are found in many application areas. Solenoids offer fast and safe switching, high reliability, long service life, good medium compatibility of the materials used, low control power and compact design [5].

Besides the plunger-type actuator which is used most frequently, pivoted-armature actuators and rocker actuators are also used.



Fig 2.5, Solenoid valve.

## 2.6 BATTERY

A rechargeable battery, storage battery, secondary cell, or accumulator is a type of electrical battery which can be charged, discharged into a load, and recharged many times, as opposed to a disposable or primary battery, which is supplied fully charged and discarded after use. It is composed of one or more electrochemical cells. The term "accumulator" is used as it accumulates and stores energy through a reversible electrochemical reaction. Rechargeable batteries are produced in many different shapes and sizes, ranging from button cells to megawatt systems connected to stabilize an electrical distribution network. Several different combinations of electrode materials and electrolytes are used, including lead-acid, nickel-cadmium (Ni-Cd), nickel-metal hydride (NiMH), lithium-ion (Li-ion), and lithium-ion polymer (Li-ion polymer). Figure 2.6 shows a typical rechargeable battery.



Fig 2.6, Battery

## 2.7 PNEUMATIC PIPES

Pneumatic tubes (or capsule pipelines; also known as pneumatic tube transport or PTT) as shown in figure 2.7, are systems that propel cylindrical containers through networks of tubes by compressed air or by partial vacuum. They are used for transporting solid objects, as opposed to conventional pipelines, which transport fluids. Pneumatic tube networks gained acceptance in the late 19th and early 20th centuries for offices that needed to transport small, urgent packages (such as mail, paperwork, or money) over relatively short distances (within a building, or at most, within a city). Some installations grew to great complexity, but were mostly superseded. In some settings, such as hospitals, they remain widespread and have been further extended and developed in the 21st century. We have used 8mm pneumatic pipes currently for the passage of air into the cylinder in order to actuate the movement.



Fig 2.7, Pneumatic pipes.

## 2.8 DYNAMO

Dynamo is an electrical generator. This dynamo produces direct current with the use of a commutator. Dynamo was the first generator capable of generating power in the industries. The dynamo uses rotating coils of wire and magnetic fields to convert mechanical rotation into a pulsing direct electric current. A dynamo machine consists of a stationary structure, called the stator, which provides a constant magnetic field, and a set of rotating windings called the armature which turn within that field. On small machines the constant magnetic field may be provided by one or more permanent magnets, larger machines have the constant magnetic field provided by one or more electromagnets, which are usually called field coils. The commutator was needed to produce direct current. When a loop of wire rotates in a magnetic field, the potential induced in it reverses with each half turn, generating an alternating current. However, in the early days of electric experimentation, alternating current generally had no known use. The few uses for electricity, such as electroplating, used direct current provided by messy liquid batteries. Dynamos were invented as a replacement for batteries. The commutator is a set of contacts mounted on the machine's shaft, which reverses the connection of the windings to the external circuit when the potential reverses, so instead of alternating current, a pulsing direct current is produced.

## 2.9 METHODOLOGY

An IC engine powered by petrol is used to produce exhaust gas. Here we are placing a turbine in the path of exhaust from the silencer. The turbine is connected to a dynamo, which is used to generate power.

Depending upon the airflow the turbine will start rotating thus rotating the dynamo. A dynamo is a device which is used to convert the kinetic energy into electrical energy. The generated electric power is stored in a battery after rectification. Thus, the stored electrical power is used to run the DC compressor. The compressor compresses the air from the exhaust. When the brake is applied the 5/2 solenoid valve is activated and it allows the air to actuate the pneumatic cylinder thus the brake is applied [1]. Figure 2.9 shows the block diagram of the workflow of the project.

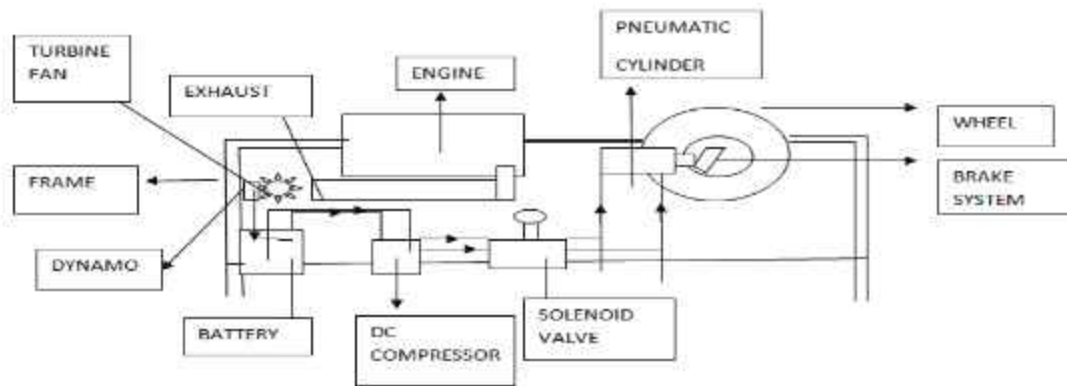

Fig 2.9. Block diagram.

### 3. RESULTS AND DISCUSSIONS

The temperature and pressure increase when the load is increased depending upon the operating conditions. Pressure and temperature will vary depending on load conditions as well as voltage will vary. Therefore, the voltage should be checked by using a multi-meter. The voltage is measured by using a multi-meter during variable condition. The below calculation is calculated based on the literature survey. The battery is used for charging and it is tested. Voltage is measured by using a voltmeter. The current is measured by ammeter while energy is recovered from the exhaust gas. The area of turbine is measured and calculated on the basis of design criteria. The power available at the turbine is calculated by below formula.

#### Formula:

$$\text{Swept Area, } A = \pi r^2$$

$$R = \text{radius of turbine} = 27.5 \times 10^{-2} \text{ m}$$

$$\text{Velocity of the Turbine} = (\pi \times D \times N) / 60$$

Where,

$$D = \text{turbine diameter} = 55 \times 10^{-2} \text{ m}$$

$$N = \text{rpm}$$

$$C_p = \text{power co-efficient}$$

Turbine power,

$$P = \left(\frac{\rho}{2}\right) \times \text{Density} \times (\text{Velocity})^3 \times C_p \times \text{Area}$$

#### Model Calculation:

Swept area (turbine),

$$A = \pi r^2$$

$$= \pi \times (27.5 \times 10^{-2})^2$$

$$= 2.37 \times 10^{-2} \text{ m}^2$$

Velocity of the turbine, Velocity

$$= \frac{\pi \times D \times N}{60}$$

$$= \frac{\pi \times 55 \times 10^{-2} \times 95}{60}$$

$$= 0.2735 \text{ m/s}$$

Power available at the turbine

$$= \left(\frac{\rho}{2}\right) \times \text{Density} \times \text{Area} \times (\text{Velocity})^3 \times C_p = 0.5 \times 1.25 \times 2.37 \times 10^{-2} \times (0.2735)^3 \times 0.5 = 1.51 \times 10^{-2} \text{ watts}$$

### 4. CONCLUSION

The above calculation show the result of our project i.e. in the 1<sup>st</sup> trial at RPM 1500 the dynamo rotated at the speed of an RPM 95. And power generate was  $1.51 \times 10^{-2}$  watts. We can conclude that whenever RPM of the engine is increased RPM of the dynamo will also increase and power generation will be more. We can also recover the energy that is being discharged from the exhaust gas without any change in performance.

#### REFERENCES

- [1] Srinivasa D, Karthik S T, Deepak M, Gowtham M, Sagar AS - Development and fabrication of air brake system using engine exhaust gas- IOSR Journal Of Mechanical and Civil Engineering, Vol. 16 Issue-3 June 2019.
- [2] Harsha B T, G Rajesh, Arun Kumar K, Akash S M, Preethi Raddymasi - Fabrication of air brake system using engine exhaust gas - International journal for technological research in engineering, Vol 6, Issue 9, May 2019
- [3] N Abhishek, S Arul Prakash, S Manikandan, T P Suresh- Design and Fabrication of air brake system using engine exhaust gas- International research Journal of Engg. & Technology [IRJET] Vol. 8 Issue-4, April 2021.
- [4] Sethuraman B L, Sakthivel R, Gopal Krishnan E, Shree Ram Vishal- Design and implementation of secondary air brake system using engine exhaust gas- Journal of advanced engineering research, Vol 7, Issue 2 (2020)
- [5] S Suresh, J D Nallashivam, A Thrimoorthy- Pneumatic braking System- International journal of production technology and management (IJPTM) Vol 9, Issue 2, December 2018
- [6] Md. Afab Ali, Sanam Kothari, Krutnag Jariwala, Ratnadiip Bhorge- Design and fabrication of air brake system using engine exhaust gas - Journal of thermal energy system vol.4 Issue 2 (2019)

## COMPUTATIONAL FLUID DYNAMICS ANALYSIS OF BLADES FOR VERTICAL AXIS WIND TURBINE

Janardhan R<sup>1</sup>, Tejas A B<sup>1</sup>, Sharan V K<sup>1</sup>, Sankarshan D<sup>1</sup>, Dr Saleem Khan<sup>2</sup>

<sup>1</sup>Students, <sup>2</sup>Associate Professor

Department of Mechanical Engineering,

K S Institute of Technology, Bangalore-560109, Karnataka, India

### ABSTRACT

*This paper deals with alternate source of energy, since there is a scarcity of conventional energy resources now a days, there is a need for developing and usage of renewable energy resource. In this work an attempt has been made to convert the energy released by people while driving around in city or highways. Here vehicles acts as the power source and the vertical axis wind turbine acts as source of power generation. Energy can be harvested using vertical axis wind turbines (VAWT) placed on the sides of the highways to make use of the vehicles moving in both directions. This work presents an experimental study of using a three-bladed helical VAWT specially designed and manufactured for producing electrical energy from wind energy of moving cars on highways for lighting purposes such as the highway lights, traffic signals, and light guide lines.*

**Keywords:** Source of energy, conventional, renewable, highways, vertical axis wind turbine

### 1. INTRODUCTION

Energy can be defined as the ability to do work. Modern civilization is possible because people have learned how to change energy from one form to another and then use it to do work. People use energy to walk and bicycle, to move cars along roads and boats through water, to cook food on stoves, to make ice in freezers, to light our homes and offices, to manufacture products, and to send astronauts into space.

These forms of energy can be grouped into two general types of energy for doing work:

- Potential or stored energy
- Kinetic or working energy

Energy can be converted from one form to another. For example, the food a person eats contains chemical energy, and a person's body stores this energy until he or she uses it as kinetic energy during work or play. The stored chemical energy in coal or natural gas and the kinetic energy of water flowing in rivers can be converted to electrical energy, which in turn can be converted to light and heat. There are many different sources of energy, which can be divided into two basic categories:

Renewable energy sources.

Non-renewable energy sources,

#### Wind turbine

Motivation for designing a vertical axis wind turbine is to contribute towards the global trend in wind energy production in a feasible way. Wind turbines are traditionally employed in rural areas; the goal of this research is to design a vertical axis wind turbine that can be used in cities. In particular, the turbines will use the wind draft created by vehicles on the highway to generate electricity. The idea is to offset the amount of pollution created by burning fossil fuels by introducing a potential source of clean energy.

The vertical wind turbine design is selected because they are capable of capturing wind in any direction. The helical blade shape of the wind turbine is much quieter than the turbine with traditional blades, because they have slower speed along the blade tip. They are easy to install, they have low maintenance cost, and pose low risk for human and birds because the blades move at relatively low speed. They can be placed lower to the ground and rooftops, and have high efficiency because the helical blades design gets higher wind capture. Therefore, in this research a three-bladed helical VAWT prototype is designed and implemented on the Kuwait highway King Fahad Bin Abdul Aziz. This is one of Kuwait's high traffic roads where the demand for the lighting electric power is high.

### 2. METHODOLOGY

- Initially the natural wind speed in a particular location was observed for a week in order to design a wind turbine.
- Considering wind direction and velocity of wind, 5 blade geometric profiles were considered to see which suitable for the application.

- CFD analysis is conducted on selected 5 blade geometric profiles with suitable boundary conditions.
- There are three boundary conditions to be considered while conducting CFD analysis for the particular problem and they are:
  - Inlet condition
  - Wall boundary condition
  - Outlet condition
- Constant wind velocity of 1m/s is applied on all the types of blades while simulating.
- The pressure, velocity and direction of wind are tabulated.

Blade Type 1:

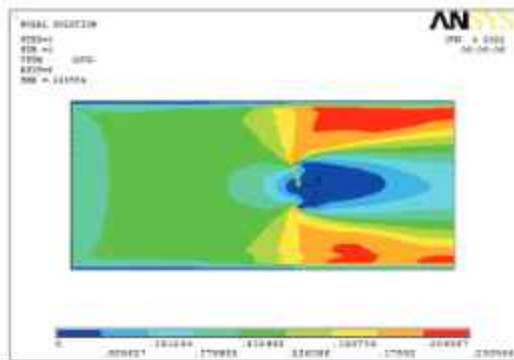

FIGURE 1: Velocity plot

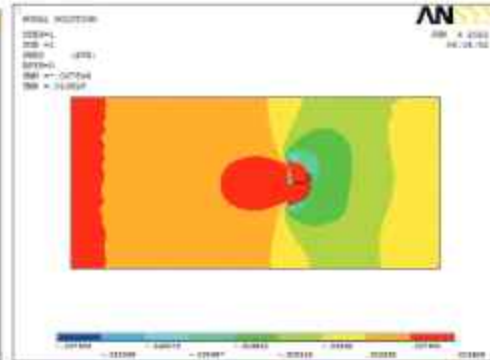

FIGURE 2: Pressure Plot

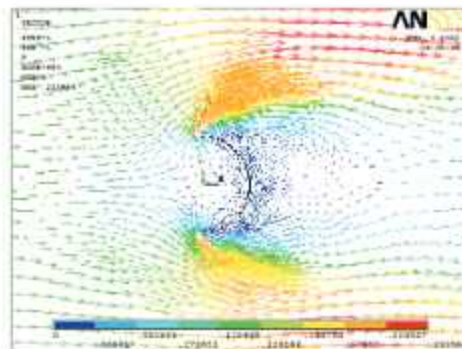

FIGURE 3: Vector plot

Blade Type 2:

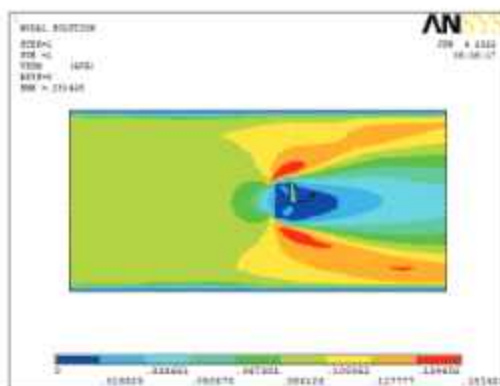

FIGURE 4: Velocity plot

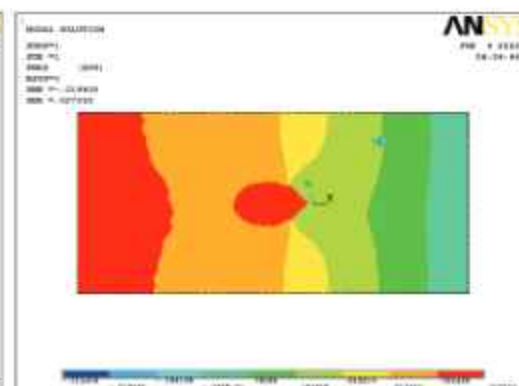

FIGURE 5: Pressure Plot



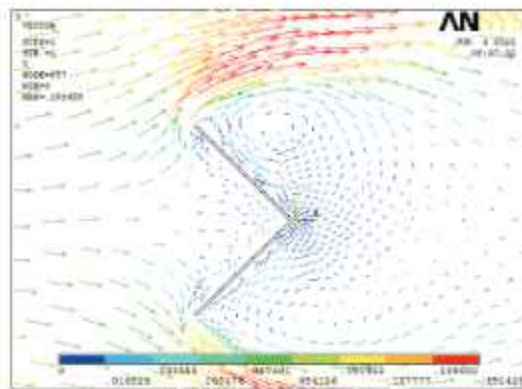

FIGURE 6: Vector plot

Blade Type 3:

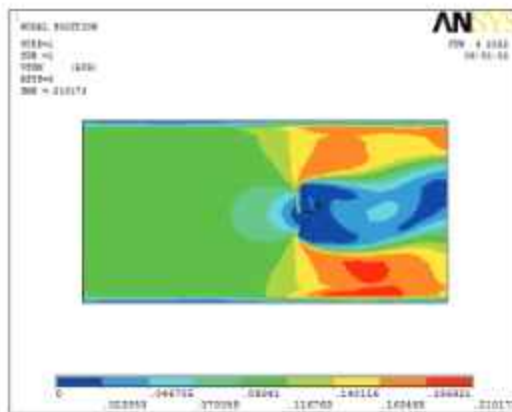

FIGURE 7: Velocity plot

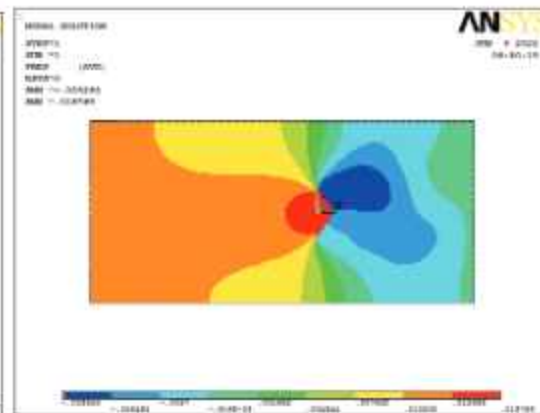

FIGURE 8: Pressure Plot

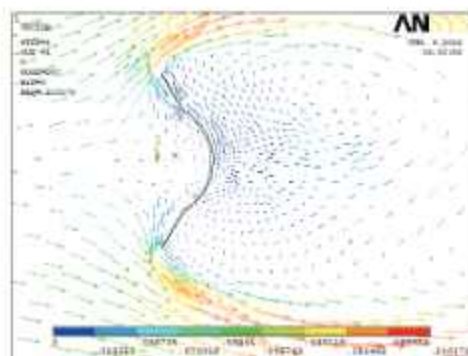

FIGURE 9: Vector plot

Blade Type 4:

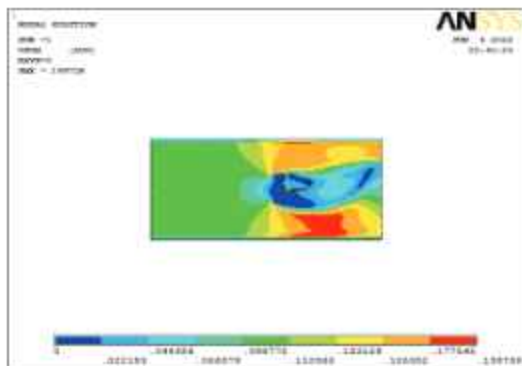

FIGURE 10: Velocity plot

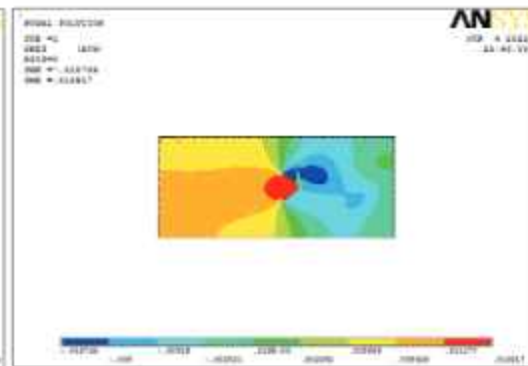

FIGURE 11: Pressure Plot

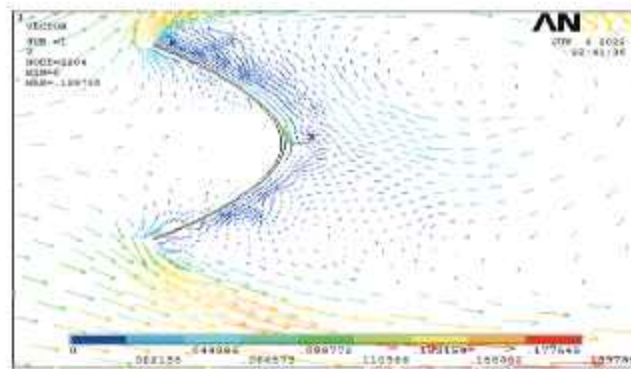

FIGURE 12: Vector plot

Blade Type 5:

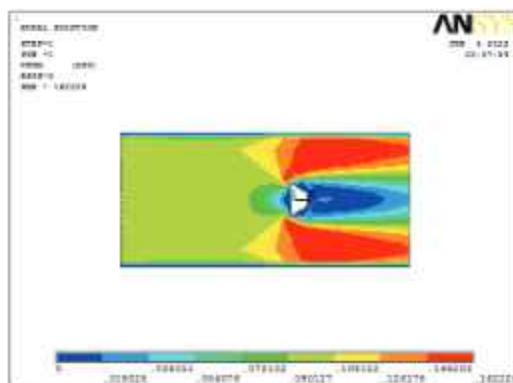

FIGURE 13: Velocity plot

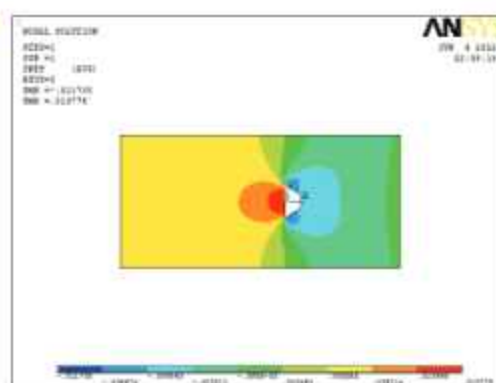

FIGURE 14: Pressure Plot

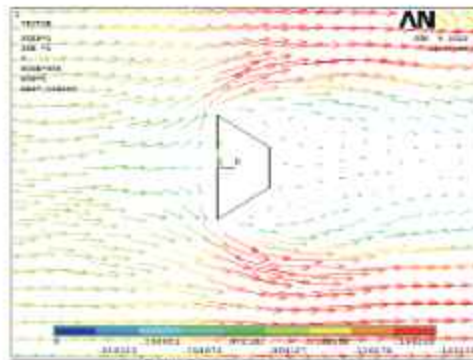

FIGURE 15: Vector plot

### 3. RESULTS AND DISCUSSION

TABLE 1

| SL NO | BLADE TYPE | VELOCITY m/s | PRESSURE N/mm |
|-------|------------|--------------|---------------|
| 1     | Blade 1    | 0.230        | 0.0136        |
| 2     | Blade 2    | 0.151        | 0.027         |
| 3     | Blade 3    | 0.210        | 0.0157        |
| 4     | Blade 4    | 0.199        | 0.0139        |
| 5     | Blade 5    | 0.162        | 0.0137        |

Graph 1

Graph 2



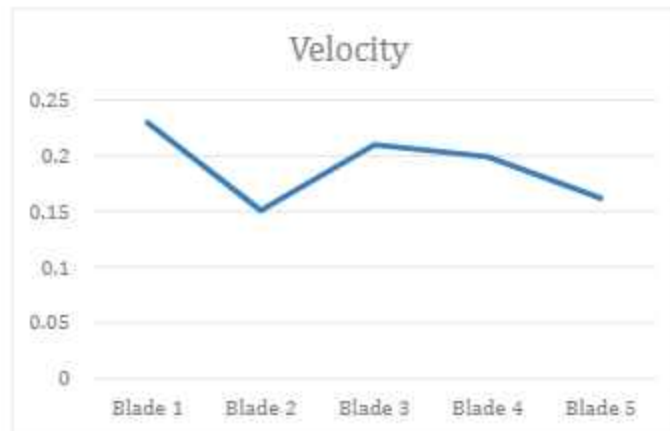

The blade was designed and analyzed using Computational Fluid Dynamics (CFD) by plotting velocity, pressure distribution and streamline flow. We could conclude that the velocity is considerably high in blade type 1 (from table 1). The pressure in blade 2 was found to be more (from table 1), since our project is based on velocity we could conclude that blade type one is most efficient and can capture maximum amount of wind.

## REFERENCES

- [1] MR.BRUCE CHAMPAGNIE, MR. GEATJENS ALTENOR, MR.ANTONIA SIMONIS, Highway Wind Turbines, Florida international university, published on April 12, 2013.
- [2] MOHAMMAD MIYAN, M. K. SHUKLA, Review on Non-Conventional Energy Resources in India, SAMRIDDHI A Journal of Physical Sciences Engineering and Technology, Vol. 10, Issue 2, Published on 16th Nov., 2018.
- [3] W.S. BANNISTER, S. GAIR, Energy for Rural and Island Communities, Published in proceeding of conference, held at Inverness, Scotland Published in March 2019.
- [4] MUHD KHUDRI JOHARI, MUHAMMAD AZIM A JALIL, MOHAMMAD FAIZAL MOHD SHARIFF, MUHD KHUDRI JOHARI MUHAMMAD AZIM A JALIL MOHAMMAD FAIZAL MOHD SHARIFF, Comparison of horizontal axis wind turbine and vertical axis wind turbine, International Journal of Engineering and Technology Published on 13<sup>th</sup> April, 2018.
- [5] R.SATHYANARAYANAN, MPRASATH, S.MUTHAMILZH, K.T.GOPINATH, The design, development and testing Highway windmill, INDIAN INSTITUTE of ELECTRICAL & ELECTRONICS ENGG., Published in year 2009.
- [6] NABEEL B, FIROZ KHAN T S, KRISHNARAJ V, KANNAN RAJ, ARUN S, SHAJU MON T K, AKHIL GANESH, Highway Helical Wind Turbine Project, Younus college of engineering and technology, May 17, 2010.
- [7] SAURABH ARUN KULKARNI1 & PROF. M.R. BIRAJDAR Vertical Axis Wind Turbine for Highway Application Imperial Journal of Interdisciplinary Research (IJIR) Vol-2, Issue-10, 2016.

## FABRICATION OF HORIZONTAL CENTRIFUGAL CASTING MACHINE FOR DEVELOPMENT OF AL6061 FUNCTIONALLY GRADED MATERIAL

Kuppala Akhileswr<sup>1</sup>, Devendra G<sup>1</sup>, Lokesh G<sup>1</sup>, Akshay S A<sup>1</sup>, Dr.Nirmala L<sup>2</sup>

<sup>1</sup>Students, <sup>2</sup>Associate Professor

Department of Mechanical Engineering,

K S Institute of Technology, Bangalore-560109, Karnataka, India

### ABSTRACT

*It is essential to manufacture and develop a novel and innovative type of material for better mechanical and tribological traits from the existing one in the field of materials. Latest methods and developments are focused not only to enhance the properties of materials, also to have combinations of properties. One such material is functionally graded material (FGM) and this is also a candidate that will be providing a solution to forthcoming challenging applications in various sectors. In this research, horizontal centrifugal casting machine is fabricated to develop FGMs as this process is widely used, because of its viable capability and minimum technical requirements, compared to other fabrication processes. Using fabricated machine an Al6061 alloy is developed and tested for its hardness. Hardness is determined in radial direction i.e., from outer to inner. Results depict that the the sample developed at 1000rpm has high hardness at outer layer than the inner layer because of morphological changes.*

*Keywords: FGM (functionally graded material), centrifugal casting, mechanical, tribological*

### 1. INTRODUCTION

Two or more materials are mixed together to produce FGMs to achieve desired properties [1]. Mechanical and Wear resistance of FGM are found to be better than base materials, combining the contradictory properties of base material into single material. FGMs are different from composite materials (Fig. 1) a, in such a way that, composition of composites is homogeneous, whereas, that of FGM (Fig. 1 b.) is non-homogeneous and gradually varies along its length or volume. The gradient composition leads to change in property along the length of material, due to change in the chemical composition and microstructure.

FGMs are classified by gradient of –chemical composition, microstructure or phases, changing from one end to the other [3,4]. Composites are homogeneous mixture and their properties are mixed properties of both materials, which involve a compromise between the desirable properties. FGM contain the unalloyed form of each material and the need for compromise in properties is disregarded. This helps in utilizing the properties of both materials. For illustration, hardness of a ceramic material can be paired with the ductility of metal, without compromising both hardness and ductility. Based on the type of application the properties of engineering components can be successfully fabricated.

FGM are classified based on three categories: firstly based on nature of gradation, FGM can be continuous or step-wise graded structure [7]. In continuous graded structure, as seen in Fig. 2(a), percentage of composition of a material starts from minimum and increases along the length and ends at 100%. Same situation happens for the second material, but in opposite direction along the length. In contrary, step-wise graded FGM has gradation change in steps as shown in Fig. 2(b). Secondly, based on the gradient, three types of FGMs can be fabricated: (i) chemical composition, (ii) porosity (iii) microstructure. In gradient type of chemical composition, the chemical composition varies along its length and volume.

Though there are various processes available for developing FGMs, an cost effective method for production of the bulk FGMs, liquid metallurgy route with centrifugal force method is preferred for the reason that, it is economically feasible and capable to produce large size products. Centrifugal casting is found to be the simplest and cost effective technique for producing large size engineering components,

such as pipes, shafts, bushings. This project aims to fabricate horizontal centrifugal casting machine and also develop Al6061 alloy using fabricated machine

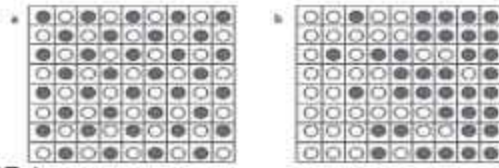

FIGURE 1. (a) Composite material, (b) functionally graded material [2]

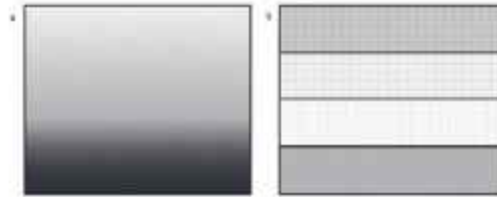

FIGURE 2 (a) Continuous graded FGM, (b) Stepwise FGM gradient materials [8]

## 2. EXPERIMENTAL

### 2.1 MATERIALS

In this project work Aluminium 6061 metal matrix alloy is chosen with density of  $2.7\text{g/cm}^3$  as there is wide scope in structural and engineering applications. horizontal centrifugal casting machine has been used to develop Al 6061 metal matrix alloy. Table 1 show the chemical composition of Al 6061. The die rotational speeds are optimized using empirical analysis considering centrifugal force and gravity force. 1.5 Kg of 6061 alloy was melted in an electrical resistance furnace, at  $780^\circ\text{C}$  the molten metal is poured into the rotating die. A hollow cylinder with length of 100mm, inner radius of 60mm of thickness 15mm was casted as shown in fig 5 (a)

### 2.2 METHODS

Al 6061 alloy is developed using liquid metallurgy route with centrifugal casting process. The following procedure is followed

- Fabrication of centrifugal casting machine

Centrifugal casting equipment includes a cylindrical mould rotated by a motor attached to it as shown in Fig. 4. In this process molten metal is introduced into the die under the gravity force. Gravity force generated due to the rotation of the die, along with the centrifugal force acts on the die. For this reason, die filling is good with effective control of morphology, because of this mechanical properties are enhanced. Based on axis of rotation of die, the casting process can be classified as vertical centrifugal casting process and horizontal centrifugal casting process. In vertical centrifugal casting, the axis of rotation of the die is vertical and is preferred when only small parts in small numbers such as short bushings, sprockets, etc. are to be produced. In horizontal centrifugal casting, the axis of rotation is horizontal and is preferred for producing large components in mass production such as pipes, rolls for steel mills, etc.

A. The basic steps in centrifugal casting process are:

The die is mounted on the prime mover shaft and rotated along a vertical (rpm is reasonable), or horizontal axis.

2. The die is coated with refractory liners for easy removal of solidified component.

3. While rotating molten metal is poured in.

4. The metal that is poured in will then distribute itself over the rotating wall.

5. During cooling lower density impurities will tend to rise towards the centre of rotation.

6. After the part has solidified, it is removed and finished.

The produced workpieces in shape of a hollow cylinders of 60mm and 100mm length with thickness of 15mm. the volume of poured metal is 1500 grams for each casting as shown in fig 5 a.



FIGURE 4. a)Horizontal centrifugal casting machine

TABLE 1. Process parameters used in centrifugal casting

| Process parameters     | Range                    |
|------------------------|--------------------------|
| Pouring Temperature    | 780 <sup>o</sup> c       |
| Mould rotational speed | 600rpm,800rpm & 1000 rpm |

- **Mold Speed of Rotation:**

From literature, to select optimum speed of the mold in horizontal centrifugal casting machine and for the process to work successfully. G factor should be calculated. If the G-factor (GF) is too low in centrifugal casting, the liquid metal will not remain forced against the mold wall during the upper half of the circular path but will "rain" inside the cavity. Slipping occurs between the molten metal and the mold wall, which means that the rotational speed of the metal is less than that of the mold. As per literature values of [GF = 60 to 80] are found to be appropriate for horizontal centrifugal casting.

G-factor GF is the ratio of centrifugal force divided by weight:

Centrifugal force is

$$F = \frac{MV^2}{R}$$

The force of gravity is its weight  $W=mg$ , where  $m$  is the mass in kg, and  $g$  = acceleration of gravity,  $9.8 \text{ m/s}^2$ .

$$GF = CF / \text{Force of gravity}$$

The G-factor at 1000 rpm

Linear Velocity  $V$  of the die can be expressed as:

$$V = \frac{2\pi RN}{60} = (2 * \pi * 0.06 * 1000) / 60 = 6.28 \text{ m/s}$$

Where:  $N$  = rotational speed, rev/min

Gravity Factor

$$GF = \frac{\frac{MV^2}{R}}{Mg} = \frac{V^2}{Rg} = 6.28^2 / (0.06 * 9.8) = 67.003$$

G factor= 67.003,

The Molten metal will remain forced against the mold walls during the circular path with the same G factor. For horizontal centrifugal casting the G factor should be between 60 and 80 for better mechanical properties. so the optimum die speed for better mechanical properties is die speed of 1000 rpm. The process parameters are shown in Table 1

TABLE 2: Chemical Composition of Aluminium 6061 alloy

| Elements | Mn   | Cr   | Fe   | Cu   | Si   | Mg   | Zn  | Ti   | Al      |
|----------|------|------|------|------|------|------|-----|------|---------|
| (wt.%)   | 0.01 | 0.05 | 0.17 | 0.33 | 0.71 | 1.12 | 0.1 | 0.01 | Balance |

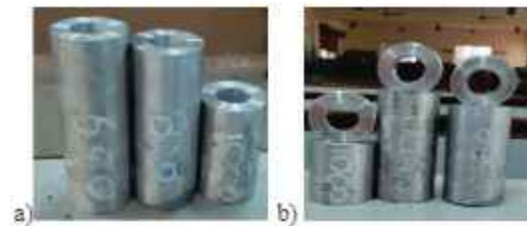

FIGURE 5.a) Casted specimens b) Samples machined from cast

### 2.3 Characterization methods

The following are the experiments carried out on the alloy developed –

- **Micro structural investigation**

Samples were prepared from casted parts (outer, centre and inner) and were ground using emery papers of different grades and diluted alumina solution to achieve scratch free surface. diamond polishing was carried out to attain mirror polished surface. Microstructure analysis was performed to depict the grain size in various layers in order to analyse the effect of pouring temperature, die speed. As shown in fig 4(c)

- **Mechanical properties**

Samples were prepared from the cast (as shown in fig 5b.) and Hardness test was conducted for inner, centre and outer region of casted component using Brinell Hardness Testing machine. The samples were fixed in holder, and ball indenter was subjected to load on the surface. Multiple readings were taken at different positions and average is used for different samples as shown in fig6 The results are tabulated in table 2.

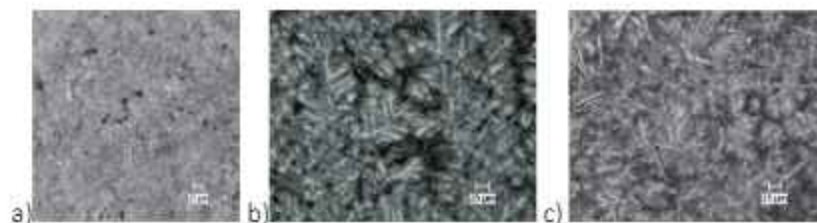

FIGURE 6. Microstructural features of aluminum 6061 alloy (a) (100X) outer(b) middle (100x)(c) (100X)Inner

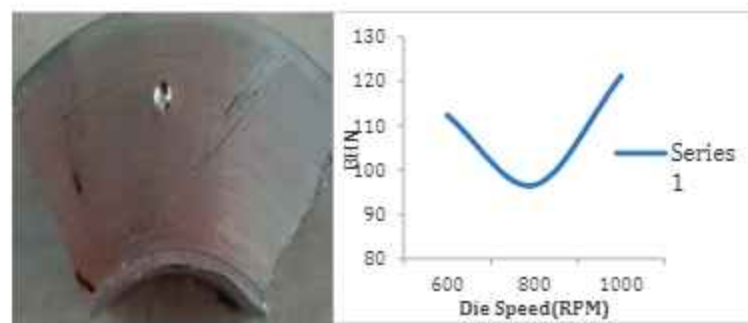

FIGURE 7. Hardness specimen

FIGURE 8. Graph of Die speed vs BH



TABLE 2: Hardness test results

| Sl.No | RPM  | Trail  | Load kg | Dia of ball indenter mm | Dia of Indentation mm | Area of indentation mm <sup>2</sup> | BHN    | Average |
|-------|------|--------|---------|-------------------------|-----------------------|-------------------------------------|--------|---------|
| 1     | 600  | Inner  | 187.5   | 2.5mm                   | 1.5                   | 1.9634                              | 95.49  | 112.26  |
| 2     |      | Center |         |                         | 1.4                   | 1.68                                | 111.60 |         |
| 3     |      | Outer  |         |                         | 1.2                   | 1.43                                | 131.11 |         |
| 4     | 800  | Inner  | 187.5   | 2.5mm                   | 1.6                   | 2.27                                | 82.59  | 96.56   |
| 5     |      | Center |         |                         | 1.5                   | 1.9634                              | 95.49  |         |
| 6     |      | Outer  |         |                         | 1.4                   | 1.68                                | 111.60 |         |
| 7     | 1000 | Inner  | 187.5   | 2.5mm                   | 1.5                   | 1.9634                              | 95.49  | 121.11  |
| 8     |      | Center |         |                         | 1.4                   | 1.68                                | 111.60 |         |
| 9     |      | outer  |         |                         | 1.3                   | 1.20                                | 156.26 |         |

### 3. RESULTS AND DISCUSSION

From literature survey the optical micrographs of centrifugally casted component should have finer grains at outer surface due to rapid solidification and coarser grains on the inner surface due to slower solidification, hence gradient and combination of properties is achieved, if reinforcements are added they spread to the outer periphery in large number and lesser number towards inner surface. The microstructure of

So using centrifugal casting it is economical to produce FGMs than conventional methods. Fig 7 shows the variation of hardness with die speed. The variation of hardness within the casting ie. from inner to outer surface is marginal. The hardness on the inner and middle surface of all the samples tested is 95.49 and 111.60 respectively. The hardness on the outer surface for die speed of 600, 800, and 1000 rpm are 156.26, 111.60 and 131.11 respectively.

The hardness on the outer surface of all the samples is greater than the hardness at inner and centre surfaces. At the outer surface the grains are finer than the grains of centre and inner surfaces, so hardness at the outer surface is higher.

### 4. CONCLUSION

Al 6061 alloy is successfully casted using fabricated horizontal centrifugal casting machine. The experimentation revealed that process of centrifugal casting is very much economical and ease to fabricate functionally graded materials.

Centrifugal casting process is very much economical and ease to fabricate FGMs. The factors to consider are pouring temperature, cooling rate, reinforcement size and speed of rotating mould. The controlling of process variables will help to enhance the properties of the material which is casted. The FGMs produced using this process are finding usefulness in almost all sectors.

From literature the hardness of Al 6061 is 60BHN when produced using conventional methods. But using centrifugal casting the average hardness value of Al6061 is 106.89. so using centrifugal casting process the mechanical properties of Al 6061 can be enhanced

### REFERENCES

- [1] Zhang Zhongtao, Li Tingju, Hongyun Yue, Zhang Jian, Li Jie, Preparation of Al/Si functionally graded materials using ultrasonic separation method, *China Found.* 53 (3) (2008) 194–198.
- [2] Dragan Cukanovic, Aleksandar Radakovic, Dragan Milosavljevic, Gordana Bogdanovic, L.J. Veljovic, Thermal buckling analysis of metal-ceramic functionally graded plate according to high order shear deformation theory, *J. Balkan Tribol. Assoc.* 23 (3) (2017) 413–430.
- [3] C. Jiang Song, Z. Ming Xu, L. Jian-Guo, Fabrication of in Situ Al/Mg<sub>2</sub>Si functionally graded materials by electromagnetic separation method, *Compos. A Appl. Sci. Manuf.* 38 (2) (2007) 427–433.
- [4] S.S. Alieldin, A.E. Alshorbagy, M.A. Shaat, A first-order shear deformation finite element model for

- elastostatic analysis of laminated composite plates and the equivalent functionally graded plates, *Ain Shams Eng. J.* 2 (1) (2011) 53–62.
- [5] A.G. Arsha, E. Jayakumar, T.P.D. Rajan, V. Antony, B.C. Pai, Design and fabrication of functionally graded in-situ aluminium composites for automotive pistons, *Mater. Des.* 88 (2015) 1201–1209.
- [6] Y. Miyamoto, W.A. Kaysser, B.H. Rabin, A. Kawasaki, R.G. Ford, *Functionally Graded Materials: Design, Processing and Applications*, Kluwer Academic Publishers, Boston, 1999.
- [7] R.M. Mahamood, E. Titilayo Akinlabi, Functionally graded materials, *Top. Min. Metall. Mater. Eng.* <https://doi.org/10.1007/978-3-319-53756-6>.
- [8] A. Edwin, V. Anand, K. Prasanna, Sustainable development through functionally graded materials: an overview, *Rasayan J. Chem.* 10 (1) (2017) 149–152.
- [9] R.M. Mahamood, E.T. Akinlabi, Laser-metal deposition of functionally graded Ti6Al4V/TiC, *Mater. Des.* 84 (5) (2015) 402–410.
- [10] R.M. Mahamood, E.T. Akinlabi, M. Shukla, S. Pityana, Functionally graded material: an overview, *Proc. World Cong. Eng.* 3 (2012) 1593–1597.
- [11] R.M. Mahamood, E.T. Akinlabi, Modelling of process parameters influence on degree of porosity in laser-metal deposition process, in: G.C. Yang (Ed.), *Transactions on Engineering Technologies*, Springer, 2015, pp. 31–42.
- [12] X. Miao, D. Sun, Graded/gradient porous biomaterials, *Materials* 3 (1) (2010) 26–47, <https://doi.org/10.3390/ma3010026>.
- [13] M.J. Schneider, The Timken Company, and Madhu S. Chatterjee: Bodycote, Introduction to surface hardening of steels, in: J. Dossett, G.E. Totten (Eds.), *ASM Handbook, Steel Heat Treating Fundamentals and Processes*, 4A, 2013.
- [14] L. Lu, M. Chekroun, O. Abraham, V. Maupin, G. Villain, Mechanical properties estimation of functionally graded materials using surface waves recorded with a laser interferometer, *NDT E Int.* 44 (2) (2011) 169–177.
- [15] S. El-Hadad, H. Sato, E. Miura-Fujiwara, W. Yoshimi, Fabrication of Al-Al<sub>3</sub>Ti/ Ti<sub>3</sub>Al functionally graded materials under a centrifugal force, *Materials* 3 (9) (2010) 4639–4656.
- [16] S.N.S. Jamaludin, F. Mustapha, D.M. Nuruzzaman, S.N. Basri, A review on the fabrication techniques of functionally graded ceramic-metallic materials in advanced composites, *Sci. Res. Essays* 8 (21) (2013) 828–840.
- [17] Gururaj Udupa, S. Shrikantha Rao, K.V. Gangadharan, Functionally graded composite materials: an overview, *Int. Conf. Adv. Manuf. Mater. Eng. Proc. Mater. Sci.* 5 (2014) 1291–1299.
- [18] A. Roey, S. Vasseur, in: *ASM Hand book – Casting*, ASM International, Ohio, 1988, p. 296.
- [19] Y. Watanabe, I.S. Kim, Y. Fukui, Microstructures of functionally graded materials fabricated by centrifugal solid-particle and in-situ methods, *Met. Mater. Int.* 11 (5) (2005) 391–399.
- [20] Minoo Naebe, Kamyar Shirvanimoghaddam, Functionally graded materials: a review of fabrication and properties, *Appl. Mater. Today* 5 (2016) 223–245.



Kammavari Sangham (R) 1952

**K. S. INSTITUTE OF TECHNOLOGY**

(Affiliated to VTU, Belagavi & Approved by AICTE, New Delhi, Accredited by NAAC & NBA)

#14, Raghuvanahalli, Kanakapura Main Road, Bengaluru-560109

Tel : 28435722 / 724E-mail : principal@ksit.edu.in Web : www.ksit.edu.in

DEPARTMENT OF MECHANICAL ENGINEERING  
PROCEEDING NCRIE - 2022  
KSIT

**National Conference  
on  
RECENT INNOVATIONS IN  
ENGINEERING - 2022**

**JUNE 23rd - 24th, 2022**

**NCRIE - 2022**

Organized by

**DEPARTMENT OF MECHANICAL  
ENGINEERING  
In Association With**



ISBN : 978-81-929425-2-0

PROCEEDINGS

**NCRIE -2022**

**National Conference on Recent  
Innovations in Engineering- 2022**

23<sup>rd</sup> - 24<sup>th</sup> June 2022

Bengaluru, Karnataka, India



*Organized by*

**DEPARTMENT OF MECHANICAL ENGINEERING**

**in association with**



# **K.S. INSTITUTE OF TECHNOLOGY**

## **VISION OF THE INSTITUTION:**

To impart quality technical education with ethical values, employable skills and research to achieve excellence”.

## **MISSION OF THE INSTITUTION:**

- To attract and retain highly qualified, experienced and committed Faculty.
- To create relevant infrastructure.
- Network with industry and premier institutions to encourage emergence of new ideas by providing Research and Development Facilities to achieve excellence.
- To inculcate the professional and ethical values among young students with employable skills and knowledge acquired in transforming society

## Management Message



**Sri. R. Rajagopal Naidu**  
President



**Sri. R. Leela Shankar Rao**  
Hon. Secretary



**Sri. T. Neerajakshulu Naidu**  
Treasurer

It is matter of great pride that, KSIT as a premier institution imparting technical education is adopting innovative practices in creating an environment that fosters the achievement of academic excellence and the pursuit of research activity. NCRIE-2022 organized by Department of Mechanical Engineering is a part of this initiative that will provide a platform for researchers, academicians and practicing professionals to discuss and deliberate on the latest technologies and trends in engineering.

We extend our warm greetings and best wishes for the success of the conference.

## Management Committee



### *Sitting From Left to Right:*

**Sri. T. Neerajakshulu (Treasurer), Sri. S. Venugopal Naidu (Joint Secretary), Sri. B. Lokanadha Naidu (Vice President), Sri. R. Rajagopal Naidu (President), Dr. M. Rukmangada Naidu (Vice President), Sri. R. Leela Shankar Rao (Hon. Secretary), Sri. V. Rajendra Naidu (Joint Secretary), Sri. M. Yogamurthy (Internal Auditor)**

### *Standing From Left to Right:*

**Sri. V. Ramesh Kumar (Director), Sri. J.M.Chandra Shekar (Director), Sri. G. V. Ramesh (Director), Sri. T. N. Manjunath (Chairman, Environment Committee), Sri. D. Jagadish Kumar (Chairman, Transport Committee), Sri. N. Krishnama Naidu (Chairman, Hostel Committee), Sri. A. V. Nagaraj (Chairman, Building Committee), Sri. N. M. Krishnamurthy (Chairman, Finance Committee), Sri. G. Ramana Babu (Director), Sri. M. Sudhakar (Chairman, Legal cell), Sri. P. Prabhakar Naidu (Director).**

## Vice Chancellor's Message



I am glad to know that the Mechanical Engineering department of K.S Institute of technology is organizing National Conference on Recent Innovations in Engineering on 23<sup>rd</sup> and 24<sup>th</sup> June 2022.

I wish the Conference will attract researchers, industry professional's academicians and students to deliberate on recent innovative research ideas, research applications and long-term solutions in various fields of Mechanical Engineering, address the challenges faced by the society and come out with new ideas

My best wishes to the organizers of NCRIE-2022 and the editorial team which is bringing out the proceedings of the said National Conference and I wish the proceedings to be the rich source of knowledge on recent innovation in Engineering and Technology



**Dr. Karisiddappa**  
Vice Chancellor 20.6.22

**Dr Karisiddappa**  
**Vice Chancellor,VTU**

## CEO's message



A progressive institution imparting technical education should be always vibrant and keep pace with the happenings throughout the world. This can only happen when there is a strong zeal to continuously learn on the part of both teachers and the taught. In order to encourage and promote continuous learning attending or organizing a National Conference is one of the ways.

I am very glad that K.S. Institute of Technology is organizing “**National Conference on Recent Innovations in Engineering- 2022**” on the 23<sup>rd</sup> & 24<sup>th</sup> June 2022. I wish all the participants as well as Research Scholars a great deal of knowledge sharing and learning. I also wish all the organizers a good success in conducting this two-day event.

## Principal's Message



The recent trends in mechanical engineering have redefined the whole domain of Mechanical. The most recent innovations, trends, practical changes encountered and the solutions adopted in the field of Mechanical Engineering to cater for the need of the ever growing technological world. It is heartening to note that the Department of Mechanical engineering, KSIT, Bangalore is organizing the National Conference on Recent Innovations in Engineering. This is a prestigious event for the Institute that will provide exposure to innovative technologies and will be a valuable learning experience for the delegates. My best wishes to the organizers of the conference and all the participants.

**Dr. Dilip Kumar K.**  
**Principal & Director**



## Convener & HOD's Message



In Mechanical department, we work with the theme of imparting quality education by exposing our students to recent innovations & developments in various fields in mechanical engineering through Conference, Workshops and Technical talk. The outcome of our vision to achieve best is this National Conference on Recent Innovations in Engineering. The main goal of NCRIE-2022 is to create a platform for the research scholars, staff & students to share their knowledge and expertise in various domains. This conference aims at triggering innovative ideas among audiences through quality papers presented by scholars.

I would like to thank our Management & Principal for providing this opportunity. I would like to thank Advisory committee, Review committee, ME Conference coordinators & organizing committee members for their hard work in making this conference a reality. I would like to thank teaching & supporting staff of ME dept. I hope that NCRIE-2022 will be grand successes & hope to organize many such events in future.

**Dr. M.Umashankar**  
**Professor and Head**  
**Dept. of Mechanical Engg.**

## **Chief Patrons**

**Sri R. Rajagopal Naidu**

President, Kammavari Sangham

**Sri R. Leela Shankar Rao**

Hon.Secretary, Kammavari Sangham

**Sri T. Neerajakshulu Naidu**

Treasurer, Kammavari Sangham

## **Patrons**

**Dr. Karisiddappa** Vice Chancellor VTU

**Dr. A.S. Deshpande** Registrar VTU

**Dr. B. E. Rangaswamy** Registrar (Evaluation) VTU

## **Academic Advisory Board**

**Dr. H.P Khincha**

Chairman & Former Vice Chancellor VTU and Professor IISc

**Dr. K.N.B. Murthy**

Member & Vice Chancellor of DSU University

**Dr. Y. N. Srikanth**

Member, Prof. IISc

**Dr. Shyam Vasudeva Rao**

Member, Industrialist

**Dr. K.V.A. Balaji**

CEO, KSGI

## **Conference Chair**

**Dr. Dilip Kumar K.**

*Principal & Director*

## **Convener**

**Dr. M. Umashankar**

*Prof. & Head*

## **Coordinators**

**Dr. L. Nirmala**

*Associate Professor*

**Dr. Nagaprasad K S**

*Associate Professor*

## **Organizing Committee**

**Prof. Nagabhushana M,** *Associate Professor*

**Prof. K. Prasad,** *Associate Professor*

**Dr. Girish T. R,** *Associate Professor*

**Prof. Manjunath B. R,** *Assistant Professor*

**Prof. Ranganath N,** *Assistant Professor*

**Prof. Anilkumar A,** *Assistant Professor*

**Prof. Harish U,** *Assistant Professor*

**Prof. Parashuram A. K,** *Assistant Professor*

**Prof. Tejaswini M. L,** *Assistant Professor*

**Dr. Saleem Khan,** *Assistant Professor*

**Prof. Rajesh G. L,** *Assistant Professor*

## Advisory and Technical Committee

**Dr. Gopalakrishna K**

Principal, Jyothy Institute of Technology, Bangalore.

**Dr. Rama Narasimha K**

Principal, K. S. School of Engineering & Management, Bangalore.

**Dr. Chennakshesvalu K**

Principal, East West Institute of Technology, Bangalore.

**Dr. Vijaya Simha Reddy B. G**

Principal, Vemana Institute of Technology, Bangalore.

**Dr. Seenappa**

Principal, Government Engineering College, Kushalnagar.

**Dr. Thirumaleshwara Bhat,**

Principal, Shri Madhwa Vadiraja Institute of Technology and Management, Bantakal, Udupi.

**Dr. Vasu M**

Associate Professor, NIT, Thiruchy, TN.

**Mr. Seshnath B**

CEO & MD, Walvoil Fluid Power India Pvt Ltd, Bangalore.

**Dr. RamaMohan Y. S**

Professor & Head, Aerospace Engg, BMSCE, Bangalore.

**Dr. Annamali K**

Professor, Vellore Institute of Technology, Chennai.

**Dr. Abdul Sharief**

Professor & Dean, Presidency University.

**Dr. Chikkanna N**

Professor, VTU Center for PG Studies, Muddenahalli.

**Dr. Balaji B**

Professor & Head, MED, KSSEM, Bangalore.

**Dr. Mahamani A**

Dean, R&D, Vemu Institute of Technology, AP.

**Dr. Vijay G S**

Professor, Manipal Institute of Technology.

**Dr. Swamy D R**

Professor, JSSATE, Bangalore.

**Dr. Ravikumar D. V**

Associate Professor, MED, GATE, Bangalore.

**Dr. Pradeep, Badigere**

Associate Professor, MED, NMIT, Bangalore.

**Dr. Mahadev Nagaral**

Deputy Manager(Design)HAL, Bangalore.

## Review Committee

**Dr. Rama Narasimha K**

Principal, K. S. School of Engineering & Management, Bangalore

**Dr. Seenappa**

Principal, Government Engineering College, Kushalnagar

**Dr. Mahamani A**

Dean, R&D, Vemu Institute of Technology, AP

## **DEPARTMENT OF MECHANICAL ENGINEERING**

### **VISION OF THE DEPARTMENT :**

To groom incumbents to compete with their professional peers in mechanical engineering that brings recognition

### **MISSION OF THE DEPARTMENT:**

- To impart sound fundamentals in mechanical engineering
- To expose students to new frontiers
- To achieve engineering excellence through experiential learning and team work.

## INDEX

| Sl. No | Paper Id | Title   | Page Number |
|--------|----------|---|-------------|
| 1      | ME - 01  | TENSILE TESTING OF E-GLASS FIBER/ PLA MATRIX DEVELOPED BY USING 3-D PRINTING TECHNIQUE  | 1 - 6       |
| 2      | ME-02    | PRODUCTION AND OPTIMIZATION FOR PERFORMANCE PARAMETERS OF A DIESEL ENGINE RUNNING ON SIMAROUBA BIODIESEL BLENDED WITH SIMAROUBA OIL | 7-15        |
| 3      | ME-03    | FABRICATION OF REMOTE-CONTROL MOTORIZED SCREW JACK  | 16-20       |
| 4      | ME-04    | DESIGN AND ANALYSIS OF DISHED ENDS  | 21-25       |
| 5      | ME-05    | ENVIRONMENTAL IMPACTS AND EMISSION GUIDELINES ON HYBRID VEHICLES  | 26-28       |
| 6      | ME-06    | IMPLEMENTATION AND EFFECTIVENESS OF SOLAR-WIND HYBRID CHARGING STATION FOR ELECTRIC VEHICLES  | 29-31       |
| 7      | ME-07    | OVERVIEW OF SOLAR POWER SYSTEMS   | 32-34       |
| 8      | ME-08    | FIBER REINFORCED COMPOSITES- A REVIEW   | 35-40       |
| 9      | ME-09    | FABRICATION OF SONAR GLASSES FOR VISUALLY IMPAIRED  | 41-44       |
| 10     | ME-10    | DESIGN AND FABRICATION OF FINGER MILLET CUTTING MACHINE- A REVIEW   | 45-47       |
| 11     | ME-11    | SOLAR POWERED AQUAPONICS SYSTEM   | 48-51       |
| 12     | ME-12    | POWER ASSISTED POULTRY GARBAGE CHIPPING MACHINE   | 52-58       |
| 13     | ME-13    | DESIGN AND FABRICATION OF A SEMI-AUTOMATIC PNEUMATIC INJECTION MOLDING MACHINE  | 59-62       |
| 14     | ME-14    | EXPERIMENTAL & NUMERICAL INVESTIGATION ON VIBRO-ACOUSTIC BEHAVIOUR OF THIN CYLINDRICAL SHELL  | 63-67       |
| 15     | ME-15    | EFFECT OF COMBINATION OF ETHANOL INJECTION AND AFTER TREATMENT DEVICES ON DIESEL ENGINE EMISSION- A REVIEW                          | 68-70       |
| 16     | ME-16    | EXPERIMENTAL STUDIES ON OSCILLATING HEAT PIPE USING NANO FLUIDS   | 71-76       |
| 17     | ME-17    | DESIGN AND FABRICATION OF GYM EQUIPMENT FOR POWER GENERATION  | 77-80       |
| 18     | ME-18    | DESIGN AND FABRICATION OF MIST IRRIGATION SYSTEM  | 81-84       |
| 19     | ME-19    | EFFECT OF COMBINATION OF METHANOL INJECTION AND AFTER TREATMENT DEVICES ON DIESEL ENGINE EMISSION- A REVIEW                         | 85-86       |

|    |       |   |         |
|----|-------|---|---------|
| 20 | ME-20 | DESIGN AND DEVELOPMENT OF DUAL LUG NUT FOR TIGHTENING AND LOOSENING OF FOUR WHEELER TYRES | 87-90   |
| 21 | ME-21 | LOW COST MECHANICAL FLOOR CLEANING MACHINE- A REVIEW                                      | 91-97   |
| 22 | ME-22 | DESIGN AND FABRICATION OF LOW COST MECHANICAL VENTILATOR                                  | 98-103  |
| 23 | ME-23 | DESIGN AND FABRICATION OF SEMI-AUTOMATED MACHINE VICE                                     | 104-109 |
| 24 | ME-24 | DESIGN AND FABRICATION OF SOIL MOISTURE SENSING ROBOT                                     | 110-113 |
| 25 | ME-25 | REVIEW ON THE DEVELOPMENT OF ALUMINIUM ALLOY (6061) REINFORCED WITH ZrO <sub>2</sub>      | 114-114 |
| 26 | ME-26 | DESIGN AND FABRICATION OF AIR BRAKE SYSTEM USING IC ENGINE EXHAUST GAS                    | 115-118 |

## TENSILE TESTING OF E-GLASS FIBER/ PLA MATRIX DEVELOPED BY USING 3-D PRINTING TECHNIQUE

Karthik R , Aishwarya K S , Nayaz Shareef , Gnanesh P M, Amith Kumar S J

Department of Mechanical Engineering  
J N N College of Engineering, Shivamogga, Karnataka, India

### ABSTRACT

*Composite materials play a vital role in a wide range of applications. Their adaptability to different situations and desirable properties attracted many industries. In the automotive industry the demand for lighter weight components is increasing day by day. glass-fiber reinforced PLA matrix composites are making inroads used in the automotive industry because of their superior properties such as high specific strength and stiffness. In this study glass fiber reinforced composites were manufactured using PLA matrix. To improve toughness of glass fiber reinforced PLA matrix, inorganic fillers dopped. The novel 3d printing technique is used for the development of composite material experimentation were conducted as per AST standards. Result of experimentations reveals that glass fiber reinforced pla matrix dopped with inorganic fillers exhibited high specific properties and good toughness.*

**Keywords:** Glass fiber, polymer composite, mechanical property, thermal behaviour, vibrational behaviour, water absorption.

### 1. INTRODUCTION

Composites are heterogeneous materials made up of two or more components, fillers or reinforcing fibres, and a compactable matrix. The matrix could be made of metal, ceramic, or polymer. It provides the shape, surface appearance, environmental tolerance, and overall longevity of the composites, while the fibre reinforcement carries the majority of the structural load, providing macroscopic stiffness and strength. Because it combines the most desirable features of its elements while suppressing their least desirable properties, a composite material can deliver superior and unique mechanical and physical capabilities.

Fibreglass reinforced plastic (FRP), sometimes known as fibreglass, is a thermoset plastic resin containing glass fibre reinforcement. There are two types of plastic resins: thermosets and thermoplastics. Chemical, electrical, and thermal properties are determined by the plastic resin system. Fibre gives dimensional stability, heat resistance, and strength. Color and surface finish are determined by additives, which also influence weathering and flame retardancy. Chemical reactions are involved in the processing of FRP composites. Many factors influence the final qualities, including the kind, amount, and composition of resin systems and reinforcements. Furthermore, the inclusion of an additive can have a significant impact on the characteristics of a FRP composite. Benefits and Features of composite materials are corrosion resistance, high strength, light weight, dimension stability, parts consolidation and tooling minimisations, minimum finishing required, low moderate tooling cost, design flexibility.

### 2. MATERIALS AND METHODS

Glass fibers are one of the most adaptable industrial materials currently available. They come in practically limitless quantities. 3 Silica is present in all glass made from compounds. They have desired bulk qualities such as hardness, transparency, chemical resistance, stability, and inertness, as well as fibre properties such as strength, flexibility, and stiffness. 4 Glass fibres are used to make structural composites, printed circuit boards, and a variety of other specialty products.

Glass fibre is a material made up of several fine fibres of glass. The product is one of the most versatile industrial materials known today. It has comparable mechanical properties to other fibres such as carbon fibre and polymers. Glass fibre is used as a reinforcing agent for many polymer products in order to form a very durable and lightweight material, known as fibreglass. Fibreglass offers some unique advantages over other materials due to



its thickness, weight and strength. With such a wide range of properties, the material can satisfy design and project objectives in many industrial applications. Properties of glass fibre

**High tensile strength.** Glass has greater tensile strength than steel wire of the same diameter, at a lower weight.

**Dimensional stability.** Glass fibre is not sensitive to variations in temperature and hygrometry. It has a low coefficient of linear expansion.

**High heat resistance.** Glass fabrics retain 50% of room temperature tensile strength at 370°C, 25% at 480°C, a softening point of 845°C and a melting point of 1,135°C.

**Good thermal conductivity.** Glass fibres are great thermal insulators because of their high ratio of surface area to weight. This property makes it highly useful in the building industry.

**Great fire resistance.** Since glass fibre is a mineral material, it is naturally incombustible. It does not propagate or support a flame. It does not emit smoke or toxic products when exposed to heat.

**Good chemical resistance.** Glass fibre is highly resistant to the attack by most chemicals.

**Outstanding electrical properties.** Glass fibre has a high dielectric strength and low dielectric constant. It is a great electrical insulator even at low thickness.

**Dielectric permeability.** This property of glass fibre makes it suitable for electromagnetic windows.

**Compatibility with organic matrices.** Glass fibre can vary in sizes and has the ability to combine with many synthetic resins and certain mineral matrices like cement.

**Great durability.** Glass fibre is not prone to sunlight, fungi or bacteria.

**Non-rotting.** Glass fibre does not rot and remains unaffected by the action of rodents and insects.

**Highly economical.** It is a cost-efficient choice compared to similar materials.



FIGURE 1: Glass Composition by Weight

| Composition              | E-glass   |
|--------------------------|-----------|
| Silicon Dioxide          | 52 – 62%  |
| Calcium Oxide            | 16 – 25 % |
| Aluminium Oxide          | 12 – 16%  |
| Boron Oxide              | 8 – 13 %  |
| Sodium & Potassium Oxide | 0 – 1 %   |
| Magnesium Oxide          | 0 – 6 %   |

TABLE 1: Mechanical Properties of Fibers

| Fibers    | Density | Tensile Strength<br>Mpa | Tensile Modulus(<br>Young's moduls)<br>Mpa | Ultimate<br>Elongation<br>Mpa |
|-----------|---------|-------------------------|--|-------------------------------|
| E - glass | 0.094   | 3500                    | $6 \times 10^3$                            | 3447                          |

## 2.1 PLA matrix

Researchers have been focusing on the creation of biodegradable polymers since the early 1970s, as a response of growing concern about material resources and plastic disposal difficulties. Composite materials are made up of multiple components combined into a single structure. Solid and stiff fibres with a low density are used in the majority of composites. Polylactic acid (PLA) is a flexible polymer created from sustainable agricultural waste that is fermented into a carboxylic acid. For product modification, the lactic acid is polymerized using a cyclic dilactone, lactide, and ring. Companies have been encouraged to manufacture environmentally friendly products by a growing awareness of environmental sustainability and new regulations and rules. A lot of studies are performed that aim to produce entirely biodegradable composite structures with PLA and natural fibres combination. Since both PLA and natural fibres are sourced from renewable sources, biodegradable, as well as biocompostable, natural/PLA composites are recyclable green materials. Thus, the biocomposites have significant advantages due to their reduced manufacturing and waste disposal treatment costs, as natural fibre reinforced composites can be disposed of easily via landfill, incineration, or by green treatment of pyrolysis, as stated by Harussani et al. . In addition, biopolymers are suitably utilised in various methods of composite fabrication, for example, injection moulding, extrusion, compression moulding, and so forth, whereas less research had been conducted on composites derived from recycled raw materials with matrixes. Biopolymers also satisfy the long-term characteristics of sustainable materials because they are not single-use products. The investigation by Oksman et al. showed that the strength indicated by the stiffness of glass fibre composites was lower than the natural fibre composites. Moreover, the adhesion of the fibre/matrix is a dynamic process with several overlapping variables. Graupner believed that lignin has the ability to strengthen the fibre and matrix bond that is proven by the production of new advanced types of natural fibre reinforced PLA composite.



## 2.2 3D printing technique

The production of a three-dimensional object from a CAD model or a digital 3D model is known as 3D printing or additive manufacturing. The term "3D printing" can apply to a range of procedures in which material is deposited, connected, or solidified under computer control to make a three-dimensional object, with material added layer by layer (such as polymers, liquids, or powder grains).

In the 1980s, 3D printing processes were thought to be only suited for producing functional or aesthetic prototypes, and fast prototyping was a more relevant phrase at the time. As of 2019, 3D printing's precision, repeatability, and material range have improved to the point where some 3D printing techniques are viable as an industrial-production technology, and the phrase additive manufacturing can be used interchangeably with 3D printing. One of the main benefits of 3D printing is the capacity to create extremely complicated shapes or geometries that would be hard to create by hand, such as hollow pieces or items with internal truss structures to minimise weight. Fused deposition modelling (FDM) is a technique that employs a continuous thermoplastic filament.

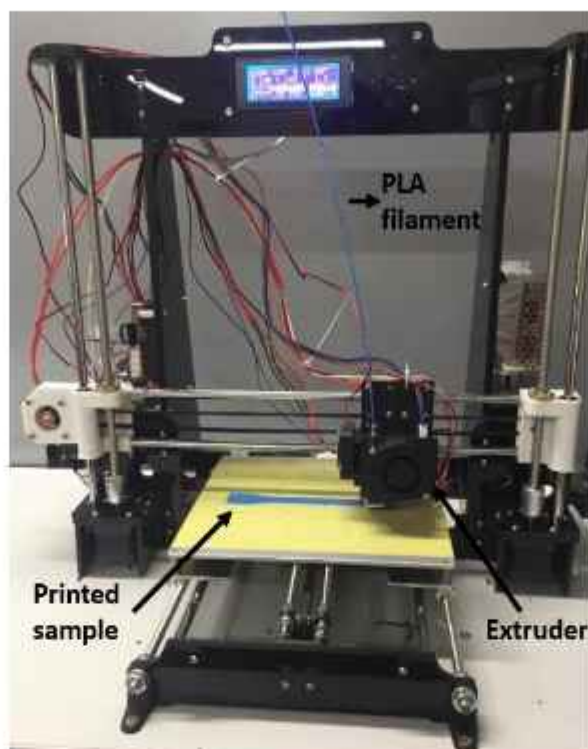

### 3. EXPERIMENTATION

Tensile testing, often known as tension testing, is a basic materials science and engineering test that involves applying a controlled tension to a sample until it fails. Ultimate tensile strength, breaking strength, maximum elongation, and reduction in area are all directly determined using a tensile test. The Young's modulus, Poisson's ratio, yield strength, and strain-hardening characteristics may all be calculated using these measurements. The most popular method for determining the mechanical properties of isotropic materials is uniaxial tensile testing. Biaxial tensile testing is used on some materials. The way load is given to the materials is the fundamental variation between these testing devices.

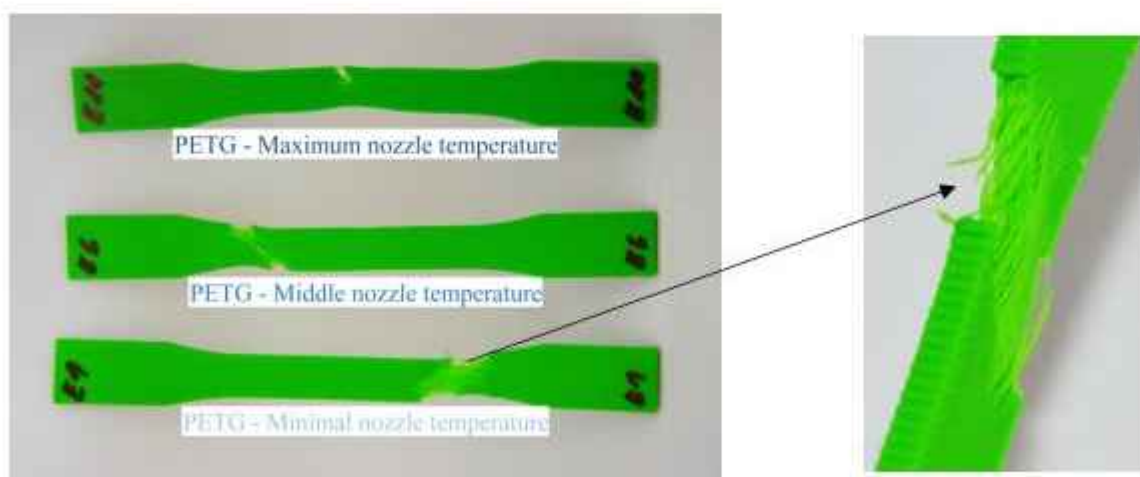

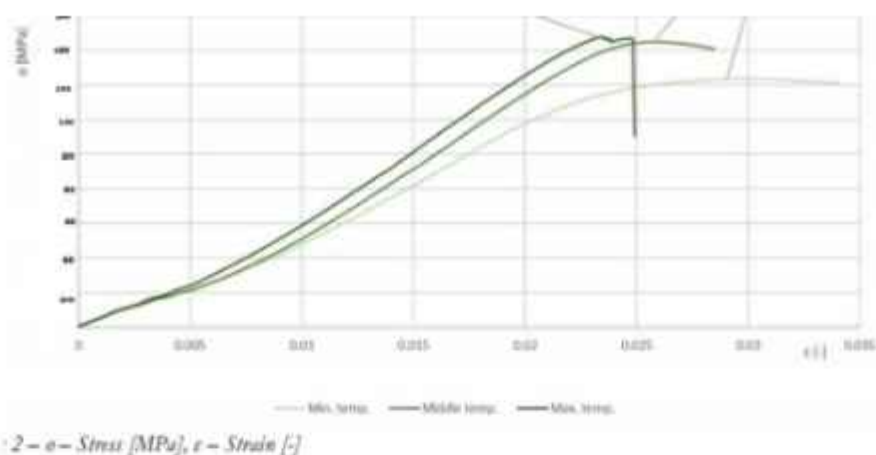

FIGURE 2: Tensile diagram

#### 4. CONCLUSION

The outcome of the experimental reveals that 3 -D printing technique is the best technique to develop good quality composite materials

\*Glass/ PLA composite developed by 3D printing technique exhibited good tensile strength in a range of 140 - 170 Mpa.

\*This glass/ PLA composite can be used in automobile and aero space application because of its excellent tensile properties

#### REFERENCES

- [1] HAUSMAN, K., HORNE, R. (2014). 3D printing for dummies. 2nd ed., New Jersey: John Wiley & Sons, Inc.
- [2] HLUCHÝ, M., KOLOUCH, J. (2007). Strojírenská technologie 1: Nauka o materiálu. 4th ed., Praha: Scientia.
- [3] DVORAK, K., ZARYBNICKA, L., DVORAKOVA, J. (2019). Quality Parameters of 3D print Products by the DMLS Method. Manufacturing Technology, Vol. 19, No. 2, 2019, p. 209-215.
- [4] RAZ, K. (2019). Advantages of Additive Technologies Usage in Design of Cooling Channels. Manufacturing Technology, Vol. 19, No. 1, 2019, p. 135-138.
- [5] KLOSKI, W.L., KLOSKI, N. (2017). Začínáme s 3D tiskem. 1st ed., Brno: Computer Press.
- [6] KROTKÝ, J., HONZÍKOVÁ, J., MOC, P. (2016). Deformation of Print PLA Material Depending on the Temperature of Reheating Printing Pad. Manufacturing Technology, Vol. 19, No. 1, 2019, p. 23-28.
- [7] SVOBODA, P., BRANDEJS, J. (2013). Výběry z norem pro konstrukční cvičení. 5th ed., Brno: Cerm.
- [8] STRÍTECKÝ, J., PRŮŠA, J., BACH, M. (2019). Základy 3D tisku s Josefem Průšou [online]. Praha: Prusa Research s.r.o. Available at: <http://www.prusa3d.cz/kniha-zaklady-3d-tisku-josefa-prusi>. [2019-08-29].
- [9] JOHANSSON, F. (2016). Optimizing Fused Filament Fabrication 3D printing for durability. Master's thesis, Blekinge Institute of Technology.
- [10] McCORMIC, N., LORD, J. (2010). Digital Image Correlation. Materials Today, Vol. 13, No. 12, 2010, p. 52-54.

[11] QIONG, L., YOURONG, Y., LEILEI, C. (2016). Computer Visual Measurement Technology and Algorithm Simulation for the Assembly of Large Aircraft Parts. *Manufacturing Technology*, Vol. 16, No. 3, 2016, p. 538-543.

[12] SRINIVASSAN, R., RUBAN, W., DEEPANRAJ, A., BHUVANESH, R., BHUVANESH, T. (2020). Effect on infill density on mechanical properties of PETG part fabricated by fused deposition modelling. *Materials today proceedings*, Vol. 27, Part 2, 2020, p. 1838-1842.

[13] STRATASYS (2018). Spec Sheet [online]. Eden Prairie: Stratasys Ltd. Available at: <https://www.stratasys.com/materials/search/pla>. [2021-01-13].

[14] STRATASYS (2018). Spec Sheet [online]. Eden Prairie: Stratasys Ltd. Available at: <https://www.stratasys.com/materials/search/abs-m30>. [2021-01-13].

#### **CORRESPONDING AUTHOR**

**KARTHIK R**

Department of Mechanical Engineering

J N N College of Engineering, Shivamogga, Karnataka, India

577201

Email : [karthikrsmg02@gmail.com](mailto:karthikrsmg02@gmail.com)

Mobile: 8217642623

## PRODUCTION AND OPTIMIZATION FOR PERFORMANCE PARAMETERS OF A DIESEL ENGINE RUNNING ON SIMAROUBA BIODIESEL BLENDED WITH SIMAROUBA OIL

Ghaleppa B\*, Rana Pratap Reddy N, Sanjay M Patil, Rohit Bhat H, Nikhil V Hoskoti, Thilak Gowda A

\*Assistant Professor, Dept. of ME., Global Academy of Technology, Bengaluru – 560098

Ph: +91-9886439872, Email: [ghaleppahaldoddi@gmail.com](mailto:ghaleppahaldoddi@gmail.com)

### ABSTRACT

*Engine fuel economy is gaining day by day and will continue to increase. However, as the number of vehicles increases, the gasoline demand grows with it. In the upcoming days, fossil fuels will be scarce and costly. Alternative fuels technology will become more prominent in the coming months as a result of strong demand and depletion of fossil fuels. The primary drivers of alternative fuels are sustainable development and environmental preservation. The Simarouba oil source was chosen as it is non-edible, non-toxic, and biodegradable, and it is widely available throughout India. The samples are a mix of Simarouba Oil (SO) and its biodiesel (SOME). The Simarouba biodiesel was produced using an acid and base transesterification method. The properties were determined and compared with diesel. This study aimed to run the performance characteristics test and to tabulate them along with optimizing them using Taguchi, Linear Regression and ANOVA methods.*

**Keywords:** Simarouba Oil, Transesterification, Simarouba Oil Methyl Ester (biodiesel), BP, BTE, BSFC, Optimization, Taguchi analysis.

### NOMENCLATURE

Simarouba Oil (SO), Free Fatty Acids (FFA), Brake Power (BP), Brake Thermal Efficiency (BTE), Brake Specific Fuel Consumption (BSFC), Signal-to-Noise ratio (SN ratio), Analysis of Variance (ANOVA), SB70 (Simarouba Biodiesel 70% + SO 30%), Simarouba Biodiesel 100% (SB100).

### 1. INTRODUCTION

Many environmental and economic concerns have arisen as a result of the increased use of fossil fuels. There has been a growing interest in achieving great power with higher fuel efficiency and lower maintenance costs over the years. Manufacturers are constantly developing the CI engine to satisfy the above-mentioned objectives, considering these challenges. To maintain a sustainable environment, they should also consider lowering exhaust and emissions. Biodiesel is the best suitable alternative fuel that fits all of the above-mentioned parameters, considering all of these aims.

High viscosity and cloud points of raw Simarouba oil in the CI engine are determined as non-compatible and hence the need for transesterification was determined [1]. Simarouba biodiesel was obtained from crude Simarouba oil using a two-step esterification process, with a yield of 91.4 % and adequate quality [2]. The alkaline catalyzed esterification can be carried out using NaOH and KOH which resulted in the production of Simarouba biodiesel with good yield and good fuel quality [3]. Simarouba biodiesel and its blends with diesel were found to have qualities similar to diesel, and the CI engine performed well during testing. The performance characteristics such as BP, BSFC, and BTE were almost equal to that of diesel at certain compression ratios. The emission parameters such as HC and CO showed fewer intensities whereas NOx was found to be large compared to diesel emissions [4]. Taguchi analysis was used to optimize engine operating parameters in order to improve performance and reduce emission characteristics. The optimum operating parameters for an L16 orthogonal array were determined to be 20% fuel fraction, 18:1 compression ratio, 270 bar injection pressure, and 25 injection timing, with results of 27.17 % BTE, 17.82 ppm HC, and 2.5044 % vol. CO<sub>2</sub>. [5]. The preheat S20 simarouba biodiesel blend can be used in diesel engine without any modifications and in which gives 10% lesser BSFC than diesel fuel [6]. The taguchi method was applied in performance parametric of a diesel engine. The CR has the greatest impact on the BSFC, with CO exhaust emissions being determined by load. 0.225 kg/kWh, CO (0.24 %), and smoke capacity were the perfect conditions for BSFC responses (47.25 ppm) [7]. The sample was suitable for diesel engine without any alternations in engine for better perform and emission at a compression ratio of 17 and engine load 80% [8]. Jatropha, Karanja and their blends with diesel were tested on a diesel engine and their combustion and emission values were analyzed. Diesel, Jatropha, and Karanja have thermal efficiency of 29.8 %, 29 %, and 28.6 % at higher loads, respectively. In the performance patterns it was observed that presence of vegetable oil resulted in an elongated and delayed burning period. The performance and emission characteristics of blended biofuels were closer to diesel readings [9]. On a

diesel engine, preheated crude palm oil, palm oil methyl ester, and their blends were tested for engine performance and exhaust emissions and compared to diesel values. Palm oil methyl ester and its blends had greater BTE than warmed crude palm oil in the majority of load circumstances, but far less than diesel. The presence of extra oxygen resulted in a lower rate of generation of HC and CO than diesel. When crude palm oil was heated, it produced more NO<sub>x</sub> than other fuels [10]. Usage of lubrication engine oil and conversion into biodiesel for which the emission and performance readings were determined and concluded with readily using in engine without any modifications [11].

All other related works in this field involve the blending of diesel with biodiesel whereas, this work focus on eliminating the usage of diesel and using Simarouba oil blend with Simarouba biodiesel. The engine parameters are then optimized for the production of desirable performance parameters.

## 2. EXPERIMENTAL METHODS

### 2.1 Extraction and FFA determination

The raw Simarouba Oil (SO) is extracted, filtered (using Whatman filter paper), and preheated at about 110°C to remove water moisture and impurities if any. The SO is then checked for FFA which was determined to be 2.57%.

### 2.2 Two – step Transesterification

The preheated SO is treated for esterification reaction. A 1000 ml of Simarouba oil is taken into a 3-neck flask which is placed on a magnetic stirrer with a magnetic pellet inside it. The reaction was maintained at a temperature and speed of 60°C and 600-800 RPM respectively. 300 ml of methanol and 6g of NaOH (3.5g+FFA) is stirred at 63°C, mixed with oil in a 3-neck flask, and placed on a stirrer. The solution is maintained at 60-63°C and 600 RPM for 2 hours. The mixture was allowed to separate for about 2 hours. The biodiesel is transferred to the reaction vessel and stilled for 1000 RPM at 70°C. The methanol condensate is evaporated which is collected and measured. The biodiesel is then water washed twice by mixing with warm water vigorously and allowed to separate for about 1 hour and the water wash process is repeated until the pH value of drained water reaches 7pH. The biodiesel is then heated to about 100°C under suitable stirring and left to cool gradually.

### 2.3 Fuel samples preparation

Test fuels were prepared based on a volumetric basis such as SB100 (100% SB+0% SO), SB90 (90% SB+10% SO), SB80 (80% SB+20% SO), SB70 (70% SB+30% SO). The above samples' properties were determined and compared to diesel, with the test results shown in TABLE 1.

TABLE 1: Properties of test fuels

| Properties                              | Diesel | SB100 | SB90  | SB80 | SB70 | SO    |
|---|--------|-------|-------|------|------|-------|
| Kinematic Viscosity (m <sup>2</sup> /s) | 4.09   | 5.59  | 6.78  | 8.55 | 9.11 | 36.6  |
| Density (kg/m <sup>3</sup> )            | 842    | 856   | 852   | 856  | 855  | 858   |
| Flash Point (°C)                        | 55     | 160   | 162   | 164  | 174  | 218   |
| Fire point (°C)                         | 65     | 172   | 178   | 178  | 182  | 246   |
| Calorific Value (MJ/kg)                 | 44.5   | 42.64 | 42.01 | 40.8 | 40.6 | 37.62 |

## 3. ENGINE PERFORMANCE

A 4 stroke CI engine with water-cooled, electrical resistance, constant speed of 1500 RPM, and 5.2 kW output power stationary engine was used in this experiment work, and the specifications are mentioned in TABLE 2. The engine was linked to a computerized system that measured fuel consumption, and thermal efficiency.

TABLE 2: Specifications of Test Engine

|                     |   |
|---------------------|---|
| Engine nature       | Engine with four strokes and a water cooling system |
| Bore and stroke     | 87.5 and 110 mm                                     |
| Engine displacement | 661 cc  |

|                         |                            |
|-------------------------|----------------------------|
| Maximum power and speed | 5.2 kW at speed 1500 RPM   |
| Compression Ratio       | 17.5:1                     |
| Starting                | Cranking                   |
| Injection pressure      | 120-140 Kg/cm <sup>2</sup> |
| Response time           | 4 microseconds             |

### 3.1 Optimization

#### Taguchi Analysis

The Taguchi approach was used to investigate the optimization of performance parameters for Simarouba biodiesel blends and to determine the best operating conditions for each parameter. An L25 orthogonal array was chosen for the analysis using the Minitab software. In this analysis, three factors were analyzed at five levels as mentioned in TABLE 3. Blend (% of Biodiesel), load (kg), and speed (rpm) were taken as the input parameters, BP, BTE, and BSFC were performance parameters as represented in TABLE 4.

The SN ratios of each experiment are calculated and plotted and they are used to identify the optimum condition for a parameter. The optimum condition for a parameter has the highest S/N ratio. The S/N ratios of parameters are calculated using any of the three conditions i.e. Larger the better condition is for parameters that are favorable and are to be maximized. Here BP and BTE are analyzed using larger the better condition. The smaller the better condition is for the parameters which are undesirable or are the useless byproducts and are to be minimized. Here BSFC was analyzed using the smaller the better condition. Nominal is the better condition for parameters that are desirable only in a certain range of values and are to be restricted within that range of values.

Larger is better (BP and BTE) - S/N ratio =  $-10 \log_{10} \left[ \frac{\sum \left( \frac{1}{y^2} \right)}{n} \right]$

Smaller is better (BSFC) - S/N ratio =  $-10 \log_{10} \left[ \frac{\sum (y^2)}{n} \right]$

Nominal is better - S/N ratio =  $-10 \log_{10} (s^2)$

TABLE 3: Data inputs given in Minitab for Taguchi analysis

| Parameters | Blend (%) | Load (kg) | Speed (rpm) |
|------------|-----------|-----------|-------------|
| Level 1    | 100       | 2         | 1550        |
| Level 2    | 90        | 4         | 1575        |
| Level 3    | 80        | 6         | 1600        |
| Level 4    | 70        | 8         | 1625        |
| Level 5    | 60        | 10        | 1650        |

#### Response Outcomes

For the input parameters, best subsets Regression is carried out to find out dependent parameters for which the Regression analysis and Analysis of Variance are carried out, the response plots are plotted, and responses thus obtained are Response optimized to obtain the best suitable results.

## 4. RESULTS AND ANALYSES

### 4.1 Analysis of S/N Ratios

The S/N Ratio graphs were plotted as shown below for the three performance responses variables. The optimum conditions are determined in TABLE 5.

TABLE 5: Optimum Conditions

| Parameters | Blends | Load | RPM  |
|------------|--------|------|------|
| BP         | 90     | 10   | 1550 |
| BTE        | 100    | 10   | 1625 |
| BSFC       | 80     | 10   | 1550 |

TABLE 4: Response input Table (L25 Orthogonal Array)

| Blend (%) | Load (kg) | Speed (rpm) | BP (kW) | BTE (%) | BSFC (kg/KW-min) |
|-----------|-----------|-------------|---------|---------|------------------|
|           |           |             |         |         |                  |



|     |    |      |          |          |          |
|-----|----|------|----------|----------|----------|
| 100 | 2  | 1550 | 0.796692 | 19.06538 | 0.006231 |
| 100 | 4  | 1575 | 1.6706   | 39.51    | 0.00482  |
| 100 | 6  | 1600 | 2.4478   | 40.217   | 0.00372  |
| 100 | 8  | 1625 | 3.235111 | 41.17778 | 0.003156 |
| 100 | 10 | 1650 | 4.286714 | 42.19286 | 0.003029 |
| 90  | 2  | 1575 | 0.726909 | 16.873   | 0.007045 |
| 90  | 4  | 1600 | 1.65     | 38.95    | 0.0047   |
| 90  | 6  | 1625 | 2.471    | 41.44143 | 0.003229 |
| 90  | 8  | 1650 | 3.2646   | 39.285   | 0.0053   |
| 90  | 10 | 1550 | 4.878    | 40.724   | 0.0034   |
| 80  | 2  | 1600 | 0.771167 | 17.76667 | 0.005858 |
| 80  | 4  | 1625 | 1.672    | 38.13    | 0.0036   |
| 80  | 6  | 1650 | 2.452286 | 35.91714 | 0.003629 |
| 80  | 8  | 1550 | 3.246    | 37.69    | 0.0032   |
| 80  | 10 | 1575 | 4.055364 | 41.58818 | 0.002864 |
| 70  | 2  | 1625 | 0.687571 | 19.42429 | 0.031543 |
| 70  | 4  | 1650 | 1.651889 | 32.92556 | 0.005089 |
| 70  | 6  | 1550 | 2.469333 | 39.3     | 0.00315  |
| 70  | 8  | 1575 | 3.305889 | 39.54    | 0.004533 |
| 70  | 10 | 1600 | 3.99725  | 41.27875 | 0.003913 |
| 60  | 2  | 1650 | 0.743111 | 19.32556 | 0.0328   |
| 60  | 4  | 1550 | 1.6434   | 30.956   | 0.00424  |
| 60  | 6  | 1575 | 2.46125  | 38.735   | 0.0035   |
| 60  | 8  | 1600 | 3.296222 | 39.56667 | 0.003456 |
| 60  | 10 | 1625 | 4.017857 | 40.96143 | 0.001429 |

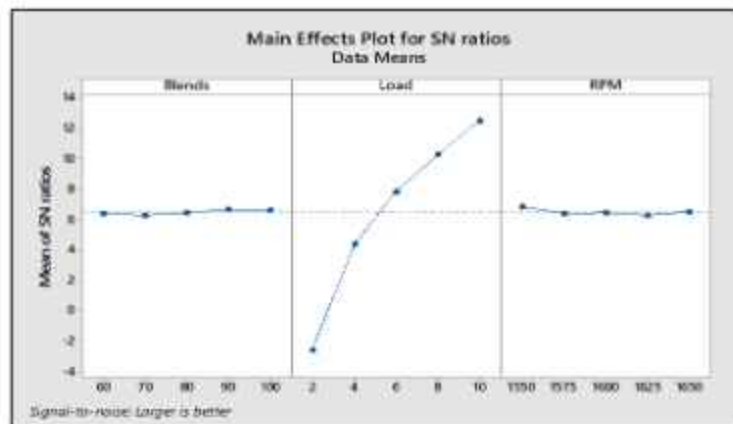

**Figure 1: S/N Ratio Plot for BP**

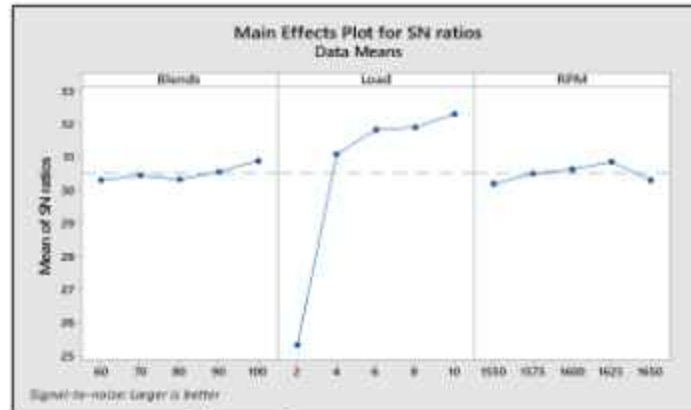

Figure 2: S/N Ratio Plot for BTE

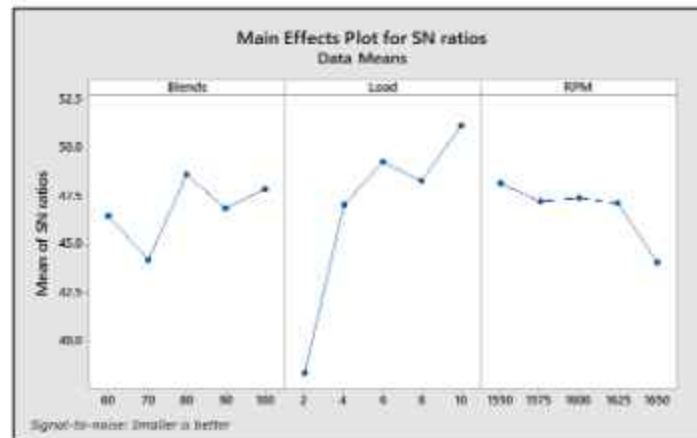

Figure 3: S/N Ratio Plot for BSFC

## 4.2 Response Outcomes

**4.2.1 BP:** Considering all statistics we can say that the best predictor model includes variables blend and load. These predictors are used to analyze their impact on BP.

### Regression Equation:

$$BP \text{ (kW)} = -0.337 + 0.00286 \text{ Blend} + 0.4308 \text{ Load}$$

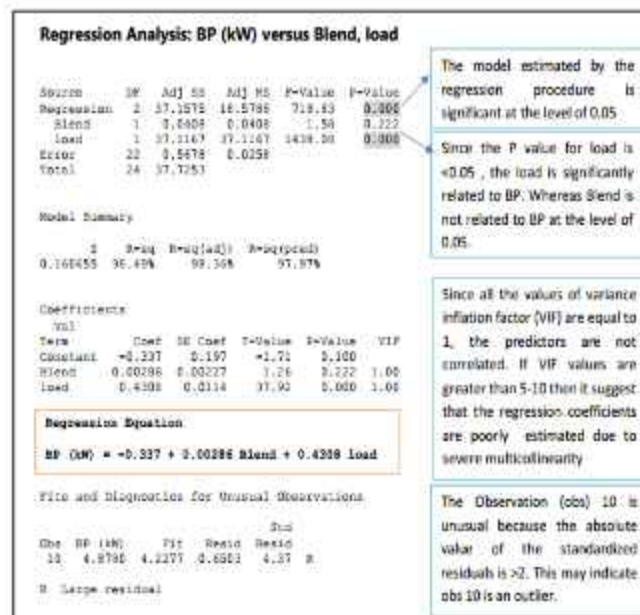

Figure 4: Regression analysis for BP

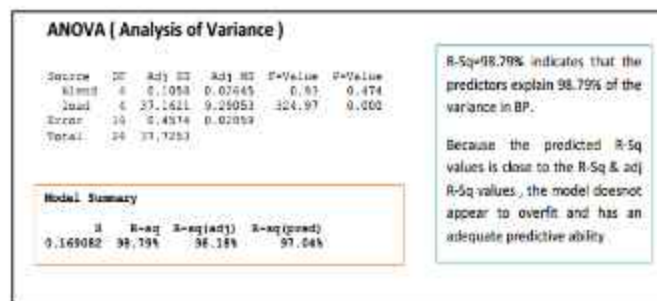

Figure 5: Analysis of Variance for BP

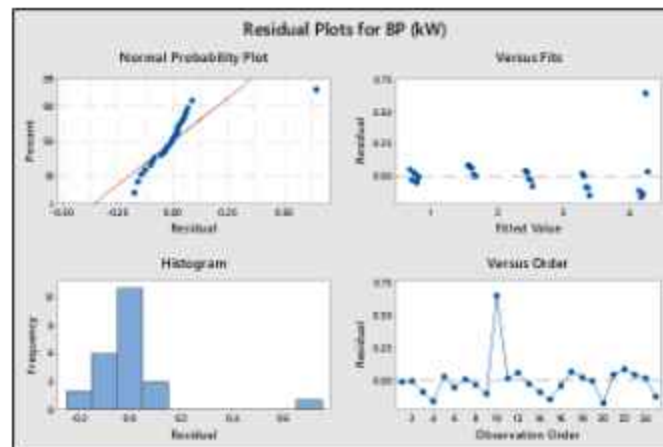

Figure 6: Residual plots for BP

**4.2.2 BTE:** Considering all statistics we can say that the best predictor model includes variables blend and load. These predictors are used to analyze their impact on BTE.

**Regression Equation:**

$$BTE (\%) = 15.37 + 0.0601 \text{ Blend} + 2.454 \text{ Load}$$

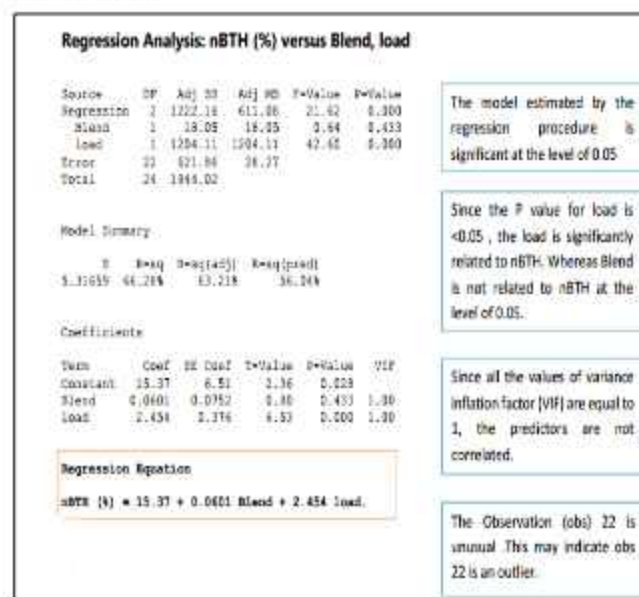

Figure 7: Regression analysis for BTE

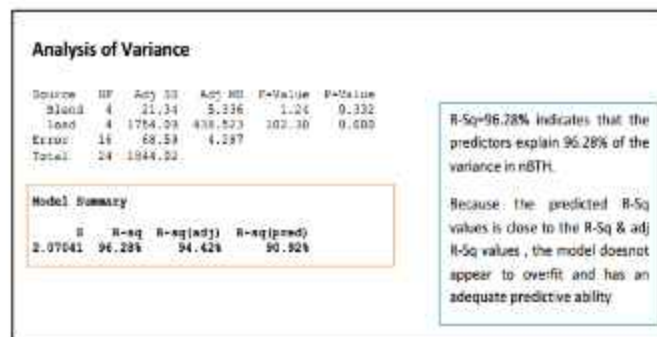

Figure 8: Analysis of Variance for BTE

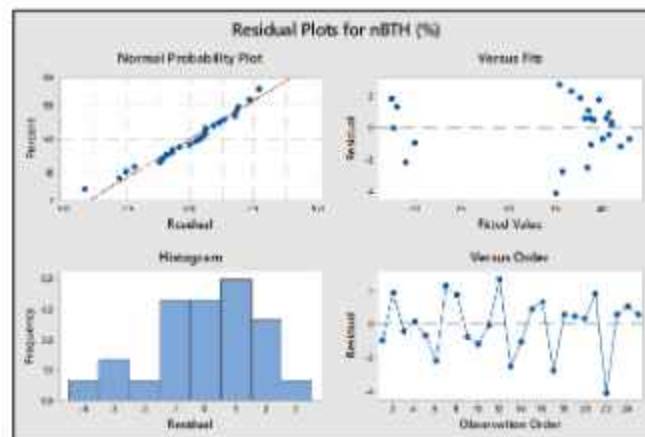

Figure 9: Residual plots for BTE

**4.2.3 BSFC:** Considering all statistics we can say that the best predictor model includes variables blend, load, and speed. These predictors are used to analyze their impact on BSFC.

**Regression Equation:**

$$BSFC (kg/kW-min) = -0.0752 - 0.000147 \text{ Blend} - 0.001405 \text{ Load} + 0.000064 \text{ Speed}$$

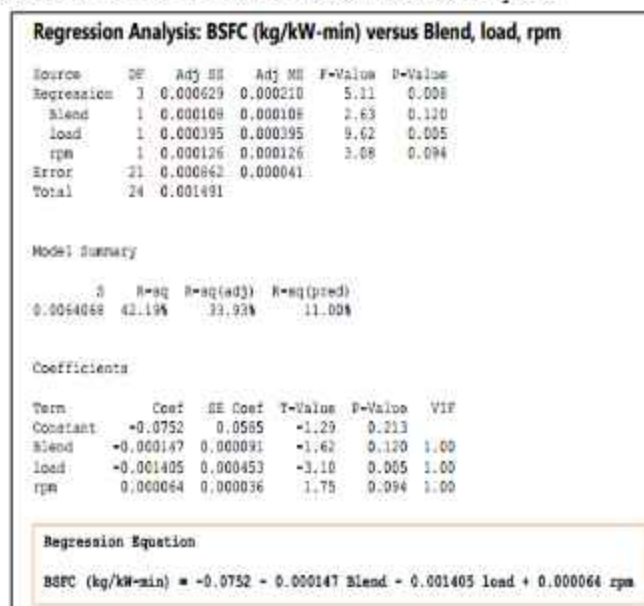

Figure 10: Regression analysis for BSFC

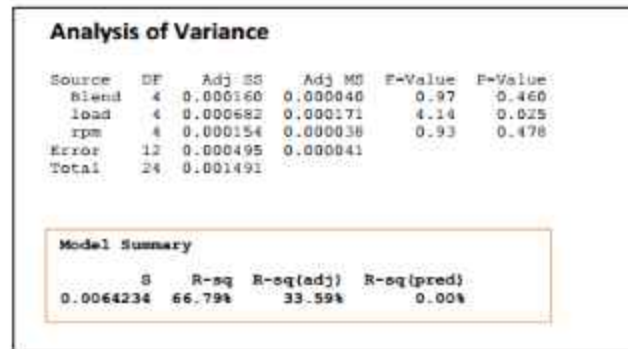

Figure 11: Analysis of Variance for BSFC

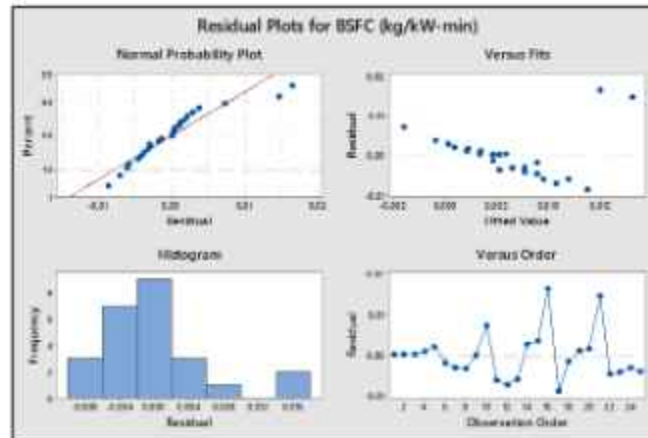

Figure 12: Residual plots for BSFC

## 5. CONCLUSIONS

This research focused on the use of Simarouba biodiesel blended with Simarouba straight vegetable oil as fuel in CI engines unlike most works in the literature which focus on Simarouba biodiesel and their blends with diesel. Properties of Simarouba oil, Simarouba biodiesel, and its blends were tested and the results obtained were within the standard range and comparable to that of diesel. The performance parameters like BP, BTE, and BSFC are optimized using the Taguchi method, regression analysis and ANOVA. The effects of the input parameters like load, blend, and speed on the performance parameters are analyzed and plotted. Based on the S/N ratios Taguchi analysis showed that the optimum conditions for BP are 90% blend, 10 kg load at 1550 rpm speed. For BTE optimum results were obtained at 100% blend, 10 kg load at 1625 rpm speed. For BSFC optimum results were obtained at 80% blend, 10 kg load at 1550 rpm speed. Regression analysis was performed to obtain the regression equations and it showed that load was the most significant factor on the performance parameters with a p-value lesser than 0.05 in all three cases. ANOVA determined that the R-sq value of BP, BTE, and BSFC are 98.79%, 96.28%, and 66.79% respectively.

## REFERENCES

- [1] P. Rakesh and K. Sandeep, "Extraction Of Simarouba Biodiesel And Experimental Investigation Of Its Suitability As Fuel For CI Engine," *Int. J. Prof. Eng. Stud.*, vol. 6, no. 1, pp. 55–65, 2015.
- [2] P. Jeyalakshmi, R. Subramanian, and N. Nedunchezian, "Biodiesel production from two stage esterification of simarouba glauca seed oil and its characterization," *Energy Sources, Part A Recover. Util. Environ. Eff.*, vol. 38, no. 9, pp. 1163–1168, 2016.
- [3] S. Mishra, M. Mohanty, S. Das, and A. Pattanaik, "Production of Bio-diesel (Methyl Ester) from Simarouba Glauca Oil," *Res. J. Chem. Sci. Res. J. Chem. Sci.*, vol. 2, no. 5, pp. 2231–606, 2012.
- [4] Mr. Naveena P, Mr. Vinod R, and Mr. Prashanth Reddy, "Experimental Investigation on the Performance and Emission Characteristics of Simarouba Glauca Oil as an Alternate Fuel in Variable Compression Ignition Engine," *Int. J. Eng. Res.*, vol. V4, no. 06, pp. 177–183, 2015.
- [5] A. R. Sayyad, P. Salunke, and S. Jadhav, "Simarouba Biodiesel Blends as an Alternative Fuel for Compression Ignition Engine

- and Its Optimization Using Multiple Regression Analysis on CI Engine Performance (BTE) and Emissions (CO<sub>2</sub>, HC) Characteristics," *SAE Tech. Pap.*, vol. Part F1298, no. September, 2017.
- [6] A. S. Muruli, D. G. Rajakumar, and H. T. Sagar, "Performance and emission characteristics of a CI engine using preheated Simarouba biodiesel blends," *AIP Conf. Proc.*, vol. 2039, 2018.
- [7] B. Venkatanarayana and C. Ratnam, "Selection of optimal performance parameters of DI diesel engine using Taguchi approach," *Biofuels*, vol. 10, no. 4, pp. 503–510, 2019.
- [8] G. Pohit and D. Misra, "Optimization of performance and emission characteristics of diesel engine with biodiesel using grey-taguchi method," *J. Eng. (United Kingdom)*, vol. 2013, 2013.
- [9] B. Deepanraj, M. Srinivas, N. Arun, G. Sankaranarayanan, and P. Abdul Salam, "Comparison of jatropha and karanja biofuels on their combustion characteristics," *Int. J. Green Energy*, vol. 14, no. 15, pp. 1231–1237, 2017.
- [10] B. Deepanraj, P. Lawrence, R. Sivashankar, and V. Sivasubramanian, "Analysis of pre-heated crude palm oil, palm oil methyl ester and its blends as fuel in a diesel engine," *Int. J. Ambient Energy*, vol. 37, no. 5, pp. 495–500, 2016.
- [11] B. Ghaleppa, N. Suraj Hiremath, and Rana Pratapreddy, "Production and Utilization of Useful Fuel from Waste Cooking Oil and Waste Lubrication Oil: Performance and Emission-quality in a Naturally Aspirated Diesel Engine," *Int. J. Innovative Tech. and Exploring Engg.*, vol. 9, no. 9, pp. 79-84, 2020.
- [12] Kumar Upender and Gupta Pradeep, "Performance and Emission Testing of Diesel Engine Using Blends of Biodiesel from Castor Oil and Neem Oil Prepared Using Lithium-Doped CaO Nano-Catalyst," *Emerging Trends in Mechanical Engg.*, pp. 259-278, 2021.
- [13] Fazal Haseeb and H. H. Masjuki, "Biodiesel feasibility study: An evaluation of material compatibility; Performance, emission and engine durability," *Renewable and Sustainable Energy Reviews*, vol. 15, no. 2, pp. 1314-1324, 2011.
- [14] Government of India, Ministry of New and Renewable Energy, "National Policy of Biofuel, New Delhi, India", pp. 1-18, 2012.
- [15] D. Kadam and S. Jadhav, "Optimization of Vibration, Performance and Emission of C. I. Engine Operated on Simarouba Biodiesel Using Taguchi and Multiple Regression Analysis," *SAE Tech. Pap.*, 2017-01-2137, 2017.
- [16] H. Manjunath, Omprakash Hebbal, and K. Hemachandra Reddy, "Process Optimization for Biodiesel Production from Simarouba, Mahua, and Waste Cooking Oils," *Int. J. Green Energy*, vol. 12, no. 4, pp. 424-430, 2015.
- [17] Godiganur Sharanappa, C. H. Suryanarayana Murthy, and Rana Prathap Reddy, "6BTA 5.9 G2-1 Cummins engine performance and emission tests using methyl ester mahua (*Madhuca indica*) oil/diesel blends," *Renewable Energy*, vol. 34, no. 10, pp. 2172-2177, 2009.

## FABRICATION OF REMOTE-CONTROL MOTORIZED SCREW JACK

<sup>1</sup>Lingesh Gowda. R, <sup>2</sup>Mohith. J, <sup>3</sup>Kiran Kashyap. GB, <sup>4</sup>Mr. Ranganath.N

<sup>1,2,3</sup> Students

<sup>4</sup>Assistant Professor

Dept. of Mechanical Engineering  
K.S. Institute of Technology, Bangalore 560109

### ABSTRACT

*The introduction of the concept of remote-controlled motorized screw jack. when the weight of the vehicle exceeds certain limit, it cannot be lifted by the person, in such cases we are in need of a jack. There are few jacks to lift the vehicle but it is operated manually. When it is done automatic it becomes more convenient to use. In order to implement this idea, we have developed a system called motorized jack which is controlled through android app, by using this we can easily lift the jack up and down thus helps to reduce the burden of the worker. The main reason to fabricate the motorized screw jack is to avoid the fatigue of human during lifting of the load. The project is less cost and good efficient for operating. This jack can lift a vehicle weight of 600 to 800kg which is more use for garage workers. This jack can be operated using an android mobile. Bluetooth module is connected to the controller to take the commands from the mobile so that the motor can be rotated to lift the jack. motor runs through the battery. Here we are using arduono as our controller and Bluetooth module.*

Keywords: DC Motor, Automatic car jack, Bluetooth, Android app, IOT.

### 1. INTRODUCTION

This project work titled “**remote controlled motorized screw jack**” has been conceived having studied the difficulty in lifting the any type of light vehicles through smart phone apps. Our survey in the regard in several car owners or drivers, revealed the facts that mostly some difficult methods were adopted in lifting the vehicles where in need of maintenance, repair and while the tyre gets punctured. A screw jack is a portable device consisting of a screw mechanism used to raise or lower the load and lift heavy objects.

There are mainly two types of jacks-hydraulic and mechanical. A hydraulic jack consists of a cylinder and piston mechanism. The movement of the piston rod is used to raise or lower the load. Mechanical jacks can be either hand operated or power driven. Jacks are used frequently in raising cars so that a tire can be changed.

Nowadays smart phones are becoming more powerful and have gradually turned into an all-purpose portable device and provided people for their daily use. Bluetooth is mainly used for data exchange; add new features to smart phones. Bluetooth technology, shows its advantage by integrating with smart phones. It has changed how people use digital device at anywhere, and has transferred traditional wired digital devices into wireless devices. smart phones have gradually turned into an all-purpose portable device and provided people for their daily use. Android has complete software package consisting of an operating system, middleware layer and core applications. In this paper we present a screw jack controlled by mobile phone, tablets. In our work, move the screw jack upward, backward by the android application such as Bluetooth Terminal. The operation is made to be simple that even an unskilled labour can handle, this is an era of automation where it is broadly defined as replacement of manual effort by mechanical power in all degrees of automation.

### 2. MATERIALS AND METHODS

#### 2.1 Screw Jack



FIGURE 1. Screw jack

A screw jack consists of a heavy-duty vertical screw with a load table mounted on its top, which screws into a threaded hole in a stationary support frame with a wide base resting on the ground. A rotating collar on the head of the screw has holes into which the handle, a metal bar, fits. When the handle is turned clockwise, the screw moves further out of the base, lifting the load resting on the load table. In order to support large load forces, the screw is usually formed with ACME threads.

### 2.1.1 Specifications of screw jack

- Rugged alloyed steel construction with heavy duty steel frame and saddle
- Oversize: 4 ¼ inch wide base
- Lift range: 3 inches 15 inches
- Lift weight: 1000kg

## 2.2 Lead Acid Battery



FIGURE 2. Lead acid battery

The lead–acid battery consists of two electrodes submerged in an electrolyte of sulfuric acid. The positive electrode is made of grains of metallic lead oxide, while the negative electrode is attached to a grid of metallic lead. Lead–acid batteries are classified into two types: flooded and valve-regulated. Flooded lead–acid batteries are less expensive but require more maintenance and ventilation than the valve-regulated lead–acid batteries.

### 2.2.1 Specifications of lead acid battery

- voltage : 12 V
- current : 7.5 amps

## 2.3 DC MOTOR



FIGURE 3. DC motor

A DC motor is any of a class of electrical machines that converts direct current electrical power into mechanical power. A direct current, or DC, motor is the most common type of motor. DC motors normally have just two leads, one positive and one negative. If you connect these two leads directly to a battery, the motor will rotate. If you switch the leads, the motor will rotate in the opposite direction.



### 2.3.1 Specifications of DC Motor

- voltage : 12 V
- current : 5amps
- speed : 60rpm

### 2.4 Bluetooth module



FIGURE 4. Bluetooth module

Among the four popular wireless connections that often implemented in HAS project, Bluetooth is being chosen with its suitable capability. Bluetooth with globally available frequencies of 2400Hz is able to provide connectivity up to 100 meters at speed of up to 3Mbps depending on the Bluetooth device. Prior to implementation of Bluetooth-based application on the phone, several software packages are required which include Java Development Kit (JDK), the Eclipse software environment, Android Development Tools (ADT) and Android SDK (Software Development Kit).

### 2.5 Relay switch



FIGURE 5. Relay switch

We are using SPST (Single-Pole Single-Throw) relay. Two relays are used for backward and forward motion of motor. A relay is an electrically worked switch. Current moving through the loop of the transfer makes an attractive field which draws in a switch and changes the switch contacts. The coil current can be on or off. So transfers have two switch positions and they are twofold toss (changeover) switches. Transfers permit one circuit to switch a second circuit which can be totally discrete from the first. The connection is attractive and mechanical.

### 2.6 Microcontroller



FIGURE 6. Microcontroller

Microprocessors and microcontrollers are widely used in embedded systems products. Microcontroller is a programmable device. A microcontroller has a CPU in addition to a fixed amount of RAM, ROM, I/O ports and a timer embedded all on a single chip. The fixed amount of on-chip ROM, RAM and number of I/O ports in microcontrollers makes them ideal for many applications in which cost and space are critical. The 8052 is an 8-bit processor, meaning that the CPU can work on only 8 bits of data at a time. Data larger than 8 bits has to be broken into 8-bit pieces to be processed by the CPU.

### 3. BLOCK DIAGRAM

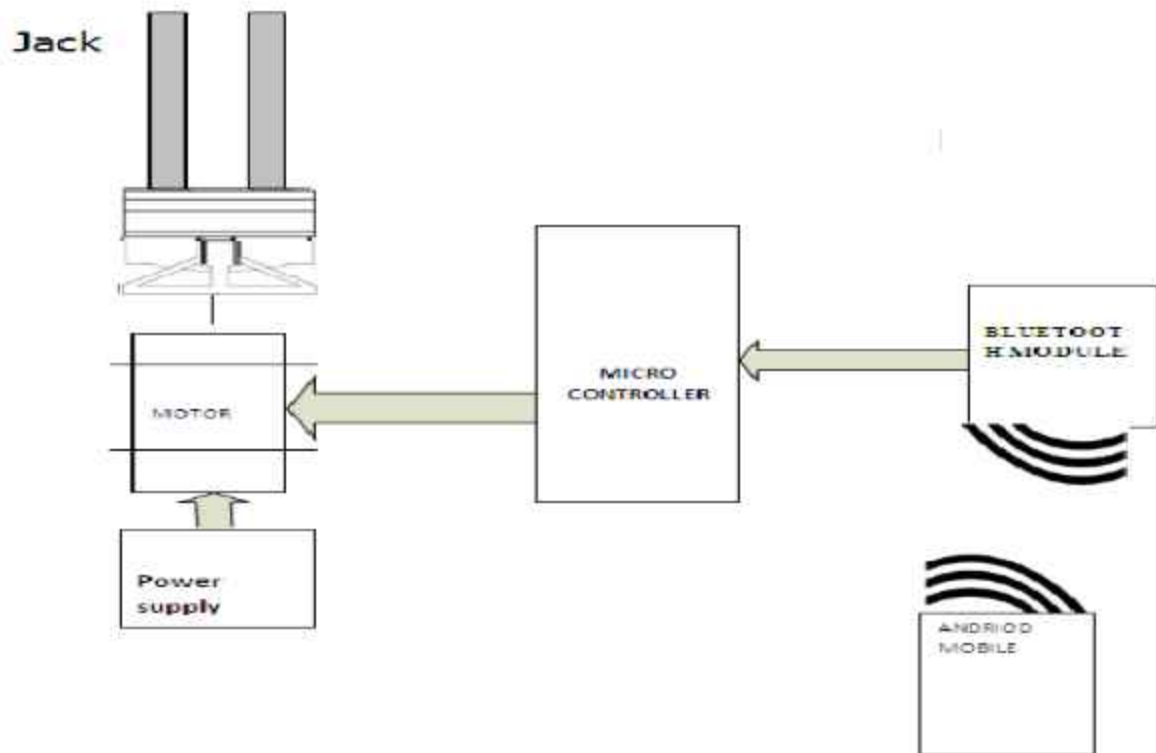

### 4. WORKING PRINCIPLE

An Android controlled automobile project that allows user to control a battery powered automobile wireless through an android application. The system uses a bluetooth modem as a medium to transmit signals between the android based phone and to the Bluetooth jack. The commands are sent in the form of string variables by the android application through an active bluetooth connection. These string variables are then received by bluetooth modem and then forwarded to the Microcontroller.

The microcontroller now processes the data sent by bluetooth modem and checks for user commands. On recognizing direction commands sent by user (Forward/Backward), the microcontroller sends signals to appropriate driver IC's. The driver IC's now operate motors to achieve the desired movement of the automobile as sent by microcontroller.

The lead-acid battery is used to drive the D.C motor. The D.C motor shaft is connected to the spur gear. If the power is given to the D.C motor, it will run so that the spur gear also runs to the slow speed of the D.C motor. The screw jack and moves the piston upward, so that the vehicle lifts from ground. The vehicle is lifted by using the lifting flat form in the top of the screw jack. The motor is drawn supply from the battery. The lifting and uplifting is done by changing the battery supply to the motor simply.

### 5. CONCLUSION

This project has been made to help the workers who are working in the automobile garages, service station and also elderly people. This project reduces the effort of lifting heavy vehicle weight and also reduces the time. This project has also reduced the cost involved in the concern. This jack can lift a vehicle weight of 600 to 800kg which is more useful for garage workers. This jack can be operated using an android mobile. Bluetooth module is connected to the controller to take the commands from the mobile so that the motor can be rotated to lift the jack. Motor runs through the battery. Here we are using arduino as our controller and Bluetooth module. The whole model can be operated anywhere.

## ACKNOWLEDGEMENT

We would like to express our profound gratitude to our project guide Mr Ranganath N, Assistant professor, KSIT for the guidance, monitoring and cooperation, and our friends and their constant encouragement in making this project successful.

## REFERENCES

- [1] R. S. Khurmi, a text book of machine design, Eurasia Publishing House PDF.
- [2] Dr. Sandhu Singh "Machine Design" Khanna Publishers, Delhi, 1997.
- [3] (Arduino, iOS, Android and Technology Tips)
- [4] Heidi Monson (1999) Bluetooth technology and implementations, John Wiley & Sons.
- [5] Piyare, R. and Tazil, M. (2011) "Bluetooth based home automation system using Android phones". IEEE 15TH International Symposium on Consumer Electronics (ISCE), 14-17 June 2011, Singapore.
- [6] Lokhande Tarachand G., Chatpalliwar Ashwin S. And Bhotar Amar A., "Optimizing Efficiency of Square Threaded Mechanical Screw Jack by Varying Helix Angle", International Journal of Modern Engineering Research (IJMER) Vol.2 Issue.1, pp. 504-508, Jan-Feb 2012.

## DESIGN AND ANALYSIS OF DISHED ENDS

Mohammad Saif Ulla Ameen<sup>1</sup>, Rahul B.N<sup>2</sup>, Rahul P<sup>3</sup>, Syed Ali Faizan Khadr<sup>4</sup>, Nagabhushana M<sup>5</sup>

<sup>1234</sup> UG-students

<sup>5</sup>Associate Professor

Department of Mechanical Engineering  
K.S. Institute of Technology Bangalore -560109

### ABSTRACT

*Dished ends are an important element for pressure vessels and boilers. They cover both ends of the pressure vessel and have wide applications. They are used in nuclear power plants, thermal power plants, and refineries. Usually, the design of dished ends is according to codes like ASME, Indian Standard, etc. The dish is supported by a weld. Internal pressure load, self-weight, the volume of fluid used in the vessel, and seismic load, these loading factors should be taken into consideration while designing. The joint should be considered while designing so that it can withstand various loads. The design for thickness is carried out with reference to Indian Standard 4049. In this paper, the pressure vessel with different end dishes is subjected to internal pressure. The dish ends have been designed for an operating pressure of 2MPa which will be useful for storage applications. Calculations are made to find the thickness of the dish end for the operating pressure. Non-linear axisymmetric Finite Element Analysis considering both geometric and material non-linearity has been performed in SOLIDWORKS software to estimate the stress in the dish of the pressure vessel.*

**Keywords:** Dished ends, Finite element analysis, Formed head, Crown radius, Knuckle radius, Straight face, Factor of safety, Displacement model, Von-mises stress, Maximum allowable stress, and design pressure.

### 1. INTRODUCTION

A dished end is also called a dished head or tank head. It is an important pressure element for pressure vessels and boilers. The dished end is usually used at both ends of the pressure vessel and welded with the shell. According to different geometric shapes, it can be divided into elliptical head, tori-spherical head, hemispherical head, spherical head, conical head, flat head, etc. Hemispherical heads are used for high-pressure vessels and boilers, elliptical heads are used for medium pressure vessels and boilers, whereas tori-spherical heads are used for low-pressure vessels and boilers.

There are different types of dish ends, they are as followed

- Flat Head.
- Ellipsoidal head.
- Tori-spherical head.
- Hemispherical head.

Commonly used terms in above listed dished ends are

- Inside Diameter (ID)
- Crown radius (CR)
- Knuckle Radius (KR)
- Dish End Total Height (H)
- Straight Face (SF)
- Thickness (t)

**Applications of Dished ends:** - A pressure vessel is a container designed to hold liquids or gases at a pressure often different from the surrounding atmosphere. Due to the nature of the substances being stored, which in certain cases may be hazardous, it is imperative that the construction material meets the exacting safety standards required for the application. Depending on the size and purpose the applications of dished ends vary from one sector to another and the type of pressure vessel and its geometry.

Major Applied sectors are: Petrochemical plants.

- Pharmaceutical industry.
- Oil and gas industry.
- Nuclear power industry.
- Biotechnology.
- Food industry

## 2. MATERIAL

The material used is FE 410 Steel.



The material properties are as follows



| Structural steel | Density               | Young's modulus                     | Poisson's ratio              | Modulus of rigidity                        | Ultimate tensile stress | Yield stress |
|------------------|-----------------------|-------------------------------------|------------------------------|--|-------------------------|--------------|
| 2062:2011        | 7850kg/m <sup>3</sup> | 2*10 <sup>5</sup> n/mm <sup>2</sup> | Elastic: 0.3<br>Plastic: 0.5 | 0.739*10 <sup>5</sup><br>n/mm <sup>2</sup> | 490MPa                  | 320MPa       |

## 3. METHODOLOGY

To achieve the design and analysis of the dish ends, calculations are made in reference to Indian Standard 2825 – 1969 to determine the thickness for internal pressure of 2MPa. The calculations made resulted in a thickness of about 50mm. Solidworks application is used to achieve 3D modelling, drafting, and Finite Element Analysis of the dish end. The analysis is done to determine Von-mises stress, resultant displacement, and factor of safety for all the formed ends i.e. tori-spherical dish end, ellipsoidal dish end, and hemispherical dish end.

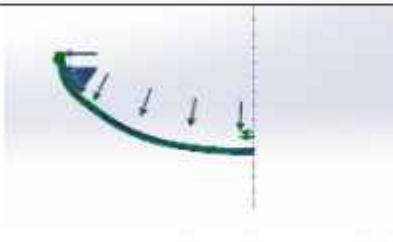
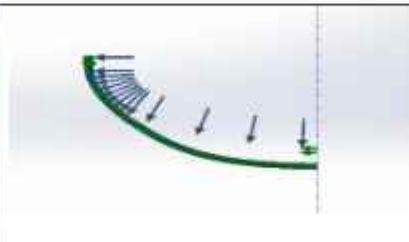
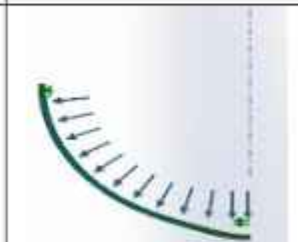
## 4. RESULT and DISCUSSION

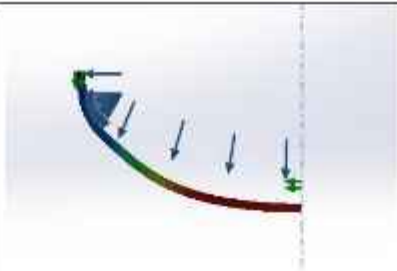
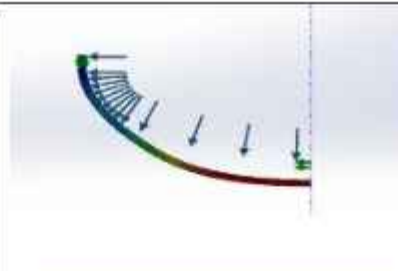
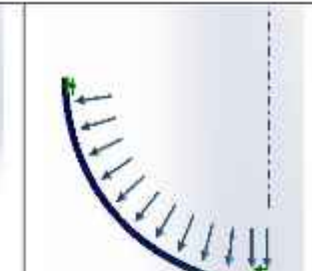
| Type of dish end                       | Tori-spherical  | Ellipsoidal  | Hemispherical   |  |  |   |     |     |  |  |   |     |     |  |  |
|--|---|--|---|--|--|---|-----|-----|--|--|---|-----|-----|--|--|
| Thickness                              | 50mm  | 50mm   | 50mm  |  |  |   |     |     |  |  |   |     |     |  |  |
| Internal pressure                      | 2MPa  | 2MPa   | 2MPa  |  |  |   |     |     |  |  |   |     |     |  |  |
| 3D Model                               |    |  |  |  |  |   |     |     |  |  |   |     |     |  |  |
| Von-mises stress                       |  <table border="1" data-bbox="384 1727 778 1816"> <thead> <tr> <th>Min</th> <th>Max</th> </tr> </thead> <tbody> <tr> <td>6.673*10<sup>6</sup>N/m<sup>2</sup></td> <td>2.030*10<sup>8</sup>N/m<sup>2</sup></td> </tr> </tbody> </table> | Min  | Max   | 6.673*10 <sup>6</sup> N/m <sup>2</sup> | 2.030*10 <sup>8</sup> N/m <sup>2</sup> |  <table border="1" data-bbox="799 1727 1209 1816"> <thead> <tr> <th>Min</th> <th>Max</th> </tr> </thead> <tbody> <tr> <td>7.568*10<sup>5</sup>N/m<sup>2</sup></td> <td>1.259*10<sup>8</sup>N/m<sup>2</sup></td> </tr> </tbody> </table> | Min | Max | 7.568*10 <sup>5</sup> N/m <sup>2</sup> | 1.259*10 <sup>8</sup> N/m <sup>2</sup> |  <table border="1" data-bbox="1230 1727 1528 1816"> <thead> <tr> <th>Min</th> <th>Max</th> </tr> </thead> <tbody> <tr> <td>1.132*10<sup>6</sup>N/m<sup>2</sup></td> <td>9.947*10<sup>7</sup>N/m<sup>2</sup></td> </tr> </tbody> </table> | Min | Max | 1.132*10 <sup>6</sup> N/m <sup>2</sup> | 9.947*10 <sup>7</sup> N/m <sup>2</sup> |
| Min                                    | Max   |  |   |  |  |   |     |     |  |  |   |     |     |  |  |
| 6.673*10 <sup>6</sup> N/m <sup>2</sup> | 2.030*10 <sup>8</sup> N/m <sup>2</sup>  |  |   |  |  |   |     |     |  |  |   |     |     |  |  |
| Min                                    | Max   |  |   |  |  |   |     |     |  |  |   |     |     |  |  |
| 7.568*10 <sup>5</sup> N/m <sup>2</sup> | 1.259*10 <sup>8</sup> N/m <sup>2</sup>  |  |   |  |  |   |     |     |  |  |   |     |     |  |  |
| Min                                    | Max   |  |   |  |  |   |     |     |  |  |   |     |     |  |  |
| 1.132*10 <sup>6</sup> N/m <sup>2</sup> | 9.947*10 <sup>7</sup> N/m <sup>2</sup>  |  |   |  |  |   |     |     |  |  |   |     |     |  |  |

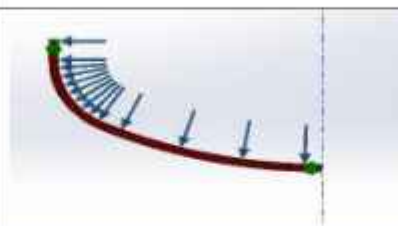
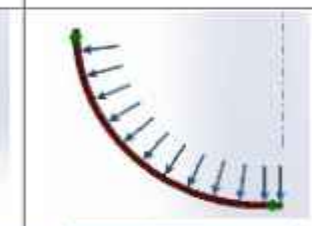
| Deflection                       |    |  |  |                                  |         |  |  |     |                                  |         |   |     |     |                                  |                                  |
|----------------------------------|---|--|---|----------------------------------|---------|--|--|-----|----------------------------------|---------|---|-----|-----|----------------------------------|----------------------------------|
|                                  | <table border="1" data-bbox="391 470 774 571"> <thead> <tr> <th>Min</th> <th>Max</th> </tr> </thead> <tbody> <tr> <td><math>2.471 \times 10^{-3} \text{mm}</math></td> <td>2.310mm</td> </tr> </tbody> </table> | Min  | Max   | $2.471 \times 10^{-3} \text{mm}$ | 2.310mm | <table border="1" data-bbox="813 470 1197 571"> <thead> <tr> <th>Min</th> <th>Max</th> </tr> </thead> <tbody> <tr> <td><math>1.454 \times 10^{-3} \text{mm}</math></td> <td>1.491mm</td> </tr> </tbody> </table> | Min  | Max | $1.454 \times 10^{-3} \text{mm}$ | 1.491mm | <table border="1" data-bbox="1252 504 1516 593"> <thead> <tr> <th>Min</th> <th>Max</th> </tr> </thead> <tbody> <tr> <td><math>1.587 \times 10^{-1} \text{mm}</math></td> <td><math>6.794 \times 10^{-1} \text{mm}</math></td> </tr> </tbody> </table> | Min | Max | $1.587 \times 10^{-1} \text{mm}$ | $6.794 \times 10^{-1} \text{mm}$ |
|                                  | Min   | Max  |   |                                  |         |  |  |     |                                  |         |   |     |     |                                  |                                  |
| $2.471 \times 10^{-3} \text{mm}$ | 2.310mm   |  |   |                                  |         |  |  |     |                                  |         |   |     |     |                                  |                                  |
| Min                              | Max   |  |   |                                  |         |  |  |     |                                  |         |   |     |     |                                  |                                  |
| $1.454 \times 10^{-3} \text{mm}$ | 1.491mm   |  |   |                                  |         |  |  |     |                                  |         |   |     |     |                                  |                                  |
| Min                              | Max   |  |   |                                  |         |  |  |     |                                  |         |   |     |     |                                  |                                  |
| $1.587 \times 10^{-1} \text{mm}$ | $6.794 \times 10^{-1} \text{mm}$  |  |   |                                  |         |  |  |     |                                  |         |   |     |     |                                  |                                  |
| Factor of safety                 |    |  |  |                                  |         |  |  |     |                                  |         |   |     |     |                                  |                                  |
|                                  | <table border="1" data-bbox="263 851 1252 918"> <thead> <tr> <th>Min</th> <th>Max</th> </tr> </thead> <tbody> <tr> <td>1.392</td> <td><math>4.236 \times 10^1</math></td> </tr> </tbody> </table>               |  | Min   | Max                              | 1.392   | $4.236 \times 10^1$  | <table border="1" data-bbox="1268 840 1508 907"> <thead> <tr> <th>Min</th> <th>Max</th> </tr> </thead> <tbody> <tr> <td>2.842</td> <td><math>2.498 \times 10^2</math></td> </tr> </tbody> </table> | Min | Max                              | 2.842   | $2.498 \times 10^2$   |     |     |                                  |                                  |
|                                  | Min   | Max  |   |                                  |         |  |  |     |                                  |         |   |     |     |                                  |                                  |
| 1.392                            | $4.236 \times 10^1$   |  |   |                                  |         |  |  |     |                                  |         |   |     |     |                                  |                                  |
| Min                              | Max   |  |   |                                  |         |  |  |     |                                  |         |   |     |     |                                  |                                  |
| 2.842                            | $2.498 \times 10^2$   |  |   |                                  |         |  |  |     |                                  |         |   |     |     |                                  |                                  |
|                                  |   |  |   |                                  |         |  |  |     |                                  |         |   |     |     |                                  |                                  |

Chemicals, fuels, and gases exert a maximum internal pressure of 2MPa and the thickness of the dished ends is calculated for the same internal pressure. The analysis for the dished ends is made for the same pressure. The analysis is done for Von-mises stress, deflection, and factor of safety. The result of the analysis declared the modelled parts as safe.

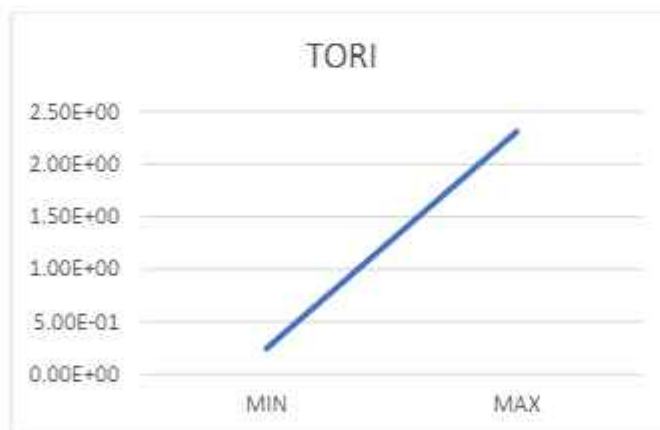

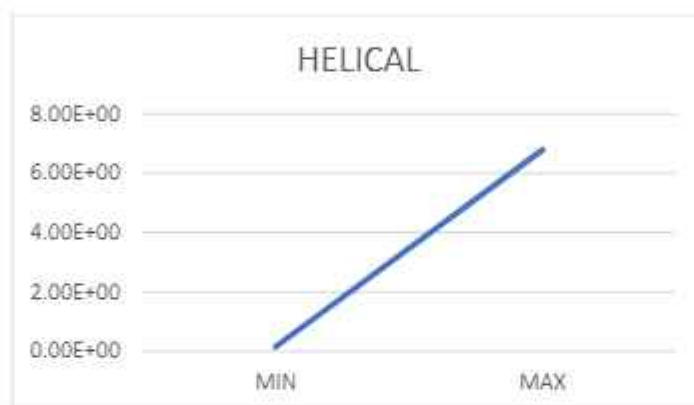
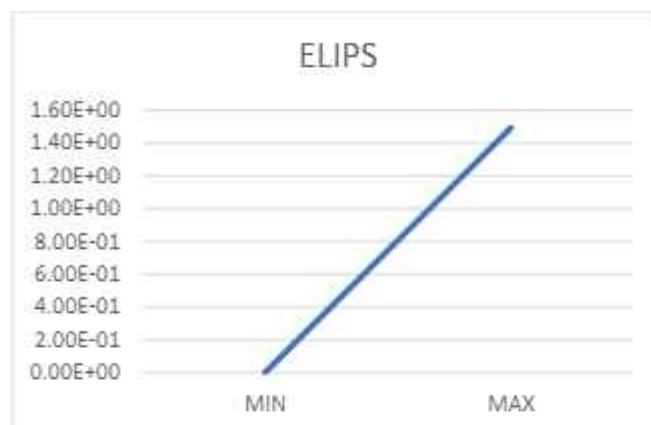

From the above graphs it can be concluded that tori-spherical dish ends have minimum deflection under internal pressure of 2MPa and thickness of 50mm when compared with other types of dish ends.

## 5. CONCLUSION

This paper compares the formed head i.e. tori-spherical head, ellipsoidal head and hemispherical head by means of deflection in each head.

## ACKNOWLEDGMENT

Our most sincere and grateful acknowledgment to the holy sanctum of K.S. INSTITUTE OF TECHNOLOGY, the temple of learning, for giving us the opportunity to the degree in Mechanical Engineering and thus helping us to shape our career. First and foremost we would like to express our gratitude to Dr. Dilip Kumar K, Principal, K S Institute of Technology for his whole hearted support during our stay at KS Institute of technology.

We express our sincere thanks to Dr. Nirmala L, Student project coordinator, K S Institute of Technology for having given this opportunity and support to carry out our project work.

We take immense pleasure in thanking Dr. Umashankar M, Professor and Head of the Department, Mechanical Engineering for having given this opportunity and support to carry out our project work.

## REFERENCES

- [1] Bandrupalli Praneeth, T.B.S.Ra, "Finite Element Analysis of Pressure Vessel and Piping Design", International Journal of Engineering Research and Applications (IJERA) ISSN: 2248-9622 Vol. 2, Issue 1, Jan-Feb 2012, pp. 355-361
- [2] Siva Krishna Raparla & T.Seshaiah, "Design and analysis of multilayer high pressure vessels", International Journal of Engineering Research and Applications (IJERA) -Vol. 2, Issue 1, Jan-Feb 2012, pp. 355-361
- [3] Bogdan Szybiński, "Design of flat ends in pressure boilers with circular and elliptical stress relieve grooves", Applied Mechanics and Materials, vol. 477-478, Trans Tech Publications, Ltd., Dec. 2013, pp. 49-53
- [4] Suresh c. Maidargi, "Chemical process equipment: design and drawing (volume 1)", PHI Learning; 2nd edition -1 August 2015
- [5] Bhattacharyya, "Introduction To Chemical Equipment Design Mechanical Aspects", CBS publications 1st edition 1 January 2017

- [6] P. D. Kulkarni ,” Chemical Instrumentation and Process Control”, Nirali Prakashan, Educational Publishers; 5th ed. edition 1 March 2019 .
- [7] Sagarsingh Kushwah ,Shreyash kumar ,Parekh Harsh Mistry ,Jainil Darji ,Rutvik Gandhi,” Analysis of cylindrical pressure vessels with dissimilar ends and material comparison”, ISSN 2214-7853 Issue 2020.
- [8] Korukonda sivaparvathiSri.Palle Prasad,” Design and static thermal analysis of different pressure vessel heads and materials using FEM”, Open Access International Journal Of Science And Engineering -Volume 5 Issue 8 , August 2020.



## ENVIRONMENTAL IMPACTS AND EMISSION GUIDELINES ON HYBRID VEHICLES

Shubham Anil Pandey

Student

Department of Mechanical Engineering  
Sir M. Visvesvaraya Institute of Technology  
Bengaluru-562157

### ABSTRACT

*Living in 21<sup>st</sup> century the technology is rapidly changing as it is achievement to behold as it makes human lives easier. With increase of technology has also lead the increase in vehicles and factories leading to pollution, destruction of natural resources at large scale. The environmental impacts of electric and hybrid vehicles include effects on mobility and travel, electricity supply system operation, petroleum and other fuel consumption, air pollution and traffic noise. The fuel which is mix is used by power stations and also determine air pollution impacts, as emissions coming from vehicles is decreased but emission in power plants increases which is main con in manufacturing hybrid and electric vehicles. As when it comes to air pollution the sound made by vehicles decreases gradually, it benefits greatly towards air pollution.*

### 1. INTRODUCTION

Over the years the automobile industry has evolved over the years, the advancements have reached where the vehicles are being manufactured which are eco-friendlier, safer and money saver on long term basis. Combination of regular engine with electric motor, hybrids present a more practical option on being safer towards environment. The objective of this journal will be aiming at understanding the effect of hybrid cars and electric vehicles on environment. An analysis of the hybrid cars will be carried out along with evaluating the advantages and disadvantages of said vehicles.

### 2. CURRENT SCENARIO OF AIR POLLUTION (INDIA)

The current Air Quality Index (AQI) in India is 111 POOR Quality. The current concentration of PM<sub>2.5</sub> (May 2022) is 37 $\mu\text{g}/\text{m}^3$ . The World Health Organisation (WHO) recommends 25  $\mu\text{g}/\text{m}^3$  as the threshold concentration of PM<sub>2.5</sub>. Currently the concentration is 1.48 times the recommended limit 1.48. As in India generally the air quality starts deteriorating in late October. The winters are the worst-hit season in terms of air pollution.

#### Advantages of Hybrid Vehicle

- Hybrid vehicles have increased capability and efficiency to maintain and manage the car, reaction towards situations at lower battery power is quick by switching to gasoline engine.
- Using electric motor during travelling in city as it saves lot of fuel by having so many stops.
- As when car runs on motor it consumes zero fuel which saves lot of money and keeps it in budget.
- Noise pollution is near to minimum which is very effective near schools, hospitals, residential areas etc.

#### Disadvantages of Hybrid Vehicle

- Hybrid vehicles are very expensive than gasoline vehicles.
- Battery power and charging might be issue sometimes even a light kept all night leaves battery empty.
- Pedestrians might have issue because of silent cars they can't hear vehicle sound which might lead to dangerous accident.

### 3. BATTERY AND ITS TYPE USED IN HYBRID VEHICLES

3.1 Nickel Metal Hydride: Nickel-metal Hydride; abbreviated to NiMH, is the most common types of batteries currently being used in hybrid cars. These batteries are larger than lead acid batteries thus requiring more space therefore, batteries are placed in back side of the car, either under back seat of the car or in the boot of the car.



FIGURE 1: Battery

**Advantages**

- NiMH battery packs are less expensive and more predictable when it comes to performance.
- Battery is also easy and more linear to transport.
- These batteries are environmental friendly and is profitable if someone try to recycle it.

**Disadvantages**

- These batteries should not be kept in open as it is not environmental friendly and becomes toxic when it is kept in open.
- Battery is able to discharge large amount of energy, by a repeated discharge of large volumes of energy will cause the battery to degrade leading to decrease in life span of batteries.

**The Lithium Ion;** shortened to Li-ion, batteries are batteries that have been used in many different electrical appliances, ranging from mobile phones to full electrical cars. One of the important advantage is that is has very high capacity potential for a smaller size. As Li-ion battery is not introduced in hybrid vehicles but soon it will replace nickel-metal hybrid batteries.

#### 4. EMISSION GUIDELINES FOR FLEX-FUEL STRONG HYBRID VEHICLES

The Union Ministry of Road Transport and Highways issued guidelines for **Flex-Fuel Vehicles (FFV)** and **Flex-Fuel Strong Hybrid Vehicles (FFV-SHEV's)**.

- The Automatic Manufacturers in India have been asked to start manufacturing FFV and FFV-SHEV's.
- This will help in substituting India's import of petroleum as a fuel as well as provide direct benefits to farmers.
- Automobile Manufacturers have been advised to start manufacturing such vehicles in accordance with **BS-6 Norms**.

**Regulating Organizations**

- **Bharat Stage Emission Standards (BSES)**, regulates the output of pollutants from vehicles plying in the country.
- The **Central Pollution Control Board (CPCB)** which falls under Ministry of Environment, Forest and Climate change set the standards to regulate from vehicles in India.

**BS6 (BSVI) norms**

- Bharat Stage (I, II, III, IV & VI) re emission standards set by the governing body Bharat Safety Emission Standards (BSEB) to regulate the output of pollutants from vehicles plying on the road.
- The first emission standard or norm, introduced in the year 2000, was known as 'India 2000' and later, BS2 and BS3 were introduced in 2005 and 2010 respectively.
- While the first three emission norms were introduced at regular intervals, BS4 was introduced in 2017, after a gap of seven years.
- The BS6 emission standard is the sixth sense iteration of the emission norm.

TABLE 1: Emission Norms

| Fuel type                | Pollutant Gases            | BS6(BSVI) |
|--------------------------|----------------------------|-----------|
| Petrol Passenger Vehicle | Nitrogen Oxide (NOx) Limit | <60mg>    |

|                          |                               |           |
|--------------------------|-------------------------------|-----------|
| Petrol Passenger Vehicle | Particulate Matter (PM) Limit | <4.5mg/km |
| Diesel Passenger Vehicle | Nitrogen Oxide (NOx) Limit    | <80mg>    |
| Diesel Passenger Vehicle | Particulate Matter (PM) Limit | <4.5mg/km |
| Diesel Passenger Vehicle | HC + NOx                      | 170mg/km  |

## 5. CONCLUSION:

Hybrid cars are definitely more environmentally friendly than internal-combustion vehicles, Batteries are being engineered to have a long life. When the hybrid cars become more widespread, battery recycling will become economically possible. Research into other energy sources such as fuel cells and renewable fuels make the future look brighter for hybrid cars.

## REFERENCES

- [1]The social and environmental impact of hybrid cars, *Journal of Student Research* (ISSN: 22167-1907) by Dr Maria Teresa Matriano (Middle East College, Oman)
- [2]Environmental impacts of hybrid and electrical vehicles- a review, *The International Journal of Life Cycle Assessment* **17**, 997-1014 (2012) by Troy R Hawkins
- [3]Environmental impacts of hybrid, plug-in hybrid, and battery electric vehicles- what can we learn from lifecycle assessment? *The International Journal of Lifecycle Assessment* **19**, 1866-1890 (2014) by Andre Nordelof
- [4]A Lifecycle Environmental Impact Comparison between Traditional, Hybrid and Electric Vehicles in the European Context, *Sustainability* **2021**, 13, 10992 by Emiliano Pipitone, Salvatore Caltabellota and Leonardo Occhipinti
- [5]The importance of Hybrid vehicles in urban traffic in terms of environmental impact, *Archiwum Motoryzacji* **85** (3), **2019** by Branislav Sarkan, Jozef Gnap, Monika Kiktova

## IMPLEMENTATION AND EFFECTIVENESS OF SOLAR-WIND HYBRID CHARGING STATION FOR ELECTRIC VEHICLES

Shubham Anil Pandey

Student,

Department of Mechanical Engineering  
Sir M. Visvesvaraya Institute of Technology  
Bengaluru-562157

### ABSTRACT

*In today's modern world which is growing rapidly in terms of technologies but also growing environmental concerns and the rapid growth in energy demand, which is leading humans to use alternative energy for currently used conventional energy sources. As Renewable energy is obviously advantageous over conventional energy but it is not easy to handle and control as it can be solved by integrating wind and solar sources as they are proportional to each other, The growth of electric vehicles has been noticed in last few years but the charging stations are insufficient to charge vehicles fully in some period of time as by using the natural resources like solar and wind energy as we convert it into electricity which can be used as non-conventional energy to run the vehicle, as combination of solar and wind energy gives better output.*

Keywords: Hybrid vehicles, Smart charging, Wind turbine, Photovoltaic cells

**ABBREVIATIONS:** EV, CAN, PLC, OCPP, OSCP, HEV

(EV: Electric vehicle, CAN: Controller Area Network, PLC: Programmable Logic Unit)

### 1. INTRODUCTION

As fossil fuel is depleting and the effects on environment as much effective in negative way every year we move forward. As environmental sources are not sufficient to meet over demands in this present and future time, the other forms of energy can compensate the difference. As the main effect in air quality is due to vehicles emissions. As among the renewable energy wind and solar is most effective and it is never depleting as wind turbines appear to be most promising renewable source of energy. On other hand solar photovoltaic cells and solar energy are promising and effective in hot countries in South Asia. Wind system is not always possible to give energy all the time due to large flowrate of wind is not possible every time same goes for photovoltaic cells as sunlight is possible in sunny days and daytime which is limited amount of time to provide energy therefore energy storage comes here as energy is stored as per power demands. Energy banks or battery banks are expensive that's basically main con of hybrid charging, other side on pro basis the vehicles are charged while driving as here the wind turbine and photovoltaic cells provide energy all the time to battery bank therefore it charges continuously and vehicle doesn't need to be on standby.

### 2. IMPELATION OF SMART CHARGING OF EV's FROM RENEWABLE ENERGY

**SMART CHARGING:** In this case of AC charging the pulse width modulation signal (PWMS) on the control pilot of TYPE 1 and TYPE 2 AC chargers can be continuously controlled to adjust the EV charging current based on solar or wind output. For combo DC charging CAN and PLC communication can be used respectively to adjust charging power.

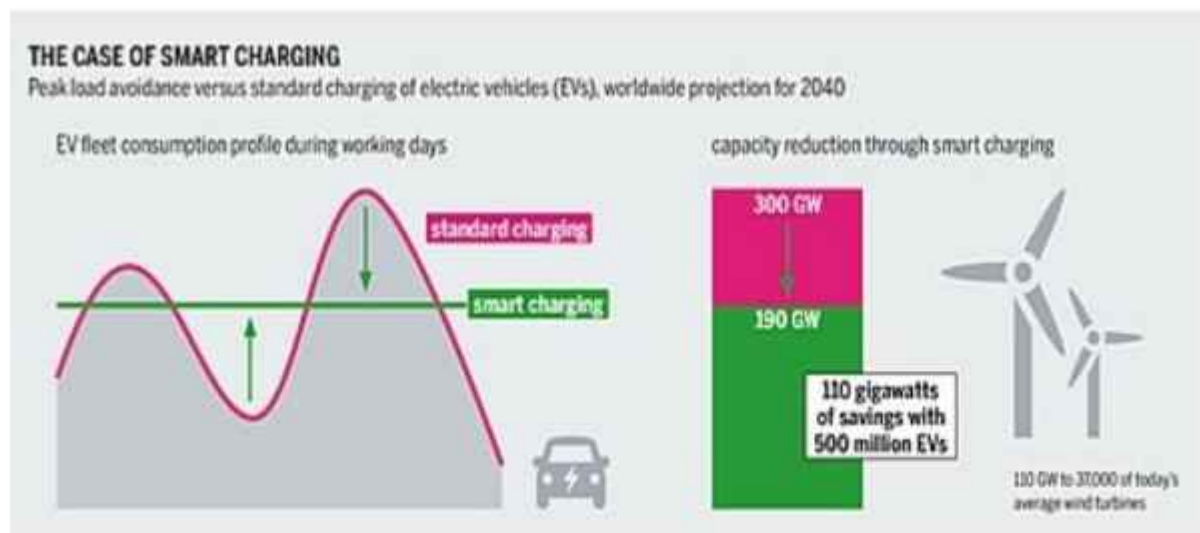

FIGURE 1. Wikipedia for smart charging

**EV CHARGING COMMUNICATIONS:** The technology powering the EV charging industry has evolved so much over the last few years. As we are witnessing a shift towards the standardization of chargers and the introduction of new industry protocols for interoperability.

Charge point operators and e-mobility service providers are facing challenges expanding internationally especially in dealing with different protocols, regulations and multi-currencies and integrating roaming capabilities in network.

1. **OPEN CHARGE POINT PROTOCOL (OCPP):** The open charge point protocol (OCPP) is an application protocol over communications between electric vehicle charging stations and a central management system. As protocol was developed by an **OPEN CHARGE ALLIANCE (OCA)** for the EV infrastructure market, and is considered infrastructure Interoperability among charging equipment manufacturers, software and system providers, charging network operators and research organizations. The protocol is a proven way to optimize the cost and minimize the risk of network infrastructure investments. It provides flexibility for infrastructure operators to EV-agnostic and allows easy access to EV drivers.
2. **OPEN CHARGE POINT INTERFACE (OCPI):** The Open charge point interface (OCPI) is designed for exchanging information about charge points between charge point operators and e-mobility service providers to enable cable and automated EV roaming as it includes
  - Provides session information including location information
  - Sending remote commands, such as reservation commands.
  - Providing charge detail records (CPRS) for billing purposes.
  - Authority charging sessions by exchanging tokens.

#### As it supports

- Charge point information
- Authority charging sessions
- Tariffs
- Reservation
- Roaming
- Handling registrations
- Smart charging

3. OPEN SMART CHARGING PROTOCOL (OSCP): OSCP is an open protocol for communications between a charge point management system and an energy management system of a site owner. The protocol can be used to communicate real time prediction of local electricity grid capacity to the charge point operator. OSCP facilitates capacity based smart charging of EV's.

### 3. CONCLUSION

- Increasing energy demand by reducing it via energy efficiency.
- New technologies developments that minimizes waste, lower the level of air pollution caused by fossil fuel powered combustion engine.
- More efficient than combustion engine.
- Energy storage exist and less amount of time needed to charge.
- Moving towards the future and new technologies for the human wellness on air pollution it is very reliable option to opt for.

### REFERENCES

- [1]Smart charging solutions for HYBRID & ELECTRIC VEHICLES – Sulabh Sachan, Sanjeevkumar Padmanaban, Sanchuri Deb.
- [2]Technologies & Applications for Smart Charging of Electric and Plug-in Hybrid Vehicles. - Ottorino Vaneri.
- [3]Electric and Hybrid Vehicles – Tom Denton
- [4]Feasibility of Grid-connected Solar-wind Hybrid System with electrical vehicle charging station, Journal of Modern Power Systems, Volume-9, Issue 2 by Prachi Chauhan, Shakti Singh, Nirbhaw Jap Singh
- [5]Sizing of solar-wind hybrid electrical vehicle charging station by using HOMER software, Journal of Cleaner Production, Volume 279, Jan 2021, 123615 by Orhan Ekren
- [6]Solar and wind powered Hybrid energy vehicle, August 2017 IJSDR, Volume-2, Issue 8 by Dr Vidhya H.A, Kushaal H.N, Giridhar R, Pawan Kumar H, Santosh K

## OVERVIEW OF SOLAR POWER SYSTEMS

Shubham Anil Pandey<sup>1</sup>, Janardhana K<sup>2</sup>

<sup>1</sup>Student, <sup>2</sup>Associate Professor  
Department of Mechanical Engineering  
Sir M. Visvesvaraya Institute of Technology  
Bengaluru-562157

### ABSTRACT

*Energy is very important variable that its conservation is of primary interest to present and future engineers. As we know that law of conservation of energy states that energy can neither be created or destroyed, but it can be transformed from one form to another. This helps in sustainable use and protection of natural resources. This research work on power generation from solar source is a system that assists in this energy transformation and storage to produce electricity. As the quest for obtaining this source of energy from different mean is in high demand, as solar energy is one them, it is one of the sources that is harnessed today to provide electricity. As in this research paper we will be discussing about the overview of solar power system its components, pro's and con's etc.*

**Keywords:** Electricity, Energy, PV cells, MPPT, Battery.

### 1. INTRODUCTION

Solar power is energy from the sun that is converted into thermal or electrical energy. Solar energy is the cleanest and most abundant renewable energy source available, the energy is captured with primarily with solar panels. Each particle of sunlight (photon) that reaches earth contains energy that fuels our planet. Solar energy is ultimate source responsible for our weather systems and energy sources on earth and enough solar radiation hits the surface of the planet each hour to theoretically fill our global energy needs for nearly an entire year. The "Photovoltaic effect" is the mechanism by which silicon solar panels harness the suns energy and generate electricity. As we can say by general description of solar power systems is that the energy is free and unlimited and more importantly its clean, renewable energy source.

### 2. OVERVIEW OF THE RESEARCH

Solar energy is renewable energy resource and is converted to electrical energy in two ways thus using "photovoltaic material" which generates an electrical potential when exposed to light or using thermal process which uses the energy from the sun to heat working fluid in an electricity cycle, it is known fact that heat energy from the sun is quantized in photon; this photon in sunlight hit solar panel and is absorbed by semi-conducting materials such as silicon. Electrons (negatively charged) are knocked loose from their atoms, allowing them to flow through the material to produce electricity. The complimentary position charges that are also created (like bubbles) are called holes and flow in direction opposite of the electrons in silicon panel. By this process the photovoltaic cell converts the energy into visible amount of DC (Direct current) electricity. Since this energy is required for further use as it is temporarily stored in accumulator (battery) from where it fed into an inverter circuit which turns DC electricity into 220-240V AC (Alternating current) needed in homes to drive or use of electronic gadgets like computers, Televisions etc.

### 3. RESEARCH METHODOLOGY

- **Solar Orientation:** - Solar orientation is the positioning of a site, building or space relation to cardinal directions and more importantly the suns path. Whether it's your site, house or your room, everything has special orientation and relationship to the suns movement across the sky. Solar orientation is very useful for designing the solar power system and utilizing the maximum solar radiation from the sun.

**STEP 1:** - Considering Bengaluru city having latitude =  $12.97^\circ$

**STEP 2:** - Subtract your city latitude from  $90^\circ$  to EQUINOX  
 $90^\circ - 12.97^\circ = 77.03^\circ$

**STEP 3:** - Sum angle at summer SOLSTICE= EQUINOX +  $23.5^\circ$

Therefore, summer SOLSTICE is  $77.03^\circ + 23.05^\circ = 100.53^\circ$

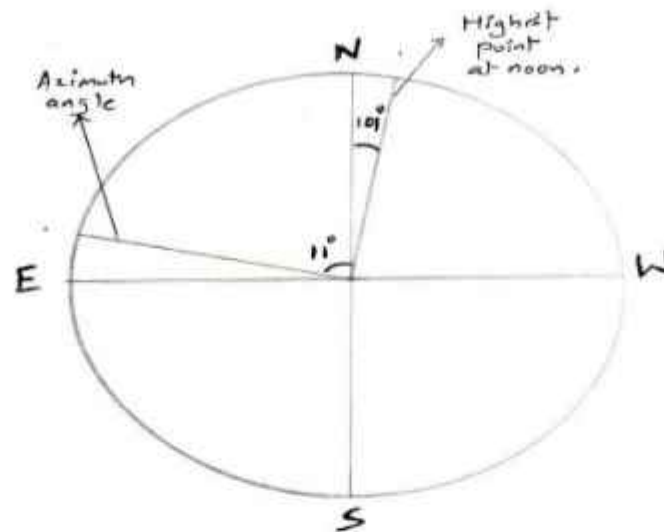

FIGURE 1: Solar angle

In Bengaluru Summer solstice the sun will rise from south-east at  $11^\circ$  which is called azimuth angle. As sun will reach its maximum angle at  $101^\circ$  from north-west at noon.

STEP 4: - Sum angle at winter SOLSTICE = EQUINOX -  $23.5^\circ$

Therefore  $77.03^\circ - 23.05^\circ = 53.53^\circ$

Here, in Bengaluru at winter solstice the sun will rise from south-east at  $36^\circ$  which is called as azimuth angle, as sun will reach its maximum angle at  $54^\circ$  from north-west.

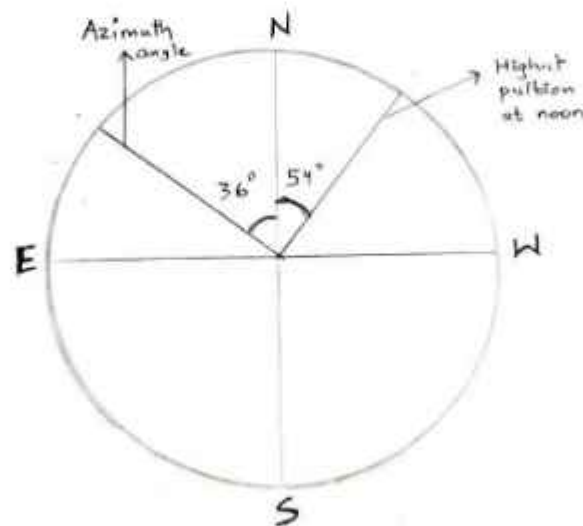

FIGURE 2. Solar azimuth angle

- **Peak power point (max power) in solar cell**

Solar cell energy conversion efficiency is percentage of solar power converted from absorbed light to electrical energy and collected, when solar cell is connected to electrical current



$$n = \frac{P_m}{E \times A_c} \quad n = \text{efficiency, } P_m = \text{Maximum power, } E = \text{Irradiance } \text{w/m}^2$$

$$A_c = \text{Surface area } \text{m}^2$$

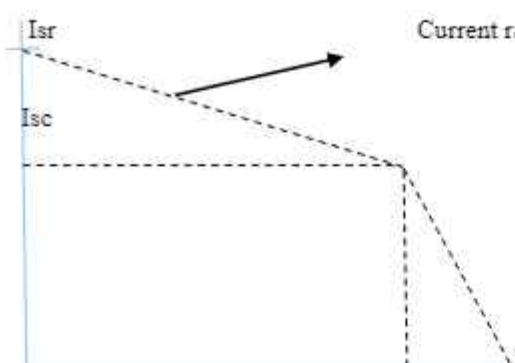

$$\text{Fill factor} = \frac{I_{mp} \times V_{mp}}{I_{sc} \times V_{oc}}$$

$$P_m = \text{Fill factor} \times I_{sc} \times V_{oc}$$

#### 4. CONCLUSION

Solar energy is a clean, pollution free and renewable source of energy. Development of this source of energy requires an accurate detailed long-term knowledge of the potential taking into account seasonal variations. The region of the earth between the latitudes of 40°N and 40°S is generally known as solar belt and this region is supposed to be with an abundant amount of solar radiation. Karnataka receives global solar radiation in the range of 3.8-6.4 kWh/m<sup>2</sup>. Global solar radiation during monsoon is less compared to summer and winter because of the dense cloud cover. The study identifies that coastal parts of Karnataka with the higher global solar radiation are ideally suited for harvesting solar energy.

#### REFERENCES

- [1] Arjyadhara Pradhan, Dr.S.M. Ali and Puspapriya Behera, 2012 Utilization of battery bank in case of solar PV system and classification of various storage batteries, International Journal of scientific and research publications, 2(2012)22250-3153.
- [2] Chetan Singh Solanki. 2011, Solar Photovoltaics Fundamentals, Technologies and Applications, PHI Learning Private Limited, New Delhi.
- [3] K.C Divya and Jacob Ostergaard. 2009. Battery energy storage technology for power systems- An overview of Electrical Power System Research, 79 (2009) 511-520.
- [4] Surface albedo and reflectance; Review of definitions, angular and spectral effects; and intercomposition of major data sources in support of advanced solar irradiance modelling over the Americas by Christian A Gueymard, Vincete Lara-Fanego, Manajit Sengupta and Yu Xie.

## FIBER REINFORCED COMPOSITES- A REVIEW

Pradyumna G<sup>1</sup>, Sumukha T V<sup>1</sup>, Shrivarshini G M<sup>1</sup>, Varun M<sup>1</sup>, Umashankar.M<sup>2</sup>

<sup>1</sup>Students, <sup>2</sup>Professor and Head  
Department Of Mechanical Engineering  
K.S Institute of Technology (KSIT), Bengaluru, India

### ABSTRACT

*A hybrid composite material is one that is made up of two or more constituent fibres. materials have chemical or physical properties that are noticeably diverse, and they are combined to form a material with qualities that are distinct from the separate constituents. Composites have been discovered to be the most promising and discriminating material available in the twenty-first century. Composites reinforced with fibres of synthetic or natural materials are becoming more popular as the market grows in demand for lightweight materials with high strength for specific applications. Not only does fiber-reinforced polymer composite have a high strength-to-weight ratio, but it also has exceptional properties such as high durability, stiffness, damping property, flexural strength, and resistance to corrosion, wear, impact, and fire. Metal matrix composites (MMCs), ceramic matrix composites (CMCs), carbon/carbon composites (C/C), and polymer matrix composites (PMCs) or polymeric composites are the four types of fibre reinforced composites. Synthetic fibres (in British English; see spelling variations) are fibres created by humans through chemical synthesis.*

**Keywords:** Types of Synthetic Fibers-Rayon,Nylon,Polyester,Acrylic.

### 1. INTRODUCTION

#### 1.1 Synthetic fibres

Man-made fibres made from chemical substances that are used to make clothing and other useful items. Polymerization is used to create these. Synthetic fibres can be fully synthetic or semi-synthetic. Chemicals are used to make purely synthetic fibres such as nylons, polyesters, and acrylics, whereas natural polymers are used to make semisynthetic fibres such as rayons. Synthetic fibres are formed by extruding fiber-forming materials through spinnerets.



FIGURE 1. Synthetic fiber

#### Types of Synthetic fibres-

- Rayon Fibres –

Rayon possesses qualities that are akin to silk. It is a man-made fibre that is less expensive than silk. It's made from wood pulp.

- Nylon fibres -

These fibres are created from water, coal, and air and are strong, light, glossy, and easy to wash. The fibre is entirely synthetic and far more durable than steel wire.

#### 1.2 Natural fibres

Fibres produced by geological processes or from the bodies of plants or animals. They can be used as a component of composite materials, where the fibre orientation influences the properties. Natural fibres can also be matted to create sheets of paper or felt. Natural fibres have been used for textile materials since before recorded history. The

discovery of flax and wool fabrics at excavation sites of Swiss lake dwellers is likely the oldest indication of fibre use (7th and 6th centuries BCE). Prehistoric peoples also used a variety of vegetable fibres.



FIGURE 2. Natural fibre

#### Types of Natural fibres-

- Wool: Wool is a natural textile fibre obtained from sheep, goats and camels. It traps a lot of air. Air is a bad conductor of heat. This makes clothes made from wool useful in winter.
- Silk: Silk is also a natural textile fibre which is obtained from silkworms. The rearing of silkworm to obtain silk is known as sericulture.
- Cotton: It is one of the plant fibres that are used to make clothes. It is a soft staple fibre that is found as a boll around the seeds in a cotton plant.
- Jute: It is a vegetable fibre that is soft, shiny and is spun into coarse strong threads. Jute fibres are totally biodegradable and recyclable materials, i.e., environmentally friendly materials.
- Basalt fibre is a dark-coloured, fine-grained solidified volcanic rock. It is primarily composed of Silicone Dioxide ( $\text{SiO}_2$ ), Aluminium Oxide ( $\text{Al}_2\text{O}_3$ ), Iron Oxide ( $\text{FeO}+\text{Fe}_2\text{O}_3$ ), Calcium Oxide ( $\text{CaO}$ ), Magnesium Oxide ( $\text{MgO}$ ), and Sodium Oxide. Basalt is a natural material that is friendly to the environment. It is used in the production of basalt fibres.

### 1.3 Fiberglass

Fiberglass is a common type of glass fibre-reinforced plastic. The fibres can be arranged randomly, flattened into a sheet known as a chopped strand mat, or woven into glass cloth. The plastic matrix can be a thermoset polymer matrix (typically based on thermosetting polymers like epoxy, polyester resin, or vinyl ester resin) or a thermoplastic matrix.



FIGURE 3. Fiberglass

#### 1.3.1 Types of Fiberglass

- A-glass is also known as alkali glass or soda-lime glass. It is the most commonly available type of fiberglass. About 90% of the glass that is manufactured is alkali glass. It is the most prevalent type that is used in making glass containers like jars and bottles for food and beverages, and windowpanes.
- C-glass, also known as chemical glass, has the highest chemical resistance. It maintains structural balance in corrosive environments.

- E-glass is also known as electrical glass. It is a lightweight composite material that has applications in aerospace, marine, and industrial settings. E-glass fibreglass cloth is an industry standard that offers a good mix of performance and cost. It has an excellent draping characteristic that makes it easier to work with.

## EPOXY RESIN

The family of basic components or cured end products of epoxy resins is known as epoxy. It's well-known for its strong adhesive properties, making it a useful product in a variety of industries. It is heat and chemical resistant, making it an excellent choice for anyone who requires a solid hold under pressure. Epoxy resin is a long-lasting compound that can be used on a variety of surfaces, including wood, fibres, glass, and metal.

## 2. MATERIALS AND METHODOLOGY

### 2.1 COMPONENTS

Hybrid composites are materials made up of two or more types of fibres embedded in a single polymer matrix. Hybrid composite materials are increasingly being used in a wide range of engineering applications due to their improved properties and numerous advantages over traditional composite materials.

#### I. BASALT FIBER:

Basalt fibres have higher strength and elastic modulus than standard E glass and are comparable to special high strength S glass and carbon fibres. As a result, they provide car manufacturers with the opportunity to significantly reduce the cost of SMC/BMC parts while maintaining high strength and stiffness. Basalt fibres have the same dielectric properties as glass fibres. Furthermore, switching from glass to basalt has no effect on radar transparency.



FIGURE 2. Basalt Fiber

#### II. JUTE FIBER:

Jute fibre is completely biodegradable and recyclable, making it environmentally friendly. It has high tensile strength, low extensibility and ensures better breathability of fabrics. Jute has good insulating and antistatic properties, as well as low thermal conductivity and a moderate moisture regain. Jute also has acoustic insulating properties and is manufactured without causing skin irritations. Jute can be blended with other fibres, both synthetic and natural.



FIGURE 3. Jute Fibre

### III. EPOXY:

Lapox L12 is a liquid, unmodified epoxy resin with a medium viscosity that can be used to make glassfiber reinforced composites with a variety of hardeners. The hardener used is determined by the processing method and the properties required of the cured composite. Hardener K6 is a room temperature curing liquid hardener with a low viscosity. It is frequently used for hand lay up applications. Because it is highly reactive, it has a short pot life and a rapid cure at normal ambient temperatures. Laminates can withstand operating temperatures of 1000 C.



FIGURE 4. Lapox L-12 With K-6 Hardener

## 2.2 METHODOLOGY

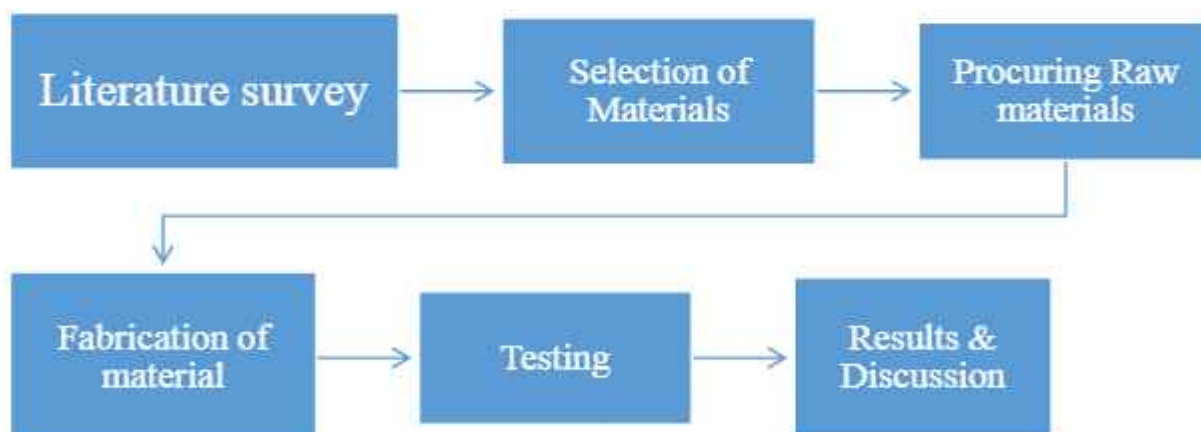

### 2.2.1 HAND LAYUP TECHNIQUE

The hand lay-up method is a composite material moulding technique in which the final product is created by overlapping a certain number of different layers.

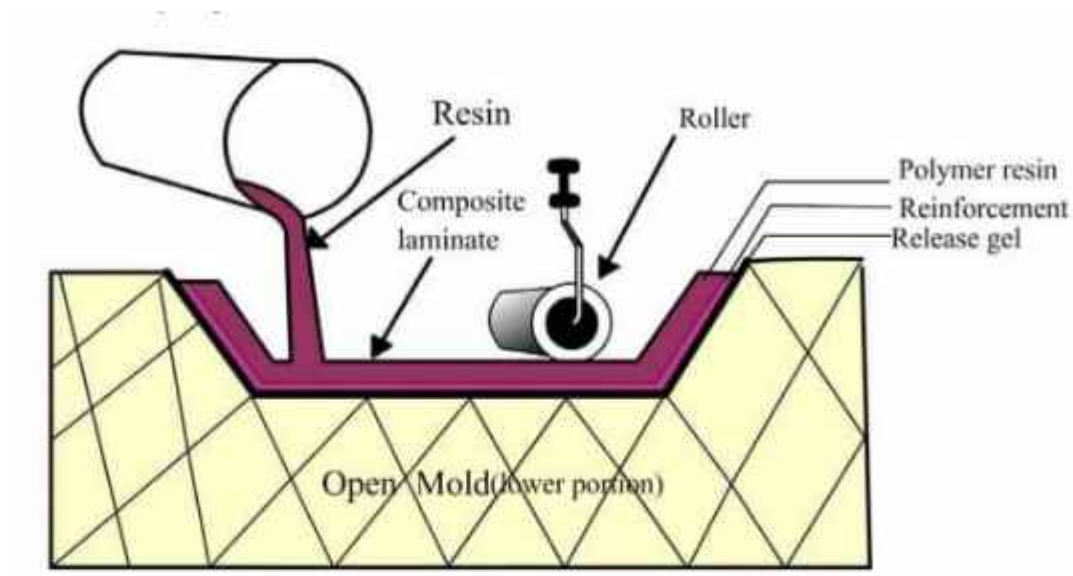

FIGURE 5. Hand layup Technique



FIGURE 6. Specimen After Fabrication

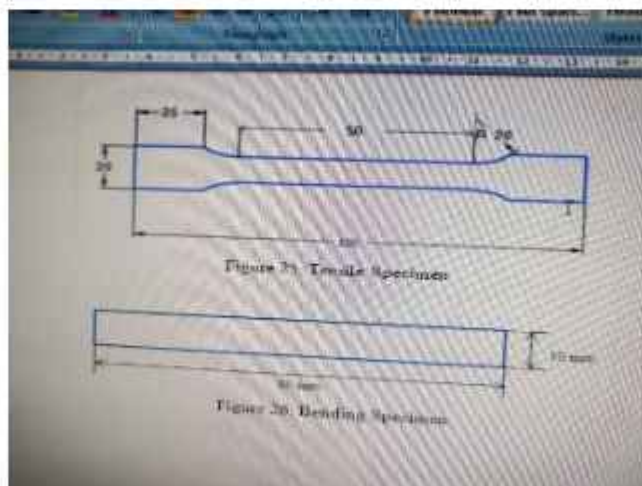

FIGURE 8. Dimensions of Testing Material



FIGURE 9. Material being testing

## CONCLUSIONS

Procured a Vitrified tile in order to get a smooth surface finish and to support our composite material.

On the tile, a plastic sheet on which we carried out the hand layup technique to get a glossy surface finish and to easily remove the material once it completely dries.

Spread a layer of epoxy mixed with hardener on the plastic sheet and placed a layer of basalt fiber and on which again a layer a epoxy was used to place jute, this process was repeated till we achieved the required thickness

## ACKNOWLEDGEMENT

The authors would like to thank Dr.Umashankar M, Professor And Head of Department of Mechanical Engineering and Dr. Girish TR, Associate Professor Department of Mechanical Engineering K.S Institute of Technology for supporting these research activities.

## REFERENCES

- [1] Properties and Applications of Basalt Fibre and Its Composites- Zongwen Li1, Jianxun Ma, Hongmin Ma1, Xin Xu1 School of Human Settlements and Civil Engineering, Xi'an Jiaotong University, Xi'an, Shaanxi 710049, China.
- [2] Comparative study of effect of Basalt, Glass and Steel Fibre on compressive strength-Ranjitsinh K. Patil, D. B. Kulkarni
- [3] Basalt Fibers and its composites -Krishna Pareek, Dr. Purnachandra Saha.
- [4] Basalt Fiber as a reinforcement of polymer composites - Tibor CZIGÁNY, János VAD and Kornél PÓLÓSKÉI.Department of Polymer Engineering, Faculty of Mechanical Engineering, Budapest University of Technology and Economics.
- [5] Synthesis and research of epoxy resin toughening agent- Hongming Ma, Nannan Hu, Cheng Wu, Yinfeng Zhu, Yi Cao and Qing Qing Chen4.

## FABRICATION OF SONAR GLASSES FOR VISUALLY IMPAIRED

Darshan G<sup>1</sup>, <sup>2</sup>Harish B<sup>1</sup>, K Jeevan Kumar<sup>1</sup>, Manoj A<sup>1</sup>, Rajesh G L<sup>2</sup>

<sup>1</sup>UG Students, <sup>2</sup>Assistant Professor

Department of Mechanical Engineering,

K.S. Institute of Technology Bangalore- 560109

### ABSTRACT

*Blind mobility is one of the major challenges encountered by visually impaired persons in their daily lives. Their life and activities are greatly restricted by loss of eyesight. They normally travel using blind navigation system or by their accumulated memories in their long term exploration. The main objective of the present work is to develop a low cost, reliable, portable, user friendly, low power and robust solution for smooth navigation. This paper (Smart Glasses for Blind People), as meant are the glasses are for visually impaired people. It has an in-built sensor in it which spreads ultrasonic waves in the direction the person is going by scanning at most 30 cm range. As soon as the obstacle is detected, the sensor detects it and vibrates.*

**Keywords:** Smart Glasses, Ultrasonic Sensors, Blind People.

### 1. INTRODUCTION

In this protocol, when we find objects in distance greater than 30cm then it will not sense, if the distance less than 30 cm then it will sense and create vibrations<sup>[1]</sup>. The same approach is also used in many applications. One is giving blind people the great accessibility to their environment is the objective of the smart glass system<sup>[2]</sup>. The key function of the another system is to enable the user in perceiving social signals during a natural dyadic conversation. Project's main goals are to improve navigation wearable system based on visual markers recognition and ultrasonic obstacles perception used as an vibrator assistance for blind people<sup>[3]</sup>. There was a solution for the blind people to walk safely by detecting obstacle and generating corresponding alert signal according to the distance of the obstacle<sup>[4]</sup>.

#### A Proposed Model

Blind as a special group in society, the needs of society to give them more care and attention, so that they are better able to live independently. However, how safe walking blind life is the biggest problem. Traditional navigation device mostly blind cane, blind by tapping the ground or walking around the object to determine the direction, the structure is simple, single function, easy to use, but the secondary effect is not very .blind such as poor road conditions, uneven, hanging in front of obstacles, can not be proven accurate, such a serious impact on the safety of blind travelers. A smart ultrasonic glasses for blind people comprises of a pair of wearable glasses, ultrasonic sensors for detection of obstacles in the way of blind man, a vibrator to give the vibrations as per the direction of the obstacle from the man, a central processing unit comprising of Arduino Nano which takes the information from the sensor about the obstacle distance and processes the information according to the coding done and sends the output through the vibrator, power supply is given to the central unit which distributes the power to different components. The sensor is mounted in between of the top bar, right and left and bridge present in optical glasses as shown in the figure 8. All the components are connected to the central unit using wires and the power is given from battery .

The best sensors that can be used will be ultrasonic sensors because ultrasound is a strong point, the energy consumption of slow wave propagating in the medium relatively far distance. Therefore often it is used to measure the distance over big length. At the same time, ultrasound for the object in the dark, dust, smoke, electromagnetic interference, toxic and other harsh environments have a certain ability to adapt, with a wide range of applications. The ultrasonic sensor is fixed at a perpendicular from the glasses. As the blind man goes closer to the obstacle the distance sent by the sensors to the central unit will decrease. Hence the vibrator will take shorter intervals and hence the vibration will be faster. But as the man will go far away the vibrations will take long intervals and hence decrease. These smart glasses are very easy to use and very simple to understand. If a blind uses it for 2-3 times then he/she will understand the working and can handle it easily<sup>[3]</sup>.

### 2. MATERIALS AND METHODS

#### 2.1 MATERIALS

For this project we have used the following components.



1. Arduino Uno.
2. Ultrasonic Sensor.
3. Vibration Motor.
4. Power supply.
5. Battery.
6. Spectacles .

The main component of this project is Arduino Uno, Ultrasonic sensor and Vibration motor.

The specification and purpose of each components are described below.

### 2.1.1. Arduino Uno

The Arduino is a open-source board based on the Microchip ATmega328P microcontroller and developed by Arduino.cc. The board is equipped with sets of digital and analog input/output (I/O) pins that may be interfaced to various expansion boards (shields) and other circuits. The board has 14 digital I/O pins (six capable of PWM output), 6 analog I/O pins, and is programmable with the Arduino IDE (Integrated Development Environment), via a type B USB cable. It can be powered by the USB cable or by an external 9-volt battery, though it accepts voltages between 7 and 20 volts. It is similar to the Arduino Nano and Leonardo.



FIGURE 1: Arduino Uno

### 2.1.2. Ultrasonic Sensor

Ultrasonic sensors are devices that generate or sense ultrasound energy. They can be divided into three broad categories: transmitters, receivers and transceivers. Transmitters convert electrical signals into ultrasound, receivers convert ultrasound into electrical signals, and transceivers can both transmit and receive ultrasound.



FIGURE 2: Ultrasonic sensor

### 2.1.3. Vibration Motor

Vibration motor is a DC motor in a compact size that is used to inform the users by vibrating on receiving signals. It has no sound. Mainly they are used in mobile phones, joysticks, pager and so on.



FIGURE 3: Vibration Motor

### 2.1.4. Power Supply

A power supply is an electrical device that supplies electric power to an electrical load. The main purpose of a power supply is to convert electric current from a source to the correct voltage, current, and frequency to power the load. As a result, power supplies are sometimes referred to as electric power converters.



FIGURE 4: Power Supply

### 2.1.5. Battery

An electric battery is a source of electric power consisting of one or more electrochemical cells with external connections for powering electrical devices.



FIGURE 5: Battery

### 2.1.6. Spectacles

A wearable glass and all the components and wirings are attached on the glass.



FIGURE 6: Spectacles

## 2.2 SOFTWARE REQUIREMENTS

1. Arduino Ide.
2. Embedded.

## 2.3 METHODS

This smart ultrasonic glasses for blind people comprise of a pair of wearable glasses, ultrasonic sensors for detection of obstacles in the way of blind man, a vibrator to give the sound as per the direction of the obstacle from the man.

The best sensors that can be used will be ultrasonic sensors. Often it is used to measure the distance over big length. At the same time, ultrasound for the object in the dark, dust, smoke, electromagnetic interference, toxic and other harsh environment have a certain ability to adapt, with a wide range of applications.

The working of this device is quite simple, if an object is detected to the right, the right frame of the specs will vibrate. And vice versa. If object is detected to the center, both the frames will vibrate.



FIGURE 7: Algorithm

### 3. RESULTS AND DISCUSSION

The performance of the proposed system has found to be effective. The ultrasonic sensors can detect the obstacle and alert the user with a vibration. The proposed model is easy to wear and use and can be used as a portable model for visually impaired people.



FIGURE 8: Finished Model

### 4. CONCLUSION

The objective of this project is Third Eye for the Blind is to design a product which is very much useful to those people who are visually impaired and those who often have to rely on others. It is an innovation which helps the blind person to move around and go from one place to another with speed and confidence by knowing the nearby obstacles using the help of the wearable band which produces the ultrasonic waves which notify them with buzz sound or vibrations. It allows the user those who are visually impaired to walk freely by detecting the obstacles. They only need to wear this device as a band or cloth on their body.

### 6. REFERENCES

- [1]. "Obstacle Detection for Visually Impaired" by Ayush Wattal , In 2002, a group at Oxford developed a device that produced AR vision for people with severe peripheral vision loss.
- [2]. "A lightweight device to help visually impaired people", by a group of research from Munich, Mobile Computing Applications and Services (MobiCASE), 6th International Conference, 2015.
- [3]. "Smart Visibility Glasses for the Blind ", by Amogh Rane, Siddhesh Pujari, Gandhar Khopkar, Azhar Khan, Jyoti Dange in Electronics Components and Technology Conference (ECTC), 2016 IEEE 66th , 2016.
- [4]. " A lightweight device to help visually impaired people" By Alessandro Bissacco, Mark Cummins, Yuval Netzer and Hartmut Neven in Industrial Electronics (ISIE), 2013 IEEE International Symposium, 2013.
- [5]. "A new computer vision-based system", A group of researchers from Switzerland to help rollator users in 2014.
- [6]. "An alternative mobility aid for the blind :the ultrasonic cane", T.O.Hoydal, J.A.Zelano", in Bioengineering Conference Proceedings of the 1991 IEEE Seventeenth Annual NorthEast, 1991.

## DESIGN AND FABRICATION OF FINGER MILLET CUTTING MACHINE- A REVIEW

Akash H S<sup>1</sup>, Anand S<sup>1</sup>, Dhanush K<sup>1</sup>, Sanjay P<sup>1</sup>, Harish U<sup>2</sup>

<sup>1</sup>Students, <sup>2</sup>Assistant Professor  
Department of Mechanical Engineering  
K.S. Institute of Technology Bangalore -560109

### ABSTRACT

*This project addresses a crop cutting machine, which is fabricated with very simple mechanisms at low cost. Basically the Problems faced by farmers, who work on small fields, while harvesting is that, the crop takes a lot of time, the availability of labor and their cost during cutting season is also very high. Although various agricultural machines are available in the market but they are quite large and costly. It becomes uneconomical for small farmers to afford such kind of machines. In order to overcome the situation, we have introduced a new simple machine that is more efficient for small farmers. The design and working of a simple ragi cutting machine is discussed here, which is operated on the principle of slider crank mechanism by varying the length of cutting grains. And especially the machine targets the farmers who have land area of less than 2 acres. Hence this project might be the solution to the problems faced by a small scale farmer regarding cost and labor implementation.*

**Keywords:** Cutting Blades, Slider-Crank Mechanism, Dc Gear Motor, Battery

### 1. INTRODUCTION

Agriculture is the science and art of farming, including cultivating the soil, producing crops and raising livestock. Ragi is also known by the name finger millet. It is an important small millet food and fodder crop which is extensively cultivated in Asian countries like India, Malaysia, China and Nepal. In India finger millet is cultivated over an area of 1.19 million hectares with a production of 1.98 million ton giving an average productivity of 1661 kg per ha.

Harvesting is the process of gathering a crop. In ragi, harvesting refers to the cutting and gathering of earheads along the stalks. When the earheads turn brown color or at maturity stage, cut the earheads alone or cut the stalk along with ear heads by using sickles. The earheads are heaped in sun on the threshing floor for 1-4 days for drying, and then machine winnows and cleans the Ragi after threshing. The crop cutting is an important stage in agriculture field, over many years, agricultural practices have been carried out by smallholders cultivating between 1 to 2 hectare, using human labor and traditional tools such as wooden plough, yoke, leveler, harrow, mallet, spade, big sickle etc. Here we design and analyze the crop cutting machine which is to help the Indian farmer especially to small farm. It will reduce the cost of crop cutting in field. This machine cuts earheads separately and stores it. Due to this, farmer can feed straw to the domestic animal easily without any heavy efforts more over it is simple in design. It will help to increase the economical standard in Indian farmer.

### 2. COMPONENTS

#### 2.1 D C MOTOR



A DC motor is any of a class of rotary electrical motors that converts direct current electrical energy into mechanical energy.

## 2.2 BATTERY

Batteries convert chemical energy directly to electrical energy and stores it.



## 2.3 CUTTER BLADES

The pair of two cutters is used for cutting. One blade is stationary and the other is reciprocating. The thickness of blade is 2 mm and made up of MS plate.



## 2.4 BLOWER

Blower is a machine whose primary function is to provide and accommodate a large flow of air to various parts intern which will direct the flow by means of air by using this method the finger millet will be collected in collector this is achieved by rotating a number of blades connected to a hub a driven by a motor.



### 3. WORKING PRINCIPLE

For the motion of cutting mechanism of blades a simple "Slider-Crank Mechanism" is employed which has fixed blade, movable blade, rotating disk, rocker arm and coupler in which the fixed blade and moving blade has prismatic joint, coupler and rocker-

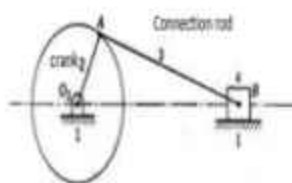

arm has revolute joint, the coupler and rotating disk has revolute joint and the rocker and moving blade has fixed joint. This mechanism is used to convert rotary motion into the reciprocating motion. This can be achieved by mounting the coupler off set from the center of rotating disk as shown in the Fig. In the the circle represents a rotating disk of thickness "t", radius "r" and "cs" represents the length of the coupler positioned off sated in rotating disk at a distance "r". When the coupler and the dotted line indicating distance "r" gets collinear at one end the minimum stroke and in the other end maximum stroke is achieved and thus the displacement "S" takes place For this mechanism, the power for driving the cutting mechanism, is transmitted from the motor with the help of the shaft which is connects motor and coupler. The motor which is running at a 60rpm, which gives rotary motion to coupler and then converted to linear motion, this motor is driven with electric battery of 6V

### 4. RESULTS AND DISCUSSION

For plot 1, since the plot was dense, it was difficult to cut. Supplied power was not sufficient to cut those dense areas. Also the efficiency of machine was poor. For plot 2, since plot was not dense but was inclined, it was comparatively easy to cut. Due to inclined nature of crops, machine pushed the crops so all crops were not cut properly which leads to decrease in efficiency of machine. But performance was comparatively better than that for plot 1. For plot 3, crops were straight. It was easy to cut lower part. In this plot we were also able to test upper cutter. With the motion of wheel, drum rotated and grabbed upper part of crops and cutter cut the lower portion While testing in all three plot, we also found that comparatively more power was required to push the machine which was due to the direct connection of wheel shaft with drum shaft by chain sprocket

### 5. CONCLUSION

The design and fabrication of finger millet cutting machine with selected constraints is completed successfully. The farmers can use this machine with upgraded cutter mechanisms that includead justing the height of the cutter for their desired level. This system is fabricated at the lower cost, which is approximately 60% less than the market value. This machine is operated manually using power source and hence maintenance is minimized, mean while the service can also be achieved easily and this can give a huge advantage to this equipment

### REFERENCE

- [1] Donny T ,Prabhakar P, Upadhyay C, CherianRandSureshAM(2012), Development of Working Prototype for Ragi Harvesting and Threshing Operation. International Journal of Scientific and Engineering Research.
- [2] Chowde Gowda M, Sreenatha A, Ramya H.N. and Jaymala G.B. ,2010. "Estimation of Energy Requirement for finger millet(EleusineG). Cultivation in Karnataka(India)". International Journal of Applied Agricultural Research.
- [3] Dr.Shailaja Hittalmani, "Development of high yielding, disease resistant, drought tolerant Fingermillet", University of Agricultural sciences, GKVK, Bangalore-560065, India, shailajah\_maslab @ rediffmail.com
- [4] A. Sreenatha, "Finger millet Harvesting and Threshing in Karnataka. A Case Study", Research Associate, Division of Agricultural Engineering, UAS, GKVK, Bangalore-560065, Karnataka, India.
- [5] Ojha T.P and Devnani 1987, Status of harvesting machinery in India-a country report, "Regional workshop on Design and Development of harvesting and Threshing Equipment", IARI, NewDelhi.
- [6] Chandrakantappa Kammar, Batagurki.S.B and Krishnappa.N, 2001, "Effect of Different Threshing methods on mechanical Damage and germination of finger millet".

## SOLAR POWERED AQUAPONICS SYSTEM

Chiranjeevi U<sup>1</sup>, Giridhar M P<sup>1</sup>, Prabhudev CM<sup>1</sup>, Manjunath B R<sup>2</sup>

<sup>1</sup> Students, <sup>2</sup> Associate Prof

Department of Mechanical Engineering  
K.S. Institute of Technology Bangalore -560109

### ABSTRACT

*The most prevailing issues of the modern world are food and water crises. It is neither possible to consume the pesticide affected food nor grow one's own plants, due to scarcity of water and land. Under such conditions, there arises a need for a portable agricultural system which uses less water, space and is purely organic. One such solution is a small scale aquaponic system. This system is made by introducing an automation and data acquisition system; thereby there is no need for setting aside extra time for system care. This paper has used the data acquired from an existing aquaponic system to design and implement an effective small scale sustainable aquaponic system. This can lead to cost effective, sustainable ways of organic farming independent of the need for comparable land space requirement.*

**Keywords:** Portable agricultural system, aquaponics, automation and data acquisition.

### 1. INTRODUCTION

The following paper contains the methodology to build a small scale aquaponic system suitable for different economic strata of the society especially focusing on the urban population where there is evident space and time constraints. This method contributes to one aspect of sustainable household development. In a small scale Aquaponic system, organic vegetables are cultivated in a limited space by recirculating water from a fish tank, rich in nutrients which are essential for the plant growth. Out of all the available water resources on planet Earth, 2.5% is freshwater resource. In this 2.5%, only 0.3% is the readily available freshwater resource accessible to humans. 70% of this limited amount of freshwater available is used for agriculture. Water scarcity already affects almost every continent and more than 40 percent of the people on our planet. By 2025, 1.8 billion people will be living in countries or regions with absolute water scarcity and two-thirds of the world's population would be living under water stressed conditions. In 2030, 47% of world population will be living in areas of high water stress. Most population growth will occur in developing countries, mainly in regions that are already experiencing water stress and in areas with limited access to safe drinking water and adequate sanitation facilities. Most of our food requires 100s of liters of water for production and adequate of per crop area for cultivation. The daily drinking water requirement per person is 2-4 liters, but it takes 2000 to 5000 liters of water to produce one person's daily food. In such a situation, a method like aquaponics which is the combination of hydroponics and aquaculture, can contribute effectively to the problem by lowering the amount of water usage for cultivation by 80% and also 75% of the area requirement.

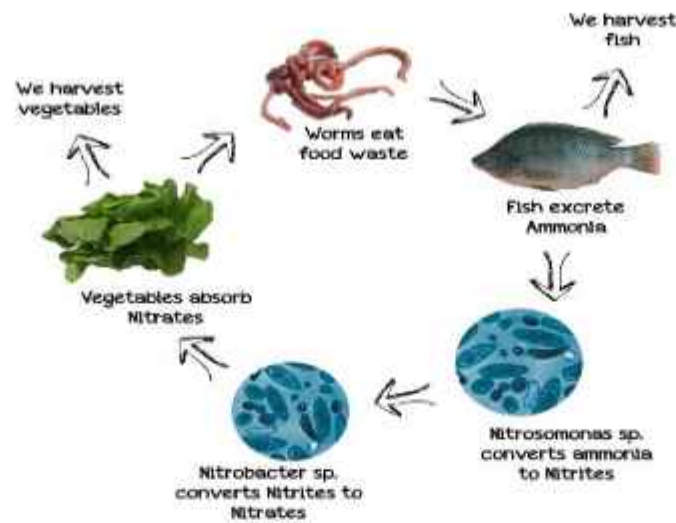

2.

one method  
production

- The two-in-effluents water filter
- Aquatic remains or natural waste matters of the fish raise in a fish tank.
- These effluents make the tank water develop toxicity which could be harmful to the fish therein, but these are nutrients vital to the growth of the plants in the aquaponic system.
- Hence, the system calls for a component that would remove the effluents and pump out the water into the grow bed for plants.
- Thus one of the major advantage of aquaponics is use of less water and spaces; producing less water waste and pollutants when compared to conventional method and using semi-skilled and local labour thus contributing to a sustainable livelihood.
- The fish waste provides 10 essential nutrients needed for plant growth out of the 13 nutrients.
- The fish waste decomposes to ammonia which is oxidized by nitrifying bacteria to give Nitrites which is further oxidized by nitrogen fixing bacteria to give Nitrates which can be absorbed by plants.

#### METHODOLOGY

- Aquaponics is of sustainable food system in one process, the that fish leaves in the make the latter grow. effluents refer to the

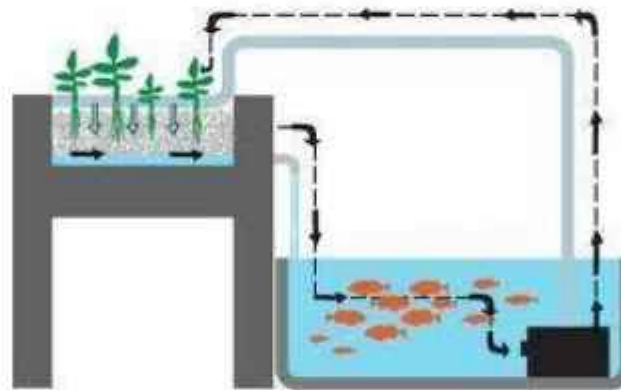

FIGURE 2: A traditional aquaponic system

### 3. COMPONENTS USED

TABLE 1: Components required and their specifications.

| Sl. No | Components Required |               |
|--------|---------------------|---------------|
|        | Component           | Specification |
|        |                     |               |



|    |                         |  |
|----|-------------------------|--|
| 1  | Aquarium                | 15-20 gallons                          |
| 2  | Grow bed                | 10 gallons capacity                    |
| 3  | Motor                   | Boyo 2500(any locally available motor) |
| 4  | PVC Tube                | 0.5 inches, 3 inches                   |
| 5  | Pipes                   | 0.5 inches(length as per requirement)  |
| 6  | Air pump, sponge filter | For 55l capacity                       |
| 7  | Arduino Microprocessor  | 8bit AVR microcontroller               |
| 8  | Temperature Sensor      |  |
| 9  | Humidity Sensor         |  |
| 10 | OxygenPercentage sensor |  |
| 11 | AuxiliaryBattery        | 12 V                                   |
| 12 | LCD display             |  |
| 13 | Solar Panel             | 36 cells                               |
| 14 | Timer relay             |  |

**The species of plants and fishes used into the system are:**

Aloe vera(Aloe vera),Cluster Beans(Cyamopsis tetragonoloba),Chilly(Capsicum frutescens),Ginger(Zingiber officinale), Onion(Allium cepa) in an area of 0.27meter square. Fish used: Tilapia(Oreochromis niloticus) Neem oil and tobacco mixed with water are the organic pesticides used in the system. The above mentioned system is the basic model of an aquaponics system which requires frequent pumping of water. This system is most suitable for common household where there is a person to supervise all day. The system can be further modified with a help of Arduino microcontroller board for switching ON and OFF the motor using time delay mode. This system can also be made more self-sustaining using solar power to harness the power required. Arduino is suggested for this purpose of automation because it provides a userfriendly interface and program can be learnt by any lay man. Moreover,solar power panels can be easily fixed by the farmers above the system as required

**4. CONCLUSION**

Small scale aquaponic system is certainly the best solution for growing organic vegetables at homes in crowded cities as the space and water requirement for this system is less. It is an eco-friendly technology which can be improvised and made energy efficient at an individual's convenience and pattern of usage.

**REFERENCES**

- [1] Sylvia Bernstein, "Aquaponic Gardening a Step by Step Guide to Raising Vegetables and Fish Together," New society publishers.
- [2] Michael Sogaard Jorgensen, "Green Technology Foresight about Environmentally Friendly Products and Materials," A report submitted by Danish ministry of environment, report no. 34, 2006.
- [3] John Pade, "10 thoughts on system design," Aquaponics journal, Issue #46, 3<sup>rd</sup> quarter, 2007.

- [4] A.J. Both "Ten Years of Aquaponics Research," The State University of New Jersey.
- [5] Elisha R. Goodman "Aquaponics Community and Economic Development," Master in city planning at Massachusetts Institute of Technology, 2011.
- [6] Groov Elisa "Communal Aquaponic and Climatic Challenges," Master in Green Engineering at Callifonian Institute of Technology, 2011.
- [7] Nick Savidov, "Evaluation and development of product market capabilities in Alberta," Ids initiative fund final report, August 17, 2004.

## POWER ASSISTED POULTRY GARBAGE CHIPPING MACHINE

Amith Kumar M<sup>1</sup>, Jagadeesh Prasad S K<sup>1</sup>, Shashikiran A<sup>1</sup>, Nagabhushana M<sup>2</sup>

<sup>1</sup> Students, <sup>2</sup> Associate Professor  
Department of Mechanical Engineering  
K.S. Institute of Technology Bangalore -560109

### ABSTRACT

*This project is to design, implement of Poultry raking machine. The rapidly growing population has created some doubts in the said hypothesis. In fact, crop production alone may not solve the food problem of the country. The chief ingredients of balanced diet also comprise proteins, fats, minerals and vitamins, which are essential for growth. The supply of these items can easily be increased through increased production of livestock products. The present study has been undertaken to examine various aspects related to the growth and development of poultry production in the country.*

**Keywords:** Powered assisted poultry garbage, waste management, Variable Frequency Drive, Induction Motor

### 1. INTRODUCTION

Raking is necessary to keep poultry in good health. Due to scarcity of labour and efforts require for conditioning the litter, farmer faced problem for doing raking manually in poultry farm. We started thinking to mechanize it by developing a machine. We were able to develop the product called poultry raking machine.

It is being used for turning/disturbing the layers from bottom to top of poultry wastes accumulated in the farm. This exposes ammonia and nitrogen to atmosphere which is present in the animal wastes. Proper raking reduces the mortality rate of chicks and enhances the proper growth of chick by minimizing the disease spread.

### 2. MATERIALS

The components used in the poultry machine were as follows.

#### 2.1 Induction Motor



FIGURE 1: Induction Motor

An induction motor or asynchronous motor is an AC electric motor in which the electric current in the rotor needed to produce torque is obtained by electromagnetic induction from the magnetic field of the stator winding. An induction motor can therefore be made without electrical connections to the rotor. An induction motor's rotor can be either wound type or squirrel-cage type.

Three-phase squirrel-cage induction motors are widely used as industrial drives because they are self-starting, reliable and economical. Single-phase induction motors are used extensively for smaller loads, such as household appliances like fans. Although traditionally used in fixed-speed service, variable-speed service, VFDs offer especially important energy savings opportunities for existing and prospective induction motors in variable-torque centrifugal fan, pump and compressor load applications. Squirrel-cage induction motors are very widely used in both fixed-speed and variable-frequency drive applications.

### 2.3 Variable Frequency Drive



FIGURE 2: VFD Drive

A variable-frequency drive (VFD; also termed adjustable-frequency drive, "variable-voltage/variable-frequency (VVVF) drive" is a type of adjustable-speed drive used in electro-mechanical drive systems to control AC motor speed and torque by varying motor input frequency and voltage.

VFDs are used in applications ranging from small appliances to large compressors. About 25% of the world's electrical energy is consumed by electric motors in industrial applications, which can be more efficient when using VFDs in centrifugal load service; however, VFDs' global market penetration for all applications is relatively small.

### 2.3 V-BELTS

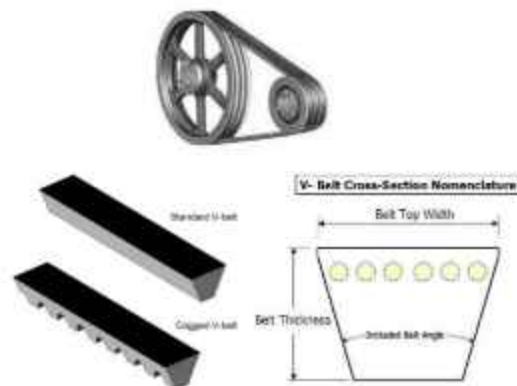

FIGURE 3: V Belt

V-belt (also called vee belt sheaves) are devices which transmit power between axles by the use of a v-belt, a mechanical linkage with a trapezoidal cross-section. Together these devices offer a high speed power transmission solution that is resistant to slipping and misalignment. V-belt pulleys are solely used for transmitting power between

two parallel axels. The most notable difference between a v-belt pulley and other types of pulleys (round belt, flat, etc.) would be the geometry of the groove or grooves located around the circumference of the pulley; these grooves guide and gain traction on a v-belt. The accompanying video offers a comprehensive overview of some v-belt basics, as well as their advantages and variations.

## 2.4 PULLEY



FIGURE 4:Pulley

A pulley is a wheel on an axle or shaft that is designed to support movement and change of direction of a taut cable or belt, or transfer of power between the shaft and cable or belt. In the case of a pulley supported by a frame or shell that does not transfer power to a shaft, but is used to guide the cable or exert a force, the supporting shell is called a block, and the pulley may be called a sheave. A pulley may have a groove or grooves between flanges around its circumference to locate the cable or belt. The drive element of a pulley system can be a rope, cable, belt, or chain.

## 2.5 SPEED CONTROLLER SWITCH



FIGURE 5: Speed Controller Switch

An electronic speed control follows a speed reference signal (derived from a throttle lever, joystick, or other manual input) and varies the switching rate of a network of field effect transistors (FETs) .[1] By adjusting the duty cycle or switching frequency of the transistors, the speed of the motor is changed. The rapid switching of the current flowing through the motor is what causes the motor itself to emit its characteristic high-pitched whine, especially noticeable at lower speeds. Different types of speed controls are required for brushed DC motors and brushless DC motors. A brushed motor can have its speed controlled by varying the voltage on its armature. (Industrially, motors with electromagnet field windings instead of permanent magnets can also have their speed controlled by adjusting the strength of the motor field current.) A brushless motor requires a different operating principle. The speed of the motor is varied by adjusting the timing of pulses of current delivered to the several windings of the motor.

## 2.6 Toggle Switch



FIGURE 6: Toggle Switch

A toggle switch is a graphical control element that allows the user to make a choice between two mutually exclusive states (such as on/off). Originally toggle switches were used primarily in touchscreen-based user interfaces, but they have later become commonplace in desktop and web applications. Toggle switches have a similar function as checkboxes, but unlike checkboxes, interacting with a toggle switch usually has an immediate effect on the application or system.

A toggle switch is a type of electrical switch that is actuated by moving a lever back and forth to open or close an electrical circuit. There are two basic types: maintained contact and momentary toggle switches. A maintained switch changes its position when actuated and will remain in that position until actuated again, such as an ON/OFF function. A momentary toggle switch is actuated only when someone is operating the switch. We design and manufacture a wide range of toggle switches with several mounting options. Our broad portfolio includes toggle switches with different actuator styles and amperage ranging from 3 to 20 amps, as well as different load-carrying capabilities and locking combinations. Further, we offer switches with and without guards to prevent accidental switching as well as individual switches and complete switch assemblies with additional sealed housings.

## 2.7 IDLER PULLEY



FIGURE 7: Idler Pulley

In a belt drive system, idlers are often used to alter the path of the belt, where a direct path would be impractical. Idler pulleys are also often used to press against the back of a pulley in order to increase the wrap angle (and thus contact area) of a belt against the working pulleys, increasing the force transfer capacity. Belt drive systems commonly incorporate one movable pulley which is spring- or gravity-loaded to act as a belt tensioner, to accommodate stretching of the belt due to temperature or wear. An idler wheel is usually used for this purpose, in order to avoid having to move the power transfer shafts.

## 2.8 Dead Shaft Idler Rolls



FIGURE 8: Dead Shaft Idler Pulley

With a Dead shaft idler, bearings are installed in each end of the roller body and the shaft passes through the body of the roll. The shaft is mounted to the framework of a machine and the roll body rotates around the fixed shaft. The shaft does not rotate so it is called a dead shaft.

## 2.9 Chassis:



FIGURE 9. Chassis

A chassis is the load-bearing framework of an artificial object, which structurally supports the object in its construction and function. An example of a chassis is a vehicle frame, the underpart of a motor vehicle, on which the body is mounted; if the running gear such as wheels and transmission, and sometimes even the driver's seat, are included, then the assembly is described as a rolling chassis.

## 2.10 COVER:



FIGURE 10. Cover

A cover is often a structural system that supports other components of a physical construction. The cover is design to cover the internal parts of machine. It is fabricated using sheet metal to cover internal parts from dust can also provide protection for some internal part.

### 2.11 Chipping Blades:

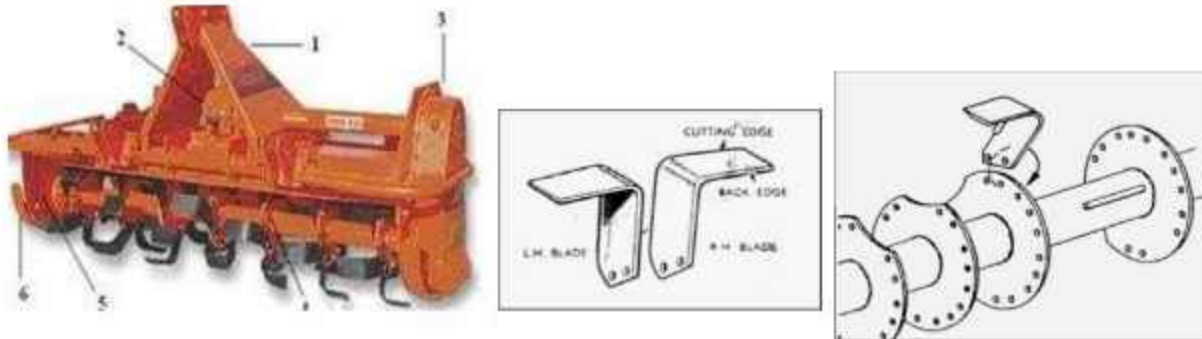

FIGURE 11. Chipping Blades

The rotavator is a tillage tool primarily comprising of L-shape blades mounted on flanges that are fixed to a shaft and it is driven by the tractor power-take-off (PTO) shaft. In comparison to passive tools, the rotavator has a superior soil mixing and pulverization capability. During rotavator tillage operations various factors affect its energy requirements. These factors can include soil conditions, operational conditions and rotavator configuration.

### 2.12 Roller Coaster Wheels:



FIGURE 12. Roller Coaster Wheel

Today's modern roller coasters, both wooden and steel, have the same basic design of wheel assembly. Each wheel assembly has three wheels: under friction, or up-stop, wheels; tractor, or running, wheels; and side friction wheels. All of these help the train move safely and smoothly. All modern roller coasters have up-stop wheels that hug the bottom of the rail. As their name implies, they prevent the train from coming up off the track. Side friction wheels hug the sides of the rail, either the outside or inside, depending on the track manufacturer. These wheels help the train stay in the center of the two rails to keep the train from derailing. The last wheel set are called tractor wheels, or running wheels. Tractor wheels have a simple but important purpose. These wheels bear the weight of the train on the track, keeping the train running on the track. Tractor wheels may lift off the track in when the vertical g-force is zero or negative, but the up-stop wheels keep the train from coming completely off the rails.



### 3. FABRICATION PROCESS

Operation involved in manufacturing poultry garbage chipping machine:

- Marking
- Metal cutting
- Drilling
- Turning
- Welding
- Grinding
- Buffing
- Painting

### 4. CONCLUSIONS

A machine was built and tested. The machine is capable of cleaning a poultry shed area of 5000 sqft per hour. Certain problems (higher stress generation) were observed in the process in the blade. This was sorted out by increasing the thickness of the plate( present thickness of blade is 4mm)

- Initially EN8 was used for blade material and later material was changed to EN24 Steel due to its high strength which gives longer life compared to EN8.
  - The load condition is applied for existing and modified design blades.
  - EN24 material is producing lesser stress compared to EN8.
- Also EN24 can give better wear resistance compared to EN8 which is a key parameter for longer life of the blade.

### ACKNOWLEDGMENTS

We would like to express our gratitude to our project guide **Mr. Nagabhushana M, Associate professor** and also express our gratitude to **Dr. Nirmala L, Student Project Coordinator**, for having given this opportunity and support to carry out our project work.

### REFERENCES

- [1] Godwin R.J, O "Dogherty" M.J (2006) "Integrated soil tillage force prediction models" Vol. 44, pp. 3-14.
- [2] Gopal U. Shinde and Shyam R. Kajale (2012) Design optimization in rotary tillage tool system components by CAEA Vol. 3, No. 3, pp. 279-282.
- [3] Khalid Usman, Ejaz Ahmad Khan, Niamatullah Khan (2013) Effect of Tillage and Nitrogen on Wheat Production, Economics, and Soil Fertility in Rice-Wheat Cropping System Vol. 4, pp. 17-25.
- [4] Mahesh M. Sonekar 1, Dr. Santosh B. Jaju (2011) Fracture analysis of exhaust Manifold stud of Mahindra Tractor through finite Element method (FEM) – a past Review Vol. 3, pp. 131-135.
- [5] Rahul Davis (2012) Optimization of surface roughness in wet turning operation of EN24 steel Vol. 2, Issue 3, pp. 28-35.
- [6] Rahul Davis, Jitendra Singh Madhukar (2012) A parametric analysis and optimization of tool life in dry turning of en24 steel using taguchi method Vol. 3, Issue 1, pp. 9-15.
- [7] Subrata Kr. Mandal and Basudeb Bhattacharyya (2013) Design & Development of rotavator blade: Interrogation of CAD method" Vol. 1, No. 10, pp. 439-447.
- [8] Venkatasiva S.B, Srinivasarao G, Mahesh kumar M(2012) Study of phase transformations in EN8 steel material using acoustic emission technique Vol. 1, pp. 541-550.
- [9] Zarroug.N.M, Padmanabhan.R, MacDonald.B.J, Young.P, Hashmi.M.S.J (2003) Mild steel (EN8) rod tests under combined tension-torsion loading Vol. 143.

## DESIGN AND FABRICATION OF A SEMI-AUTOMATIC PNEUMATIC INJECTION MOLDING MACHINE

Yateesh H Jamadade<sup>1</sup>, A.K. Aditya<sup>1</sup>, Nihal M Poojary<sup>1</sup>, Akhil Purohith<sup>1</sup>, Parashuram A.K<sup>2</sup>

<sup>1</sup> Students, <sup>2</sup> Associate Professor  
Department of Mechanical Engineering  
K.S. Institute of Technology Bangalore -560109.

### ABSTRACT

*In this study, a concept of low cost injection molding system is presented. A prototype of a vertical injection molding machine has been designed and built based on the basic principles of injection molding. The developed system consists of plunger, melting chamber and custom-made mold. The plunger is used to deliver plastic melt from the melting chamber into the specific shape of the mold cavity. The performance of the custom-made machine is tested by successfully fabricated tensile specimen, Izod specimen, microchannels and gear shapes. The machine is capable of producing plastic parts of various shapes and sizes.*

**Keywords:** Injection Moulding, Pneumatic.

### 1. INTRODUCTION

Injection Moulding is a manufacturing process for producing parts from both thermoplastic and thermosetting plastic materials. Material is fed into a heated barrel, mixed, and forced into a mold cavity where it cools and hardens to the configuration of the mold cavity. The plastic injection moulding industry has evolved over the years from producing combs and buttons to producing a vast array of products for many industries including automotive, medical, aerospace and consumer products. The Machine parts analysis using feature based methodology. This approach allows robust design of part components. This is also useful for parting plane and product layout.

### 2. MACHINE COMPONENTS

The pneumatic Moulding Machine Consist of various components. The Machine is mainly divided into two units –Injection unit & Clamping Unit. Injection Unit having components are Cylinder, Barrel, Screw, Backflow Prevention Valve, Nozzle & Heater. Clamping unit consist of Clamp, Exhaust Valve & Die Assembly parts.

**Injection Cylinder:** There are many types of injection cylinders that supply necessary power to inject resins according to the characteristics of resins and product types at appropriate speed and pressure. This model employs the double cylinder type. Injection cylinder is composed of cylinder body, piston, and piston load. [5] Design of Cylinder consist of – (a) Cylinder Thrust (b) Air Consumption (c) Mounting

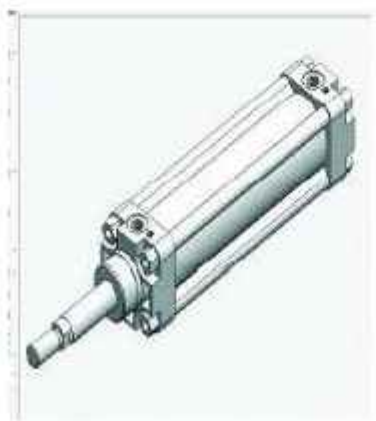

**Barrel:** Nitride Steel barrel are used for Lupilon /Novarex plastic resins is good. The Barrel consists of cooling water channel, heater bands, Thermocouple whose function is to note the temperature in various section of barrel. The time it takes for the plastic material from entering the barrel to the nozzle is called the residence time [6]

**Nozzle:** Nozzle is located at the end of barrel which provides melt can leave barrel and enter into the mould. melt can be heated here by friction and conduction from a heater band before entering the relatively cold channels in the mould. Contact with the mould causes heat transfer from the nozzle and in cases where it is excessive it is advisable to withdraw the nozzle from the mould during the screw-back part in the moulding cycle. Otherwise the plastic may freeze-off in the nozzle [6].

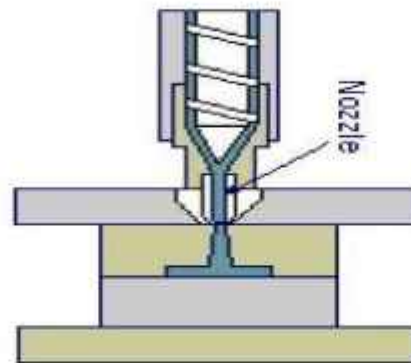

**Clamp Mechanism:**Clamping is used to keep the mould tightly closed under sufficient pressure to let the molten plastic fill in the cavity without leaking during the injection process.

**Heater:** The Plastic resins are moulded at high temperature. the heater with heat capacity can be heated to about 150-350°C is used, and a band heater is usually used.

**Collar/Hopper:** Collar is the channel along with the molten plastic first enters the mould through the cylinder pipes. It delivers the melt from the nozzle to the runner system.



**Direction Control Valve( 5/2 DCV):** DCV are one of the most fundamental parts of hydraulic and pneumatic systems. DCVs allow fluid flow (hydraulic oil, water or air) into different paths from one or more sources. DCVs will usually consist of a spool inside a cylinder which is mechanically or electrically actuated. The position of the spool restricts or permits flow, thus it controls the fluid flow.

**Base:** It's the base of the machine which provides stability to the whole machine structure. Its helps in anchoring the machine , it also houses the clamping mechanism.**RL Unit:** Filter, regulator, and lubricator (FRL) compressed air systems are used to deliver clean air, at a fixed pressure, and lubricated (if needed) to ensure proper pneumatic component operation and increase their operation lifetime

**PNEUMATIC SWITCH:** The pneumatic switch actually starts the manufacturing process by sending the start signal to the control unit.

**DIE:** A die is usually made in two halves and when closed it forms a cavity similar to casting desired. One half of the die remains stationary is known as "cover die" and the other movable half is called "ejector die".

### 3. ASSEMBLING OF MACHINE

Machine cannot create energy by itself. Therefore machine requires prime mover. In most of machines prime mover is an electric motor 3 phase induction motor in case of injection moulding machine. In this machine electrical energy is converted into mechanical energy by using pneumatic compressed system. For the Pneumatic compression injection Cylinder is used. FRL unit is used for filtration, regulation and lubrication of the compressed air. Temperature sensors is used for controlling the temperature of dies, asbestos, and glass wool for

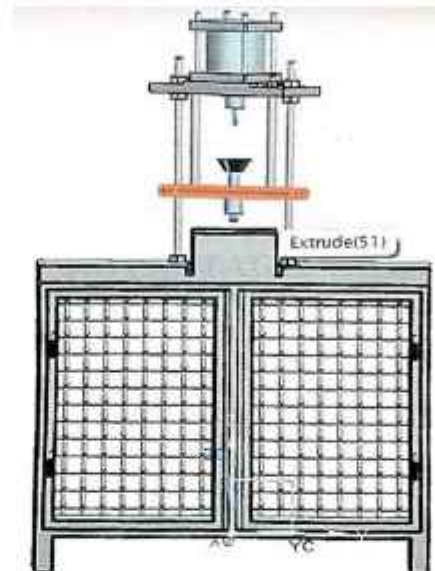

the insulation between piston rod and dies, a frame is used for the equal distribution of load on the material to be produced by using this machine. Molding compound is placed in an open and heated mold cavity. The mold is closed and the pressure is applied to force the material to fill up the entire mold cavity. The heat and pressure is maintained until the plastic material is cured. Once the material is cured it is removed from the mold for finishing.

### 4. CONCLUSION

Designing of machine components are considered as a very important task now a days The machine is designed and developed at comparable low cost and pneumatic systems are easy to maintain as the working fluid is air , the environment around the machine is contamination free compared to hydraulic version of the machine .

### REFERENCES

- [1]Pravin popatrao Shinde, S S Patil, Swapnil S Kulkarni "Design & Development of Plastic Injection mould for auto components" in International Journal of Advanced Engineering Research and Studies, Vol. 4 Issue 1 Oct-Dec. 2014, Pages 27-30.
- [2]L.M. Galantucci, R Spina, " Evaluation of filling conditions of injection moulding by integrating numerical simulation and experimental tests" in ELSEVIER-Journal of Material processing & Technology, 141(2003) Pages 266-275.
- [3]Sharifah Imihezri Syed Shahrudin, Mohd. Sapuan Salit,Edi Syams Zainudin, "A review of the effect of Moulding parameters on the Performance of polymeric composite injection Moulding" Turkish J Engg. Env. Sci., 30, 2006, Pages 23-34.
- [4]Eranna H, "Development of Pneumatically operated compression Moulding Machine" in International Journal of Engineering Research, Vol.2 Issue 4 oct. 2014, Pages 62-67.
- [5]Poonam G Shukla, Gaurav p Shukla, "Design & Fabrication of Pneumatically operated injection Moulding Machine, in International Journal of Engineering & innovative Technology (IJEIT), Vol. 2, Issue 7, January 2013, Pages 98-101.

[6] Crawford, R., 1998. Plastic Engineering, 3rd ed. Oxford: Butterworth – Heine-mann.

## EXPERIMENTAL & NUMERICAL INVESTIGATION ON VIBRO-ACOUSTIC BEHAVIOUR OF THIN CYLINDRICAL SHELLS

<sup>1</sup>Rakshith A, <sup>1</sup>Sanjay Rao G, <sup>1</sup>Srinivas R, <sup>1</sup>D Manish, <sup>2</sup>Mr. Anil Kumar A

<sup>1</sup>Students, <sup>2</sup>Assistant Professor  
Department of Mechanical Engineering  
K.S.Institute of Technology, Bengaluru, Karnataka, India

### ABSTRACT

*Vibrations are the engineering complexity that we are facing in our daily life, which is undesirable based on their occurrence and the circumstance. Vibrations will have adverse effects on durability, life and loss of characteristics among other effects on the machine part/component. This must be avoided or controlled because, if the vibrations exceed a certain point, the component will fail due to the phenomenon of resonance. This paper deals with vibrations and acoustics behaviour of thin cylindrical shells of very large radius of curvature, which finds its applications in the field of automobiles, aerospace and etc. In this work an investigation on natural frequency of thin cylindrical shell structures were carried out experimentally for CRC steel with and without internal voids. The shell element of different radii of curvature (1000mm, 1500mm, 2000mm) were fabricated and tested under different boundary conditions. The modal frequencies and modal spectrums of the thin cylindrical shells are investigated by experimental methods.*

**Keywords:** Natural frequency, Internal voids, Shells, Radius of Curvature, Boundary Condition, Modal Frequencies.

### 1. INTRODUCTION

A shell is a type of structural element which is characterized by its geometry, the term shell is applied to bodies bounded by two curved surfaces, where distance between the surfaces is small in comparison with other body dimensions. ( Depending on curvature of surface, shells are divided into cylindrical, conical, spherical, ellipsoidal shells. There are different classes of shells, thick shells and thin shells. A shell is called thin if maximum value of  $h/R$  ( $h$ -thickness and  $R$ -Radius of curvature of middle surface) is  $\max(h/R) \leq 0.05$ . If shells for which this condition is violated are referred to as thick shells. For a large number of practical application thickness of shell lies in the range  $0.001 \leq h/R \leq 0.05$  i.e., in the range of thin shells[1]. Thin walled, cylindrical structures are found extensively in both engineering components and in nature.

Any motion that repeats itself after certain interval of time is called vibrations. Vibrations occurs when system is displayed from the position of equilibrium. All bodies having masses and elasticity are capable of vibrating. When the frequency of the external excitation equals to the natural frequency of the system, the system response to it with increased amplitude. This condition is called resonance and frequency is called resonant frequency. Vibrations is harmful in mechanical system because of noise, high amplitude of vibration at resonant condition and damage to the machine component. So, in vibration engineering the goal is to remove bad vibration or reducing the amplitude of vibration. A commonly practiced method for reducing unwanted vibration and radiated noise from a structure is the implementation of passive constrained layer damping treatment due to its effectiveness and cost efficiency. Information regarding the effects of such damping treatments is still sparse and the techniques for application are still empirical, though some works have investigated mathematically derived optimization techniques for patch placement on plate [2]

This paper focuses on the vibration and damping analysis of three-layered sandwich cylindrical shells with stiff steel face layers and a viscoelastic core. Then, impact hammer method was used to study the natural frequencies of the cylindrical shell structures of radius of curvature 1000mm, 1500mm & 2000mm, subjected to Free-Free (FF), Cantilever condition(FFFC), Two sides fixed (FCFC) & all sides fixed (CCCC) boundary conditions. Also the acoustic behaviour was recorded by using the near field approach.[3]

### 2. MATERIALS AND METHODS

As steel is the commonly used material in automobiles & aerospace structure, the present paper focuses on the Vibro-acoustic behaviour of steel panels. Cold rolled steel sheets offer variety of outstanding properties including

easy formability and a smooth clean surface and has minimal deviation in mechanical properties. These are best suited for automobile electrical appliances due to high strength and improved formability. Due to the good properties and formability of CRC sheets, this material was apt for our requirements. The long CRC sheets were cut to the required dimensions with the help of hydraulic cutting machine, the CRC sheets were rolled with the help of rolling machines. And also, to mount the sides of the shell structure on the fixture for testing, the sides of the specimen were flattened with the help of bending machine.



FIGURE1: Cutting & rolling of CRC Steel sheets

For dampening the vibration effect of the shell structures, a perforated sheet made up of the same material was sandwiched between a pair of rolled CRC sheets. In order to sandwich the layers, the material was cleaned with the help of emery paper and thinner to remove the dirt and grease. Then the sheets were glued with the help of Bond Tite–Ametalmetal glue manufactured by Astral Adhesives and the fabricated shell structures are as shown in Fig2. Dimensions of the shell structures are as shown in Table1.

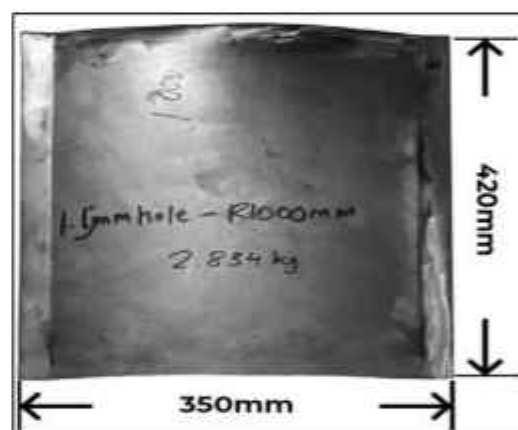
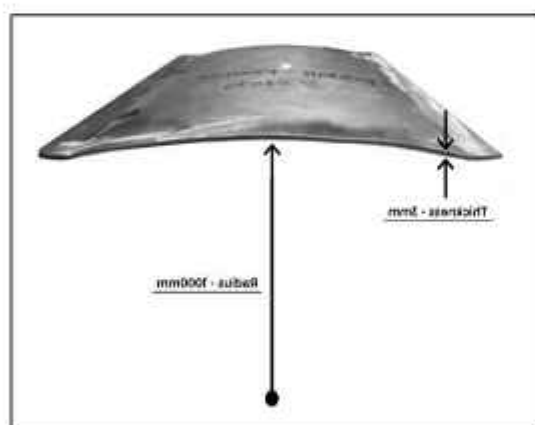

FIGURE2: Fabricated shell structures.

TABLE 1: Dimensions of the Shell Structure.

| SL.No | Thickness (h) | Radius of Curvature (R) | (h/R) ratio |
|-------|---------------|-------------------------|-------------|
| 1     | 3mm           | 1000mm                  | 0.003       |
| 2     | 3mm           | 1500mm                  | 0.002       |
| 3     | 33mm          | 2000mm                  | 0.0015      |

### 3. EXPERIMENTATION

The natural frequencies of the cylindrical shell was found using the impact hammer method. In this method the specimen was rigidly clamped to the fixture and an accelerometer was fixed to the specimen to capture the vibrations from the specimen, when it is excited by the hammer. The mechanical signals generated because of the impact force from the hammer was captured and transmitted to the FFT analyser, where the mechanical signals are converted to electrical signals. Finally the results were fed in to the computer and analysed by using Simens Multi-channel Data Acquisition System LMS test labs software as sown in fig3.

FIGURE 3: Experimental setup of Impact hammer method



### 4. RESULTS

The impact hammer method was used to find natural frequencies of the cylindrical shell structures of 1000mm, 1500mm & 2000mm radius of curvature & with no voids, 1mm internal voids and 1.5mm internal voids, subjected to the FF, CCCF, CFCF, CCCC boundary conditions. The variation of natural frequencies with boundary conditions and radius of curvature is as shown in Table2-Table4. From the tables it is clearly seen that shells under all sides fixed ( CCCC) boundary conditions exhibits higher natural frequencies, because as the shells are fixed on all the sides increases stiffness, which intern increases natural frequency. And also shells with 1.5mm voids and 2000mm radius of curvature exhibits better vibration charecteristics.

TABLE 2: Natural frequencies of Cylindrical shell with no voids subjected to FF, CCCF, CFCF, CCCC boundary conditions

#### Comparison with respect to Radius of Curvature (No Internal Void)

| Condition \ Radius | Free Free | Cantilever | Two Sides Fixed | All Side Fixed |
|--------------------|-----------|------------|-----------------|----------------|
| R1000              | 127       | 26         | 207             | 250            |
|                    | 460       | 151        | 465             | 518            |
|                    | 698       | 711        | 752             | 814            |
| R1500              | 196       | 150        | 214             | 254            |
|                    | 702       | 711        | 611             | 381            |
|                    | 896       | -          | 786             | 684            |
| R2000              | 127       | 140        | 424             | 243            |
|                    | 367       | 365        | 668             | 429            |
|                    | 829       | 6922       | 826             | 634            |



**TABLE 3:** Natural frequencies of Cylindrical shell with 1mm voids subjected to FF, CCCF, CFCF, CCCC boundary conditions

| Condition \ Radius | Free Free | Cantilever | Two Sides Fixed | All Side Fixed |
|--------------------|-----------|------------|-----------------|----------------|
| R1000              | 151       | 16         | 348             | 374            |
|                    | 288       | 189        | 389             | 414            |
|                    | -         | -          | -               | 704            |
| R1500              | 16        | 14         | 316             | 358            |
|                    | 295       | 197        | 527             | 697            |
|                    | 570       | -          | 732             | 733            |
| R2000              | 161       | 19         | 251             | 344            |
|                    | 505       | 68         | 497             | 362            |
|                    | -         | 189        | 885             | 491            |

**TABLE 4:** Natural frequencies of Cylindrical shell with 1.5mm voids subjected to FF, CCCF, CFCF, CCCC boundary conditions

| Condition \ Radius | Free Free | Cantilever | Two Sides Fixed | All Side Fixed |
|--------------------|-----------|------------|-----------------|----------------|
| R1000              | 165       | 21         | 388             | 428            |
|                    | 277       | 199        | 578             | 447            |
|                    | 610       | -          | 734             | 755            |
| R1500              | 108       | 17         | 276             | 338            |
|                    | 133       | 168        | 543             | 366            |
|                    | 463       | -          | 905             | 627            |
| R2000              | 140       | 17         | 260             | 411            |
|                    | 306       | 172        | 650             | 436            |
|                    | -         | 209        | -               | 720            |

As the vibrations induces noise also the noise emitted from the cylindrical shell structure was found out and the variation of noise emitted from the shell structures in as shown in Table5- Table7. From the tables it is clearly seen that shells with 1mm and 1.5mm holes exhibits better acoustic properties.

**TABLE 5:** Noise radiated from a cylindrical shell of 1000mm radius of curvature with no voids, 1mm voids and 1.5mm voids.

| Condition \ Voids | Free-Free | Cantilever | Two Sides Fixed | All Side Fixed |
|-------------------|-----------|------------|-----------------|----------------|
| No voids          | 59.8      | 57.3       | 50.5            | 50.9           |
| 1mm voids         | 52.5      | 52.6       | 51.9            | 55.1           |
| 1.5mm voids       | 50.9      | 51.3       | 47.3            | 33.6           |

**TABLE 6:** Noise radiated from a cylindrical shell of 1500mm radius of curvature with no voids, 1mm voids and 1.5mm voids.

| Condition \ Voids | Free-Free | Cantilever | Two Sides Fixed | All Side Fixed |
|-------------------|-----------|------------|-----------------|----------------|
| No voids          | 42.3      | 43.4       | 49.9            | 48.3           |
| 1mm voids         | 51.7      | 52.1       | 43              | 44             |
| 1.5mm voids       | 51.8      | 51.2       | 49.1            | 50.6           |

**TABLE 7:** Noise radiated from a cylindrical shell of 2000mm radius of curvature with no voids, 1mm voids and 1.5mm voids.

| Condition \ Voids | Free-Free | Cantilever | Two Sides Fixed | All Side Fixed |
|-------------------|-----------|------------|-----------------|----------------|
| No voids          | 57.3      | 51.6       | 53.6            | 52.5           |
| 1mm voids         | 50        | 49.7       | 51.6            | 50.4           |
| 1.5mm voids       | 53.2      | 42.3       | 47.6            | 52.3           |

## 5. CONCLUSIONS

From the present study the following conclusions can be drawn

- Thin cylindrical shells of CRC Steel Sheet of different radii of curvature (1000mm, 1500 mm, 2000 mm) with and without internal voids (1mm, 1.5mm) were fabricated.
- Dynamic analysis of these cylindrical shell structures was carried out for four different boundary conditions i.e., all sides fixed Boundary condition, two sides fixed, free boundary condition, Cantilever Condition, Free Free/Hanging Condition using Impact Hammer method.
- As the stiffness increases in all sides fixed boundary condition when compared to other boundary conditions, shell structure with All sides fixed boundary condition exhibited higher frequency than that of other boundary conditions.
- From experimentation it is found that the cylindrical shell structure with 1mm & 1.5mm Internal Voids exhibited higher natural frequency than cylindrical shell structure without any Internal Voids due to damping effect.
- We can conclude that the natural frequency increases with an increase in radius of curvature of the shell structure, as the radius increases the stiffness of the shell structure decreases and behaves like a plate.

## REFERENCES

- [1] Mayur Vekariya, Ashish H. Makwana, Head & Assistant Professor, Civil Engineering department, Pacific School of Engineering, V: Sanki, Ta. Palsana, Surat-394305, Gujarat, India Planning Engineer, Tata Projects Ltd., Ahmedabad-380051, Gujarat, India.
- [2] Matthew A. Dawson, Lorna J. Gibson b a Department of Mechanical Engineering, Massachusetts Institute of Technology, Cambridge, MA 02139, United States.
- [3] Erdem Yuksel, Gulsen Kamci and Ipek BasdoganKoc University, Mechanical EngineeringDepartment, Sariyer, Istanbul, 34450, Turkey.
- [4] Xianzhong Wang, Di Chen, Yeping Xiang, Weiguo Wau 2211-3797/ © 2019 The Authors. Published by Elsevier B.V. This is an open access article under the CC BY-NC-ND license.
- [5] C.A. Dimopoulos n, C.J. Gantes Metal Structures Laboratory, School of Civil Engineering, National Technical University of Athens, Greece.
- [6] Materials Science, Vol. 55, No. 4, January, 2020 (Ukrainian Original Vol. 55, No. 4, July–August, 2019) DOI 10.1007/s11003-020-00331-2.
- [7] Journal of Mathematical Sciences, volume.2 ,1072-3374/11/1742–0254, A.Ya. Grigorenko, S.V. Puzyrev, A.P. Prigoda and V.V. Khorishko.

## EFFECT OF COMBINATION OF ETHANOL INJECTION AND AFTER TREATMENT DEVICES ON DIESEL ENGINE EMISSION- A REVIEW

<sup>1</sup> Nithin kumar , <sup>2</sup> Pavan kumar , <sup>3</sup> Santhosh K, <sup>4</sup> Sohith S, <sup>5</sup> Nagaprasad K S

<sup>1 2 3 4</sup> UG-students, <sup>5</sup> Associate Professor  
Department of Mechanical Engineering  
K.S. Institute of Technology Bangalore -560109

### ABSTRACT

*Internal combustion engine is established as the main power source for automobile vehicles. At present emission norms becomes strict for any I.C. Engine. The main pollutant is CO, HC, NOx, PM, soot, etc. The aim of this work is to inject Ethanol to reduce the emission norms like CO, HC, NOx, PM, soot and by using after treatment devices.*

*Experiments were conducted on a four stroke water cooled single cylinder, compression ignition engine. All tests were conducted at different loads: At 0kg, 3kg, 6kg, 9kg, 12.5kg load. The engine speed is maintained constant at 1500 rpm. Diesel engine was running at 1500 rpm, rated power 3.5 KW, Compression ratio 18:1.*

Keywords: Diesel Engine ,Diesel Particulate Filter(DPF),Catalytic Converter(CC),Engine Emissions

### 1. INTRODUCTION

Diesel engine is an interior burning engine where in start of the fuel is brought about by the raised temperature of the air in the chamber because of the mechanical pressure. Diesel engines works by packing just the air. This builds the air temperature inside the chamber to such a serious level that atomized diesel fuel infused into the burning chamber lights suddenly. In any case, the issue with diesel engine is its higher pace of contamination discharges. Among the fundamental contaminations Nitrogen Oxides (NOx), Carbon Monoxide (CO), Hydrocarbons (HC), Particulate Matter (PM), Carbon Dioxide (CO<sub>2</sub>), Sulphur Dioxide (SO<sub>2</sub>), aldehydes most unsafe poisons of diesel engine are NOx and PM. To adapt to the exacting discharge standard, green engine which diminishes exhaust emanation ought to be created. Execution of after-treatment frameworks like Diesel particulate channel (DPF), incite critical increase in outflows decrease were attempted. Diesel particulate channels (DPF) is the gadgets that truly catch diesel particulate matter in the Fumes line to forestall the Delivery to the Climate.

### 2. DIESEL ENGINE

A 4-stroke engine is a very common variation of an internal combustion engine. Most modern internal combustion-powered vehicles are 4-strokes, powered by either gasoline or diesel fuel. During engine operation, pistons go through 4 events to achieve each power cycle. The definition of an event is an up or down piston motion. Upon completion of the 4 events, the cycle is complete and ready to begin again. 4-stroke engines deliver a good balance of power, reliability and efficiency. When it comes to emissions, 4-strokes separate each event mechanically, which reduces unburned fuel emissions. It also separates oil from fuel, which significantly reduces carbon monoxide emissions. This combination of desirable traits has earned the 4-stroke the top spot in passenger vehicles today.



FIGURE 1. Diesel Engine

### 3. DIESEL PARTICULATE FILTER

The particulate filter consists of a porous ceramic (silicon carbide). It has a honeycomb-like structure with a large number of channels that are alternately closed at their ends so that the exhaust gas flow is forced to pass through the fine pores of the filter walls, the gaseous substances can pass through without any problems, whereby the much larger soot particles and other solids are retained on the partition walls deposit on the wall surfaces.



FIGURE 2. Diesel Particulate Filter

### 4. CATALYTIC CONVERTER

As emission regulations have tightened, the complexity of the catalytic converter system has increased. Meeting the demands of tightening legislation may require increased converter volume, translating into the use of multiple catalytic converter elements within a vehicle exhaust system.

Components used in this work consisted of Cordierite flow-through monoliths wash coated with alumina and platinum catalyst as well as Pt/Pd which provides low temperature T50 values for CO and HC. But in the case of under floor catalytic converter, which is widely used for many years because of convince of packaging as its catalyst. In order to reduce this delay, and to increase the efficiency of the catalyst at low temperature, the improvement in wash coat formulation is introduced with the help of new precious metals such as Pt/Pd

Oxidation of carbon monoxide to carbon dioxide:

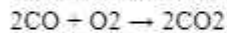

Oxidation of hydrocarbons (unburned and partially burned Fuel) to carbon dioxide and water:

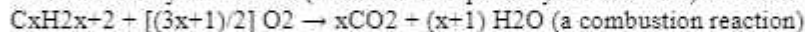

### 5. TEST PREPARATION

The setup consists of single cylinder, four stroke, Diesel engine connected to eddy current dynamometer for loading. It is provided with necessary instruments for combustion pressure and crank-angle measurements. These signals are interfaced to computer through engine indicator for PV diagrams. Provision is also made for interfacing airflow, fuel flow, temperatures and load measurement. The set up has stand-alone panel box consisting of air box, fuel tank, manometer, fuel measuring unit, transmitters for air and fuel flow measurements, process indicator and engine indicator. Rota meters are provided for cooling water and calorimeter water flow measurement.

When the engine is started the diesel is supplied to the combustion chamber directly and the ethanol is supplied to the engine by Time Valve at different time intervals like 2millisec, 3 millisec, 4 millisec, 5 millisecond using manifold injection with help of ECU. The emission of the engine is tested for different loads at different time intervals.

| PROPERTIES                                    | ETHANOL               | Diesel |
|---|-----------------------|--------|
| Density ( $\text{kg/m}^3$ )                   | 789                   | 816    |
| Kinematic viscosity ( $\text{m}^2/\text{s}$ ) | $1.52 \times 10^{-6}$ | 2.20   |
| Flash point ( $^{\circ}\text{C}$ )            | 12.7                  | 48     |
| Fire point ( $^{\circ}\text{C}$ )             | 63                    | 55     |
| Calorific value (MJ/kg)                       | 29.78                 | 45.66  |
| Pour point                                    | -10                   | -9     |
| Total acidity (mg of KOH/g)                   | 0.56                  | 0.38   |

## 6. CONCLUSION

This paper shows that the emissions can be reduced by injecting the ethanol fuel with diesel at certain time intervals and using catalytic converter, diesel particulate filter. Injecting ethanol at different time intervals 2ms, 3ms, 4ms and 5ms are suitable for engine operations. Ethanol as to be prepared by starch-based crops by dry-wet-mill process. The use of EGR and various After Treatment devices (AFT) like Catalytic Convertors (CC), Diesel Particulate Filter (DPF) and DOC are required to reduce the emission further. And ethanol can also be used as a substitute for SI engines but needs greater modification in carbonation injection system. By using only ethanol and diesel fuels only NO<sub>x</sub> can be reduce, if the AFT devices are used HCs and CO can also be reduced.

## REFERENCES

- [1].The effect of using ethanol as additive on the combustion and emission of direct injection diesel engine. <https://doi.org/10.1016/j.renene.2016.09.044>.
- [2].Aditya Srinath, Antochan Sony Aerath and G Kasiraman, Experimental Investigation On The Usage Of Ethanol and DEE as Additives In a CI Engine, International Conference On Advances In Thermal Engineering and Application(2017).
- [3].Gurkamal Nain singh and Rabinder Singh Barj, Experimental Study Of Filtration Behavior Of Diesel Particulate Filter in a Diesel Engine to meet BS-VI Emission Norms in India,(2019).
- [4]. Chunde Yao ,C S Cheung. Effect of diesel/ethanol compound combustion on diesel engine combustion and emission. <https://www.researchgate.net/publication/239363375>.
- [5]. The effect of biodiesel and bioethanol blended diesel fuel on nanoparticles and exhaust emission from CRDI diesel engine. <https://www.researchgate.net/publication/228733340>

## EXPERIMENTAL STUDIES ON OSCILLATING HEAT PIPE USING NANO FLUIDS

Prerana A. M.<sup>1</sup>, Suhas H.J. <sup>1</sup>, Sachin Gharabude <sup>1</sup>, Keerthana M <sup>1</sup>, Parashuram A. K.<sup>2</sup>

<sup>1</sup>Students, <sup>2</sup>Assistant Professor

Department of Mechanical Engineering, K S Institute of Technology, Bangalore-560109, Karnataka, India

### ABSTRACT

*A heat pipe is a device that employs phase transition to transfer heat between two interfaces. Oscillating heat pipe (OHP) is the new and developing technique under thermal management domain of electronic devices. The main applications of oscillating heat pipes are to cool the electronic chips in the electronic devices, Spacecraft thermal control systems, and many more. The main objectives of this research is to carry out a detailed experimental studies on a Multi Turn Closed Loop Oscillating Heat Pipe, To study the heat transfer and fluid flow characteristics with pure working fluids and Nano fluids and to conduct the parametric studies with pure and nano fluid under varying heat input. In the present work, transient and steady state experiments are conducted on a multi turn closed oscillating heat pipes. In the present work, evaporator and condenser temperatures are measured and tracked with the help of a data logger. The parameters such as condenser and evaporator temperatures, the overall heat transfer coefficient and thermal resistance are assessed. The experimental results reveal that SWCNT particle-based Nano fluid is surpass the base fluid considered in terms of higher heat transfer coefficient and lower thermal resistance. The Multi Loop Oscillating Heat Pipe is found to operate on a higher standard for all heat loads & working fluids considered.*

**Keywords:** Oscillating heat pipe (OHP), Single Walled Carbon Nano Tube (SWCNT), Nanofluid, Thermal performance.

### 1. INTRODUCTION

Oscillating heat pipe (OHP) is the new and developing technique under thermal management domain of electronic devices. Numerous cooling methods are procured to cool the electronic devices. Oscillating Heat Pipe is being explored for electronic cooling devices with potential results. Although the conventional heat pipes are excellent heat transfer devices, their relevance is mainly restricted to transferring small amount of heat over moderately short distances.

Oscillating heat pipe (OHP) is a passive two-phase heat transfer device, which is a peculiar category of capillary tubes. It has been invented by Akachi [1-3], it exhibits self-sustained oscillation of the working fluid and phase change phenomenon leading to enhanced heat transfer. Due to its light weight, simple design, very fast response low fabrication cost at higher heat loads, OHPs have been contemplated as one of the compact heat transfer devices for innumerable cooling applications such as heat exchanger and space application, electronics cooling, etc. Since the last two decades, many investigators have examined its thermal performance theoretically and experimentally. These experimentations reveal that the Closed Loop Oscillating Heat Pipe (CLOHP) function is strongly affected by many factors including geometrical, operational and physical parameters.

Additionally, it is revealed that the problem of two-phase flow oscillation in closed loop Oscillating heat pipe is very complex because of many unbalanced variables and complications of thermo-hydrodynamic operational features. At the same time, some visual studies have been performed using glass tube to understand the operational characteristics and extensive progress has been also accomplished in these Attempts [4]. Recently, improving thermal characteristics of CLOHP has become a challenge and debating topic among researchers due to increasing heat load and diminution of electronic devices. Based on prevailing experimental results the working fluid is the most important factor in the CLOHP. Simultaneously, Nano fluids are regarded as advanced heat transfer fluids in heat transfer devices. The nanoparticles of size about less than 100nm are blended in the base fluid to form Nano fluid. The heat transfer characteristic of the base fluid is improved drastically due to increased surface area. In 1995, this perception was first proposed by Choi. Since Then, some researchers concentrated on the heat transfer performance of Nano fluids such as, viscosity and thermal conductivity in flow with phase change and also, single-phase flow.

Presently, the nanofluid, considered as a working fluid in the electronic device, is an arising topic. In 2004, Tsai et al. [5] discovered application of nanofluids in the Conventional heat pipes employing gold nanoparticle solution and there was a considerable reduction observed in thermal resistance of heat pipe with nanofluid as compared to water. In 2006, Ma et al. [6] performed experiments under diverse operating temperatures and heat powers using water-based diamond nanofluid in the CLOHP.

They testified that the nanofluid could commendably improve heat transfer due to eventuality of strong oscillatory motion of flow. Lin et al. [7] noticed thermal enhancement of the heat pipe with by using water-based silver nanofluid at very low mass concentration.

Experiments are executed on two phase flows of the CLOHP using Nano fluid and DI water [8, 9]. Ji et al. [10] observed improvement in the start-up implementation of CLOHP due to alumina nanofluid. Jian Qu et al. [11] pointed out progress or decline of the CLOHP performance due to different nanoparticle deposition conduct with different nanofluids. A similar decline of heat pipe (thermosyphon) performance was found by Khandekar et al. [12]. It is perceived from pertaining literatures [5-12] that the improvement/decline of boiling performance in the heat pipes is because of change in surface property. The insignificant amount of the nanoparticle blended in the base fluid cannot essentially increase the thermal conductivity of the working fluid. Nonetheless,

the fluctuations of the particles in the working fluids might have supplementary contribution in enhancement of thermal performance of the CLOHP [6]. From the collected works [13–15], it is felt that the study of Nano fluids is still promising and won the whole, the understanding of two-phase flow heat transfer with the CLOHP is in the initial stage. Hence, experimental researches in both engineering and fundamental systems are needed.

Further, it is pointed that insufficient amount of work has been accomplished with use of metal nanoparticles in the CLOHP. Therefore, the current work aims at experimentally researching the thermal characteristics of the device using SWCNT Nano particle-based Nano fluids. Results of the current review are expected to help us to get familiar and design more proficient Nano fluid-charged CLOHP's functioning.

## 2. EXPERIMENTATION

### 2.1 Material Selection & Fabrication

The basic components that are used in OHP are copper tubes, borosilicate glass tubes, silicon rubber tubes for joining end to end of a glass and copper pipe and a thermocouple is used to measure the heat. Copper is used as the tube material since it is an excellent conductor of heat. The tube is bent into a multi loop U turn with a radius of 35mm. The glass tube is attached between the U turn copper tubes as we can clearly see the pulsation of the fluid inside the glass tube and it also acts as the adiabatic section. The tube is made of borosilicate glass, which can resist temperature up to 1200°C. Silicon rubber tubes are used as the connectors between glass and copper tubes. They can resist temperatures up to 400° C. Four 'K-type' thermocouples are used for temperature measurement. Two thermocouples are connected in the evaporator section and the other two at the condenser section at equal distances. A four-channel digital temperature indicator is used to record the temperatures at different locations. This is fed to the computer visuals using the TracerDaq software which displays the recorded temperature. A coil wound heater attached to evaporator section acts as the source of heat input, and the temperature can be varied with the help of a regulator. Water is used in condenser section to cool down the working fluid. The experimental setup is worked with two working fluids viz., water, and SWCNT based Nano fluids. The Working fluid is carefully measured for 60% fill ratio and is injected into the copper heat pipe using a syringe. Then the heat input of 25W,30W,35W,40W is given and to avoid heat loss at the evaporator section glass wool is kept as a heat insulation material and the experiment is kept under observation for 30min and the corresponding values are recorded.



FIGURE 1. OHP experimental setup

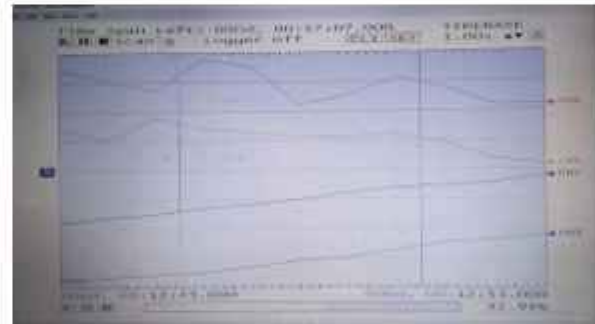

FIGURE 2. Values obtained from datalogger

### 2.2 Experimental Procedure

Before conducting the experiment, it is ensured that there is no fluid inside the tubes. The required amount of measured working fluid is then injected into the copper tube through a syringe by opening one end of the valve such that the fluid enters the evaporator section. Then the valve is closed using the silicon tube and hence it forms a closed loop. Then the display unit is switched ON and the required wattage(25W,30W,35W,40W) is set. The transient experiments are conducted and the various temperatures are recorded through a datalogger. The output of the temperature data logger with the help of the software is monitored in the computer. The experiments are performed for a duration of 30min each.

The colloidal solution of SWCNT particle Nano fluids is prepared by using water as base fluid and experimentation is carried out by varying the heat input as well as by varying the fill ratio. The values obtained will be plotted by a graph of thermal resistance with heat input and heat transfer coefficient with heat input. A typical output from the data acquisition system is as shown below.

### 3. RESULTS AND DISCUSSION

Transient experiments have been conducted with the working fluids i.e., water and SWCNT based Nano fluid and variations of temperature with time are recorded. The experiments are conducted for a duration of 30min.

Fig 3 shows the variation of temperature difference between evaporator and condenser with time at heat inputs for 25W, 30W, 35W and 40W respectively for water at a fill ratio of 60%. It is observed that the temperature difference between evaporator and condenser is considerably less at lower heat input of 25 W and it increases for increase in wattage. For more accurate results we have conducted two trials for every wattage of each fluid.

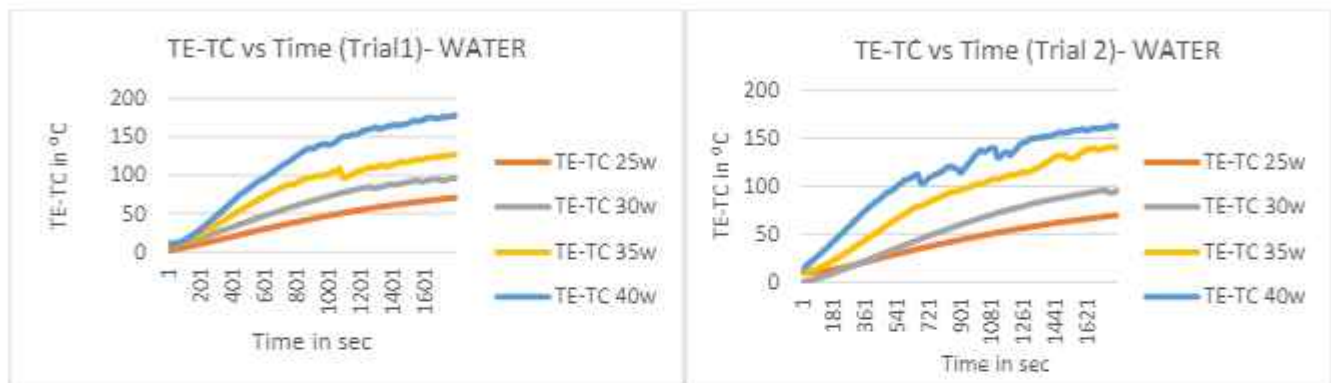

FIGURE 3. Temperature Difference (TE -TC) Plot for water

Fig 4 shows the variation of temperature difference between evaporator and condenser with time at different heat inputs for SWCNT at a fill ratio of 60%. It is observed that the temperature difference between evaporator and condenser is considerably less at lower heat input of 25 W and gradually increase with increase in heat input.

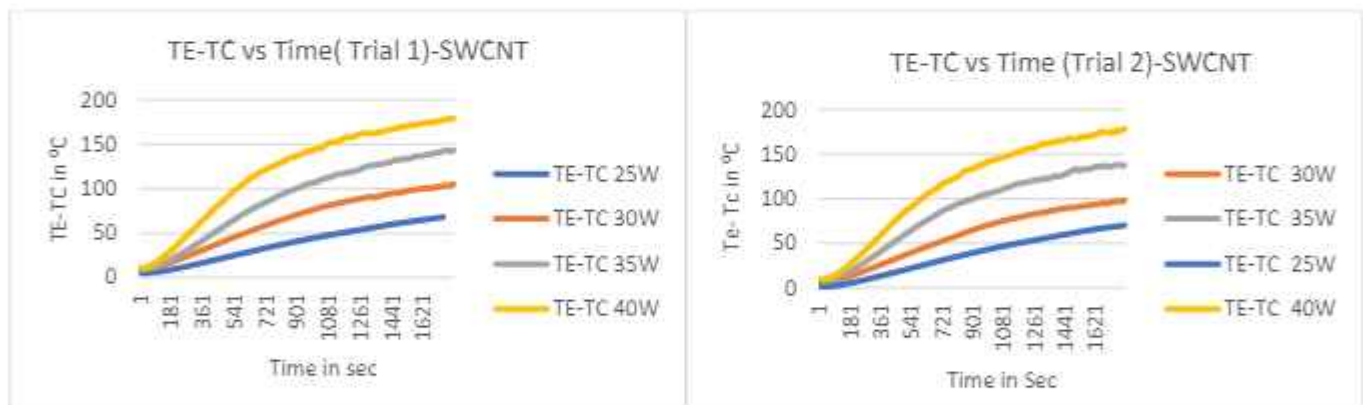

FIGURE 4. Temperature Difference (TE-TC) Plot for SWCNT

Finally, the effectiveness of the heat pipe is indirectly brought in terms of thermal resistance and convective heat transfer coefficient.

#### CALCULATIONS

The capillary tube material used in the evaporator and condenser sections are copper material. The specifications of the capillary tube are inner diameter of 1.5 mm and outer diameter of 3 mm. The total length of the closed loop oscillating heat pipe is 2040mm. The experiments are conducted in vertical position for different heat input in steps of 5W from 25W to 40W.



Length of the Heat Pipe = 206 cm

Diameter = 2 mm

$$Vf = \frac{\pi}{4} * d^2 * L$$

$$Vf = \frac{\pi}{4} * [0.002]^2 * 2.06$$

$$Vf = 6.4 * 10^{-5} \text{ m}^3$$

$$Vf = 64 * 10^6$$

$$Vf = 64 \text{ cc}$$

$$As = \pi DL$$

$$= \pi * 0.002 * 2.06$$

$$As = 0.0129 \text{ m}^2$$

The thermal resistance is computed as,

$$R_{th} = \frac{T_E - T_C}{Q} \text{ [}^\circ\text{C / W]} \text{ -----(1)}$$

Convective heat transfer co-efficient is given by

$$h = \frac{Q}{As * (T_E - T_C)} \text{ [W / }^\circ\text{C m}^2\text{]} \text{ -----(2)}$$

Where,

TE = Evaporator temperature in  $^\circ\text{C}$

TC = Condenser temperature in  $^\circ\text{C}$

Q = Heat input in W

As = Surface area of the condenser section of heat pipe in  $\text{m}^2$

Rth = Thermal resistance in  $^\circ\text{C / W}$

h = Heat transfer coefficient in  $\text{W / }^\circ\text{C m}^2$

Fig.7 &8 shows the variation of thermal resistance and heat Transfer coefficient with heat load at steady state for Water and SWCNT at a fill ratio of 60%. It is observed that the thermal resistance decreases with increase in heat input & heat Transfer coefficient increases with increase in heat load for both Water and SWCNT.

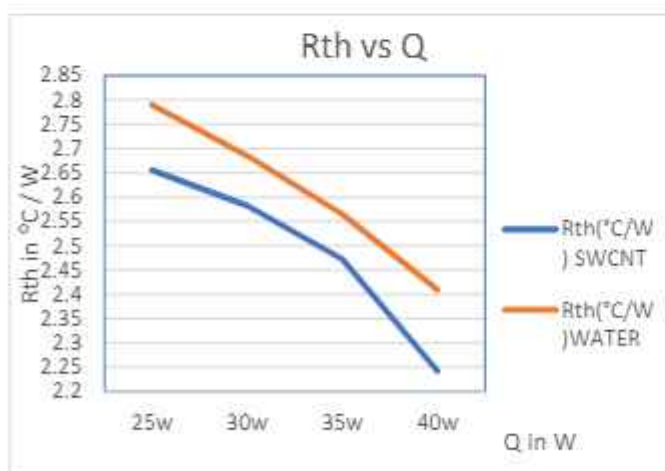

FIGURE 7. Thermal Resistance vs heat input

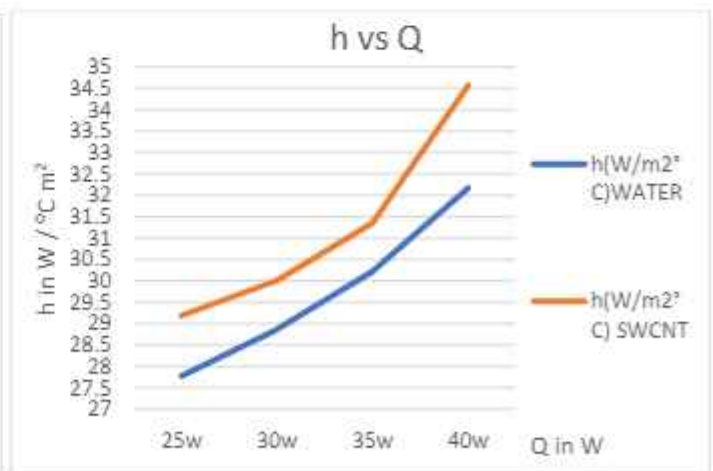

FIGURE 8. Heat transfer coefficient vs heat input

| Q (W) | Rth( $^{\circ}\text{C}/\text{W}$ )<br>WATER | h( $\text{W}/\text{m}^2\text{C}$ )<br>WATER |
|-------|---|---|
| 25W   | 2.79  | 27.78                                       |
| 30W   | 2.685                                       | 28.864                                      |
| 35W   | 2.565                                       | 30.22                                       |
| 40W   | 2.4097                                      | 32.169                                      |

TABLE 1: Experimental values of Water

TABLE 2: Experimental values of SWCNT

| Q (W) | Rth( $^{\circ}\text{C}/\text{W}$ )<br>SWCNT | h( $\text{W}/\text{m}^2\text{C}$ )<br>SWCNT |
|-------|---|---|
| 25W   | 2.6554                                      | 29.191                                      |
| 30W   | 2.5825                                      | 30.01                                       |
| 35W   | 2.472                                       | 31.35                                       |
| 40W   | 2.242                                       | 34.57                                       |

#### 4. CONCLUSION

In the current investigation, the experimental research is executed on a Multi Turn Loop OHP. The effects of working fluid, heat input and fill ratio on the performance of OHP are analyzed.

Following conclusions are made from the experimentation:

- The change of temperature between condenser and evaporator with time is found to be recurring.
- The difference in temperature between evaporator and condenser at constant state is found to be less for SWCNT in comparison to water.
- SWCNT is observed to be more suitable working fluid for OHP operation under varying operating conditions.
- The results show that SWCNT has more heat transferring capacity with less temperature difference and less thermal resistance. Thus, SWCNT can be considered as more suitable working fluid for OHP functioning.

#### REFERENCES

- [1]. Akachi, Structure of a heat pipe, US Patent # 4991041, 1990.

- [2] H. Akachi, Structure of micro-heat pipe, US Patent # 5219020, 1993.[3] H. Akachi, F. Pola's\_ek, P.S\_tulc, Pulsating heat pipes, in: Proceedings of the Fifth International Heat Pipe Symposium, Melbourne, Australia, (1996) 208–217.
- [4] S. Khandekar, P. Charoensawan, M. Groll, P. Terdtoon, Closed loop pulsating heat pipes -Part B: visualization and semi-empirical modelling, *Appl. Therm. Eng.* 23 (2003) 2021–2033.
- [5] C.Y. Tsai, H.T. Chien, P.P. Ding, B. Chan, T.Y. Luh, P.H. Chen, Effect of structural character of gold nanoparticles in nanofluid on heat pipe thermal performance, *Mater. Lett.* 58 (2004) 1461–1465.
- [6] H.B. Ma, C. Wilson, Q. Yu, K. Park, S.U.S. Choi, Murli Tirumala, An experimental investigation of heat transport capability in a nanofluid oscillating heat pipe, *J.Heat Transfer* 128 (2006) 1213–1216.
- [7] Y.-H. Lin, S.W. Kang, H.L. Chen, Effect of silver nano-fluid on pulsating heat pipe thermal performance, *Appl. Therm. Eng.* 28 (2008) 1312–1317.
- [8] N. Bhuwaketkumjohn, S. Rittidech, Internal flow patterns on heat transfer characteristics of a closed-loop oscillating heat-pipe with check valves using ethanol and a silver nano-ethanol mixture, *Exp. Therm. Fluid Sci.* 34 (8) (2010) 1000–1007.
- [9] Q.-M. Li, Jiang Zou, Zhen Yang, Yuan-Yuan Duan, Bu-Xuan Wang, Visualization of two-phase flows in nanofluid oscillating heat pipes, *J. Heat Transfer* 133(2011): 052901-1.
- [10] Y. Ji, H.B. Ma, Fengmin Su, Guoyou Wang, Particle size effect on heat transfer performance in an oscillating heat pipe, *Exp. Therm. Fluid Sci.* 35 (2011) 724–727.
- [11] J. Qu, Huiying Wu, Thermal performance comparison of oscillating heat pipes with SiO<sub>2</sub>/water and Al<sub>2</sub>O<sub>3</sub>/water nanofluids, *Int. J. Therm. Sci.* 50 (2011) 1954–1962.
- [12] S. Khandekar, Yogesh M. Joshi, Balkrishna Mehta, Thermal performance of closed two-phase thermosyphon using nanofluids, *Int. J. Therm. Sci.* 47 (2008)659–667.
- [13] Lixin. Cheng, Lei. Liu, Boiling and two phase flow phenomena of refrigerant based nanofluids: fundamentals, applications and challenges, *Int. J.Refrigeration* 36 (2013) 421–446.

## DESIGN AND FABRICATION OF GYM EQUIPMENT FOR POWER GENERATION

Ashish Vilas Jadhav<sup>1</sup>, Akhiljith KS<sup>1</sup>, Bharath R<sup>1</sup>, Jagruth S<sup>1</sup>, Dr. Girish TR<sup>2</sup>

<sup>1</sup>Students, <sup>2</sup>Associate Professor

Department of Mechanical Engineering,

K S Institute of Technology, Bangalore-560109, Karnataka, India

### ABSTRACT

*This paper deals with alternate source of energy, since there is a scarcity of conventional energy resources now a days, there is a need for developing and usage of renewable energy resource. In this work an attempt has been made to convert the energy released by people when they are doing the work out. Here human acts as the power source and the gym equipment acts as both exercise equipment and source of power generation. Here reciprocating motion of the equipment is converted in to rotary motion using rack and pinion arrangement. Further the rotary motion is converted in to electrical energy by the use of alternators.*

**Keywords:** Source of energy, conventional, renewable, gym equipment, Rack and pinion.

### 1. INTRODUCTION

The renewable energy resource has becoming an progressive subject among the research and scientific community. The idea is to build an energy resource that can generate renewable source of energy from day to day activities. The novel work is intended to covert the mechanical energy into electrical energy from the gym equipment when people start doing the workouts. The converted electrical energy can be used to power lights, charging of cell phones and other small applications which require less power. Further these systems can be improved for large scale power generation with minimum cost and marketability. In this project provision has been made for the efficient and controlled power storage. The gym equipment is connected to dynamo motor which converts kinetic energy in to electrical energy. The converted electrical energy can be used to power the lamps, charging etc. Most of the fitness center equipped with treadmills, rowing machines, stationary bikes, pull up machine etc to burn calories. Power produced will be dissipated as heat energy. This heat energy if it is captured and used as an alternate source of energy will be good for environment and reduce the consumption electricity from the primary source. The process of capturing, converting and storing of this energy is called Energy Harvesting(EH). There are different methods available of converting in to electrical energy using gym equipment. The various gym equipment are Treadmill, pull up machine, bicycle etc.

#### 1.1 Tread Mill

Tread mill equipment are used both in gym and home. Tread mill consists of path like structure which rotates and shift, so that the person can walk and run like in out door. He can also set the speed according to his requirement and capacity. The burnt calories can also be converted in to electrical energy and even it has been implemented in many houses and gym centers. It can produce up to 95 Watts of power in average which can be used for many applications. Fig 1 shows the setup of tread mill in a gym.



FIGURE 1. Tread mill in a Gym

## 1.2 Pull up machine

Another very important equipment in gyms are pull up machines where people try to lift heavy loads when they do the exercise. These equipment are not widely used since power generation is relatively less as compared with other equipment. Power generation is done when the loads are lifted. Conversion of energy from mechanical to electrical is done by attaching rack and pinion arrangement or with sprocket. Fig 2 shows the gym pull up equipment.



FIGURE 2: Gym pull up equipment

## 1.3 Stationary bicycle

Stationary bicycles are one of the very important equipment in gyms. These bicycle are used for cardio vascular exercises for both men and woman. It is one of the best exercise for heart. These stationary bikes are coupled with electrical generator which is used in the gym are called eco bikes. The mechanical work I.e pedalling of the pedals in turn rotates the wheel attached to it, these wheel is connected to electrical generator. These types of bicycles are used in modern gyms. Fig 3 shows the stationary bicycle used in the gym.



FIGURE 3. Stationary bicycle used in gym

## 2. CONSTRUCTION

### 2.1 Energy conversion equipment for Gym machine

In this project an attempt has been made to design and fabricate electricity generation from pull up machine. We are expecting an output of 55 – 60 watts, this can be used lamps, an amplifier and an ipod charger. This system consists of many sub systems that will work collectively for the efficient production of electric power. The first sub assembly consists of elements which converts kinetic energy from pulling to generator. The second system consist of electrical generator, this sub system transfers rotational movement in to output AC voltage. The next sub system converts AC power to DC, This DC power is stored in batteries. The stored energy is sent to the inverter which converts 12V DC to 12V AC. By using step up transformer the 12V AC is stepped to 230V.

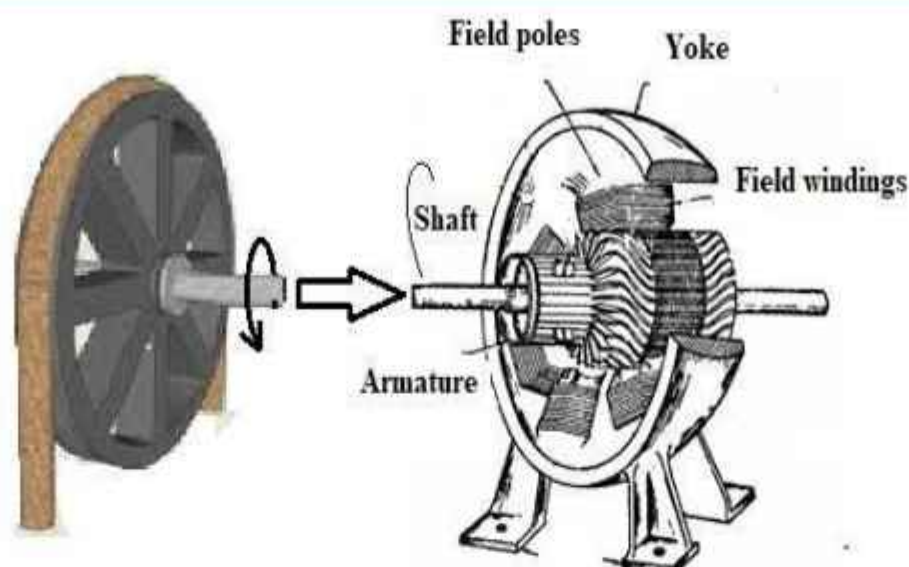

FIGURE 4. Output of pulley connected to alternator

### 3. METHODOLOGY

- Initially the frame of the body has been set up which contains the major components of the model. The frame has been taken from gym(not in use) which is converted to our requirement.
- Bearings are provided at proper position which carries the main shaft which is then supported in the frame. Pulleys are added(in between) to reduce the human effort.
- A wire rope is used to connect between the handle at one end and the other end is attached to dead weight through pulley.
- Dynamo along with pulley is also supported on the frame which is connected to driver pulley using rope.
- The electrical connections has been made which is connected to dynamo .
- The conversion of AC from the dynamo to DC is done using rectifier circuit.
- The output from the rectifier is connected to 12V battery where it is stored.
- When people start using the equipment for work out the lifting of weight causes the rotation of the main shaft which is then connected to dynamo which produces electricity and it is stored in batteries.

### 4. COMPONENTS USED AND ADVANTAGES AND DISADVANTAGES

The main components used in this project work includes frame, handle. Bearings, shafts, pulleys, dynamo, batteries and dead weights. Some of the advantages include less maintenance cost, avoids any fossil fuels, environment friendly, human fitness and electrical energy can be stored in batteries.

The major disadvantages include , as compared with bicycle or treadmill less power conversion, since more mechanical linkages there is a possibility of failure of the assembly, weight of the structure and sub structure is high so it is difficult to transport, additional attachments are more, the initial cost is bit high.

### 5. CONCLUSIONS AND SCOPE FOR FUTURE WORK

#### CONCLUSIONS

- The design and fabrication of innovative gym equipment to convert kinetic energy in to electrical energy has been carried out.
- Storage of energy is very important and necessary part of the project work, it has been ensured the stability of the system is maintained. These models vary in complexity and accuracy and therefore the model chosen must match the application for which it is needed
- These systems can be incorporated in many places and if it is operated regularly it can convert sufficient amount of energy.
- It will be very helpful for the rural areas. In this day where the world is challenged to be more responsible in its sourcing of electrical power, the method of human power generation could be a solution that also helps mitigate the issue of obesity and overweight.

### Scope for Future Work

- By having more number of dynamo more power can be converted in to electrical energy
- It can be adopted with variable gear ratio can be adopted
- It is possible to add fly wheel , speed control devices and voltage protection devices so that the system is full proof.
- If the system is installed in gym centres where more and more equipment's then more energy can be converted and power generation can be done in a large scale.

### REFERENCES

- [1] M. Musharraf, Ifrah Saleem, Farhat Iqbal, Energy Generating Gymnasiums Machines for Renewable, Sustainable and Green Energy, International Research Journal of Engineering and Technology, Vol. 5(12), 2018, Pp. 153-160.
- [2] Roshan Ojha, Rahul Raj, Shaaravan Kumar, T.Hari prasadh, Naveen Kumar, KS Badarinarayan, Power generation by gym pull up, International Research Journal of Engineering and Technology, Vol. 5(6), 2016, Pp. 1297-1299.
- [3] Sourabh Borchate, Amit Gaikwad, Ajay Jadhav, Prasad Dhage, Design of Treadmill to Generate Electricity by using Mechanical Energy, International Conference on Ideas, Impact and Innovation in Mechanical Engineering, Vol. 5(6), 2017, Pp. 498-505.
- [4] Madhup Kumar, G S Mundada, Energy Harvesting from Gym Equipments, International Journal of Innovative Research in Electrical, Electronics, Instrumentation and Control Engineering, Vol. 5(7), 2017, Pp. 127-131.

## DESIGN AND FABRICATION OF MIST IRRIGATION SYSTEM

<sup>1</sup> Sumanth Kumar R, <sup>2</sup>Kunal Sagar S, <sup>3</sup>Nikhil Singh K, <sup>4</sup>Prajwal S, <sup>5</sup> Dr. Nirmala L

<sup>1234</sup> UG-students

<sup>5</sup>Associate Professor

Department of Mechanical Engineering  
K.S. Institute of Technology Bangalore -560109

### ABSTRACT

*Irrigation or water use for agriculture is the biggest water consumer. Reducing water use for irrigation means significantly to water saving. Drip and mist irrigations are methods of water application which consume water more efficiently and more agriculture products produce from same amount of water. This project aimed to assess performance of mist irrigation to supply irrigation water for sapling. The vegetables cultivated were spinach, mustard, and water spinach. The indicators employed were discharge, uniformity, dan water productivity. The uniformity was measured using distribution uniformity (DU) and Christiansen uniformity index (CU).*

**Keywords:** Irrigation, Water, Temperature, Agriculture, Mist irrigation, nozzle.

### 1. INTRODUCTION

Irrigation is a very essential part of agriculture especially when there is inadequate supply of water through rain fall. Therefore, there should be an easy way to irrigate the plants [1]. In many areas of the planet, the quantity of rainfall isn't capable to meet the moisture requirements of crops. Hence Mist irrigation is an important improvement over convenient to other irrigations. It stimulates natural rainfall by breaking water droplets within the sort of rain uniformly over the land surface when needed at required quantity during a uniform pattern, this type of irrigation not only helps is propagation of right amount of water to the plant but also to control the temperature around it, this system is specific for a crop and hence its usage is limited [2].

Though there are various processes available for developing FGMs, an cost effective method for production of the bulk FGMs, liquid metallurgy route with centrifugal force method is preferred for the reason that, it is economically feasible and capable to produce large size products. Centrifugal casting is found to be the simplest and cost effective technique for producing large size engineering components, such as pipes, shafts, bushings. This project aims to fabricate horizontal centrifugal casting machine and also develop Al6061 alloy using fabricated machine.

Proper scheduling of irrigation is critical for efficient water management in crop production, particularly under conditions of water scarcity. The effects of the applied amount of irrigation water, irrigation frequency and water use are particularly important. To improve water efficiency there must be a proper irrigation scheduling strategy. So this project devices design and fabrication of mist irrigation system. This process could thus eliminate the excess piping required in case of the drip irrigation and sprinkler irrigation systems [3]. The mist irrigation system is very efficient and saves both manual labour and water consumption.



FIGURE 1. Mist from Nozzle





FIGURE 2. Lay out for testing mist irrigation

Nozzles were rated at 1/8 inch of water per hour at 40 pounds pressure. Later in the season it was obvious that the nozzles were spaced too closely; therefore every other nozzle was removed for the remainder of the season except in the west and east border rows. Four nozzles were also left at the south end of each lateral.

Nozzle: A durable, fail-safe nozzle is an indispensable part of an effective mist system. You don't want nozzles leaking...

Compression fittings: Compression fittings are sturdier pieces that connect your water-brining hose to water-misting...

Tube or hose: The water-carrying tube is the most easy-to-use and economical part of the mister system. Choose a 1/4-inch...

Filter: attaching a mesh filter to the spigot that feeds your mister system is mandatory.

## 2. MATERIALS AND METHODOLOGY

Cauliflower seeds of the variety "lettuce seeds" were seeded on may17 2022, after 10 days the seedlings were transplanted to wooden flats 2.5 by 2.5 inches apart. On may30th the plants were planted in the field and watered immediately after transplanting. Rows were spaced feet apart and the plants within the rows. A mist system was installed over the plots so that mist could cover the entire area.

The main water line on the north side of the plots ran in an east-west direction, Mist lines were placed over the rows. Running south from the main line. This line was 3 feet long and 0.8cm in diameter. The three lateral lines containing the mist nozzles were 0.3cm in diameter and 9 feet long. The lateral lines on the west side of the plot were placed feet apart. The next lines were placed the two lines on the east side of the plot were placed feet apart.

The analysis consisted of parameters, namely discharge, distribution uniformity, Christiansen uniformity index, vegetable water productivity, and biomass water productivity. Discharge received of each box were calculated using equation

$$Q=V/t$$

Where Q was discharge, V was volume of irrigation water collected on each box, and t was duration of each operation



FIGURE 3. Germination of seeds in the selected area

### 3. RESULTS AND DISCUSSION

This project tried to assess the performance of water saving irrigation. The water saving meant the irrigated farming produce more harvest from a unit of water consumption. this projects also aims to control the temperature around the plants so that the plant is at optimum condition no matter the natural temperature outside. the table 1 shows the water discharge compare with drip irrigation and mist irrigation .

TABLE 1. Water discharge compare with drip irrigation and mist irrigation

| Type            | Minimum discharge, $q_{min}$ | Maximum discharge, $q_{max}$ |
|-----------------|------------------------------|------------------------------|
| Drip irrigation | 4.25 ml/sec                  | 8.25 ml/sec                  |
| Mist irrigation | 0.81 ml/sec                  | 1.78 ml/sec                  |

TABLE 1: Water productivity ( $kg/m^3$ )

| Type            | indicator                    | spinach        | lettuce        |
|-----------------|------------------------------|----------------|----------------|
| Mist irrigation | Vegetable water productivity | $0.8360kg/m^3$ | $0.8250kg/m^3$ |

### 4. CONCLUSION

This project provides a significant increase in the advantages to traditional irrigation methods. It provides the moisture to the plant as well as to the atmosphere surrounding the plant there by maximizing the water usage. It uses various calculation and equipment to reduce water consumption and excess pipeline. Thus this is the complete improvement to the traditional agricultural irrigation methods and also to most of the automated methods such as manual irrigation, drip irrigation, spray irrigation system etc

#### Future Scope

The future scope of this project can be made compatible with automated smart irrigation system is designed so that the user has full control and almost no manual work. it can be made into large scale agricultural fields, it also helps in controlling crop control during droughts and other drastic climate changes. It can also help in yielding good quality seasonal or non-seasonal crops/plants for modern agriculture, a smart irrigation system is one of the best techniques that give more production in minimum duration. To many extend, this smart irrigation system is designed and fully automated to minimize manual handling in agriculture.

## ACKNOWLEDGEMENTS

We would like to extend our sincere thanks to all those who played a role in the completion of this project. Firstly, we are highly indebted to "K S Institute of Technology" Bangalore for their constant supervision and support. we are immensely grateful to all those involved in this project as without their inspiration and valuable suggestion it would not have been possible to develop the project within the prescribed time period.

## REFERENCES

- [1] Design and Implementation Of Automatic Plant Irrigation System Dr.P.Sengottuvel, Dr.J.Hameed Hussain, Professor, Department of Mechatronics, Department of Mechanical BIST, BIHER, Bharath University, International Journal of Pure and Applied Mathematics Volume 118 No. 18 2018.
- [2] Agricultural Sprinkler for Irrigation System, Nirali Hemant Patel Student, Chintan Rajnikant Prajapati Student, Mechatronics G.H. Patel College of Engineering and Technology, International Journal of Engineering Research & Technology (IJERT) <http://www.ijert.org> ISSN: 2278-0181 Vol. 9 Issue 05, May-2020.
- [3] Smart Irrigation System S. Darshna, T.Sangavi, Sheena Mohan, A.Soundharya, Sukanya Desikan IOSR Journal of Electronics and Communication Engineering (IOSR-JECE) Volume 10, Issue 3, Ver. II (May - Jun.2015), PP 32-36.
- [4] Constantinos Marios Angelopoulos, Sotiris Nikolettseas, Georgios Constantinos Theofanopoulos, A Smart System for Garden Watering using Wireless Sensor Networks, MobiWac, October 31–November 4, 2011.
- [5] R.suresh, S.Gopinath, K.Govindaraju, T.Devika, N.Suthanthira Vanitha, GSM based Automated Irrigation Control using Raingun Irrigation System, International Journal of Advanced Research in Computer and Communication Engineering , Vol. 3, Issue 2, February 2014.
- [6] Rafael Muñoz-Carpena and Michael D. Dukes, Automatic Irrigation Based on Soil Moisture for Vegetable Crops, IFAS Extension, 2005.
- [7] K.N.Manjula B.Swathi and D.Sree Sandhya , Intelligent Automatic Plant Irrigation System.
- [8] G. Vellidis, M. Tucker, C. Perry, C. Kvien, C. Bednarz, "A Real-Time Wireless Smart Sensor Array for Scheduling Irrigation", National Environmentally Sound Production Agriculture Laboratory (NESPAL), 2007.
- [9] Anitha K, "AUTOMATIC IRRIGATION SYSTEM" 2nd International Conference on Innovative trend in Science, Engineering and Management, ISBN: 978-93-86171-10-8, 2016.

## EFFECT OF COMBINATION OF METHANOL INJECTION AND AFTER TREATMENT DEVICES ON DIESEL ENGINE EMISSION- A REVIEW

Santhosh M<sup>1</sup>, Omkar M V<sup>1</sup>, Sai karthik<sup>1</sup>, Bhaskar R<sup>1</sup>, Nagaprasad K S<sup>2</sup>

<sup>1</sup> Students, <sup>2</sup> Associate Prof

Department of Mechanical Engineering  
K.S. Institute of Technology Bangalore -560109

### ABSTRACT

*In Diesel/methanol compound combustion system (DMCC) the effect of methanol injection timings on combustion, performance and emissions were comprehensively investigated. The experimental results demonstrated that methanol injection timings plays important roles in combustion and emission control. Nox and soot emission were all decreased while HC and CO emission increased significantly. HC emission firstly increased and then decreased, while CO emission always increased.*

### 1. INTRODUCTION

Diesel engine is an internal burning engine where in start of the fuel is brought about by the raised temperature of the air in the chamber because of the mechanical pressure. Diesel engines works by packing just the air. This builds the air temperature inside the chamber to such a serious level that atomized diesel fuel infused into the burning chamber lights suddenly. In any case, the issue with diesel engine is its higher pace of contamination discharges. Among the fundamental contaminations Nitrogen Oxides (NOx), Carbon Monoxide (CO), Hydrocarbons (HC), Particulate Matter (PM), Carbon Dioxide (CO<sub>2</sub>), Sulphur Dioxide (SO<sub>2</sub>), aldehydes most unsafe poisons of diesel engine are NOx and PM. To adapt to the exacting discharge standard, green engine which diminishes exhaust emanation ought to be created. Execution of after-treatment frameworks like Diesel particulate channel (DPF), incite critical increase in outflows decrease were attempted. Diesel particulate channels (DPF) is the gadgets that truly catch diesel particulate matter in the Fumes line to Forestall the Delivery to the Climate.[1]

#### 1.1 Diesel Engine

A 4-stroke engine is a very common variation of an internal combustion engine. Most modern internal combustion-powered vehicles are 4-strokes, powered by either gasoline or diesel fuel. During engine operation, pistons go through 4 events to achieve each power cycle. The definition of an event is an up or down piston motion. Upon completion of the 4 events, the cycle is complete and ready to begin again. 4-stroke engines deliver a good balance of power, reliability and efficiency. When it comes to emissions, 4-strokes separate each event mechanically, which reduces unburned fuel emissions. It also separates oil from fuel, which significantly reduces carbon monoxide emissions. This combination of desirable traits has earned the 4-stroke the top spot in passenger vehicles today.[2]



FIGURE 1: CRDI Diesel Engine

#### 1.2 Diesel Particulate Filter

The particulate filter consists of a porous ceramic (silicon carbide). it has a honeycomb like structure with a large number of channels that are alternately closed at their ends so that the exhaust gas flow is forced to pass through the fine pores of the filter walls. The gaseous substances can pass through without any problem, where by the much larger soot particles and other solids are retained on the partition walls and deposit on the wall surfaces. [3].



FIGURE 2: Diesel Particulate Filter

### 1.3 Catalytic Converter

As emission regulations have tightened, the complexity of the catalytic converter system has increased. Meeting the demands of tightening legislation may require increased converter volume, translating into the use of multiple catalytic converter elements within a vehicle exhaust system.

Components used in this work consisted of Cordierite flow-through monoliths wash coated with alumina and platinum catalyst as well as Pt/Pd which provides low temperature T50 values for CO and HC, But in the case of under floor catalytic converter, which is widely used for many years because of convince of packaging as its catalyst LOT has 200 to 300s. In order to reduce this delay, and to increase the efficiency of the catalyst at low temperature, the improvement in wash coat formulation is introduced with the help of new precious metals such as Pt/Pd

Oxidation of carbon monoxide to carbon dioxide:

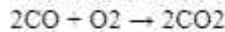

Oxidation of hydrocarbons (unburned and partially burned Fuel) to carbon dioxide and water:

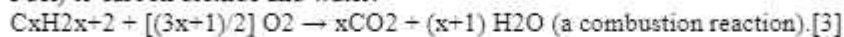

## 2. TEST PREPARATION

The setup consists of single cylinder, four stroke, Diesel engine connected to eddy current dynamometer for loading. It is provided with necessary instruments for combustion pressure and crank-angle measurements. These signals are interfaced to computer through engine indicator for PV diagrams. Provision is also made for interfacing airflow, fuel flow, temperatures and load measurement. The set up has stand-alone panel box consisting of air box, fuel tank, manometer, fuel measuring unit, transmitters for air and fuel flow measurements, process indicator and engine indicator. Rota meters are provided for cooling water and calorimeter water flow measurement.

When the engine is started the diesel is supplied to the combustion chamber directly and the ethanol is supplied to the engine by Time Valve at different time intervals like 2millisec, 3millisec, 4 millisec, 5 millisecond using manifold injection with help of ECU. The emission of the engine is tested for different loads at different time intervals.

TABLE 1: Properties of Methanol and Diesel

| Properties                   | METHANOL                                      | Diesel |
|------------------------------|---|--------|
| Density (kg/m <sup>3</sup> ) | 792   | 816    |
| Kinematic viscosity          | 0.792-7.37*10 <sup>-7</sup> m <sup>2</sup> /s | 2.20   |
| Flash point                  | 9   | 48     |
| Fire point                   | 36  | 55     |
| Calorific value (MJ/kg)      | 22.7  | 45.66  |
| Pour point                   | -12   | -9     |
| Total acidity (mg of KOH/g)  | 0.56  | 0.38   |

## 3. CONCLUSION

This paper shows that the emissions can be reduced by injecting the methanol fuel with diesel at certain time intervals and using catalytic converter, diesel particulate filter. Injecting methanol at different time intervals 2ms,3ms,4ms and 5ms are suitable for engine operations.

The use of various ATD devices like CC,DPF and DOC are required to reduce the emission further. and methanol can also be used as a substitute for SI engines but needs greater modification in injection system.

## REFERENCES

- [1] Dava , A.W. Ibrahim and O.Zhang, Naval Undersea Warfare Centre, Newport, RI, 'Control of diesel engine emissions by dilute oxidizer injection', Energy conversion engineering conference, 1996, IECEC96, Vol.3.
- [2] Dimitrios Theofanis Hountalas, George C. Mavropoulos, Theodoros Zannis, Sotirios Mamalis, 'Use of Water Emulsion and Intake Water Injection as NOx Reduction Techniques for Heavy Duty Diesel Engines', National Technical Univ. of Athens, SAE 2006-01-1414.
- [3] V. Sajith, C. B. Sobhan and G. P. Peterson, 'Experimental Investigations on the Effects of Cerium Oxide', Hindawi Publishing Corporation Advances in Mechanical Engineering, Nanoparticle Fuel Additives on Biodiesel, Volume 2010, Article ID 581407
- [4]Ho Teng, James C. McCandless and Jeffrey B. Schneyer, 'Thermochemical Characteristics of Dimethyl Ether- An Alternative fuel for compression-ignition engines', SAE 2001-01-0154.
- [5]Nagaprasad K.S., Prabhakara S.S., Shivakumar S., Dr. D. Madhu, "Water Injection in an Internal Combustion Engine- A Review", Proc. of National Conference on Recent Trends in Mechanical Engineering Sciences, RTIMES-08, SSIT, Tumkur,21-22 Feb 2008, page 12.

## DESIGN AND DEVELOPMENT OF DUAL LUG NUT FOR TIGHTENING AND LOOSENING OF FOUR WHEELER TYRES

S.N.Naga Nithesh<sup>1</sup>, Nikhil Bharadwaj.V<sup>1</sup>, Suhas.J<sup>1</sup>, Akshay.R<sup>1</sup>, Girish T R<sup>2</sup>

<sup>1</sup> Students, <sup>2</sup> Associate Prof  
Department of Mechanical Engineering  
K.S. Institute of Technology Bangalore -560109

### ABSTRACT

*The primary aim of the project is to design and fabricate a four-wheeler nut removing tool for tightening and removing of two nuts in single time. With the increase in use of cars on the road, the failure of tires has been increased considerably. Usually the cars are provided with spanner and a jack for the replacement of spare tires. Due to difficulties in maintaining uniform torque to remove nut and to save time. The main objective of the present work is to design and develop a single tool, which can be used for assembling and disassembling of nuts of tires in automobiles with minimum effort and time. Care has been taken for easy maintenance, storage and handling.*

Keywords: Four-wheeler nut, uniform torque, automobiles and tires.

### 1. INTRODUCTION

In the modern world four wheeler has become the essentials. These four wheelers are provided with T-nut wrench and jack to replace the tires when there is a puncture or any other problem in the tires. For women or teen the usage of jacks is a hard task. Once any problem arises with the vehicle to replace the tires which takes lot of time and effort. Drivers should have basic knowledge of tire replacement procedure if such problem occurs. In order to change the tire, one requires minimal skills. Virtually every car has a tire replacement tools such as the L-shaped nut remover and jack supplied by the manufacturer accurate tensioning of a screw is necessary. It is a fact that a huge effort is required to open a single nut of a car wheel and it will become a tedious task to open the wheel in extreme atmospheric conditions. It also creates problem when there is an emergency situation. Here is the solution to the problem mentioned above by Adjustable Unified Wheel Opener, it is a special tool designed for opening a wheel with ease. It is so designed that it can open all the four nuts of a car wheel in one time. And the most desired achievement is that, the total effort and time needed in the process is very less. It can open and also refit the wheel with the same tool. This project is intended to develop a special tool to remove nuts from the tires with minimum time and effort for women and teens.

### 2. CONSTRUCTION

Nut lightener consists of gears of different sizes, the handle which will be rotated by the operator is connected to the smaller gear which is mounted on the bearings. The wheel nuts are connected to gear drives through extension rods. Slots are provided to make adjustments for opening of tires which are having different centre distances. Linear motion has been provided by keeping a support plate above the gears. The supporting and base plates are connected by bolts and nuts. The modelling of the assembly has been done in SOLID EDGE. The parametric modelling of the gear drives were also carried out. Fig 1 shows Multi-nut lightener and lug tightening pattern.



FIGURE 1: Multi-nut lightener and lug tightening pattern

### 3. WORKING PRINCIPLE

Gears are arranged in such a way that, by applying approximately 200N force with both hands on to the handle will rotate the gears, finally the required torque is applied on to the spanner to open two wheel nuts at a time. The idea is to develop a complete mechanism in one assembly which can be used in automobile workshops, house holds etc. The machine operates when a force is applied by both hands, due to which central gear rotates in the direction as the handle and by the engagement of driven gears rotate in opposite direction. Bearings are attached to support the drives and proper transmission. The force is transmitted to the sockets at the end of the connecting rods and thus the nuts are removed. The pinion meshes with four auxiliary gears which are in turn connected to a gear whose axle containing the socket spanners at its end. The other end is connected to bevel gear. The main shaft and the follower can be placed at any desired position by using a lock nut arrangement. The entire design depends on the gears and its transmission, even the small error can cause the failure of complete assembly. The proper design involves in analysing stresses acting, tooth engagement and meshing etc. It is essential to analyse and simulate the gear drives with advanced software's and to find the proper engagement of the tooth. Fig 2 shows the modelling of gear drive assembly.

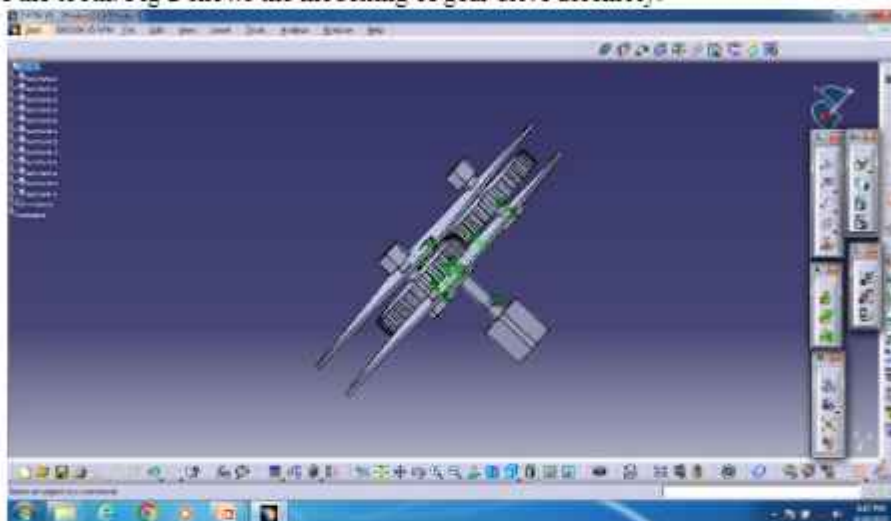

FIGURE 2: Modelling of gear drive assembly

### 4. COMPONENT DETAILS

#### 4.1 Spur Gear

Spur gears are the simplest straight cut gears. It consists of disk or cylinder with projecting teeth radially. If the gears are viewed at 90 degrees from the shaft length the tooth faces are straight and aligned parallel to axis of rotation. Fig 3 shows the spur gear drive



FIGURE 3: Spur gear drive

#### 4.2 Box spanner socket

Socket spanner is a type of spanner that is used as a closed socket format, rather than a typical open type spanner or wrench to turn a fastener, typically in the form of a nut or bolt. The head of the socket wrench resembles the nut or bolt head cover and the sense of the handle not fixed. Fig 4 shows the box spanner socket set.



FIGURE 4: Box spanner socket set

#### 4.3 Bearings

**Ball bearings** are used to reduce the rotational friction and support radial and axial loads. This is achieved by using at least two races to contain the balls and transmit the loads through the balls. As one of the races rotates it causes the balls to rotate as well. Due to the ball rolling they have much lower co-efficient of friction than sliding contact bearing. Fig 5 shows the typical ball bearing.

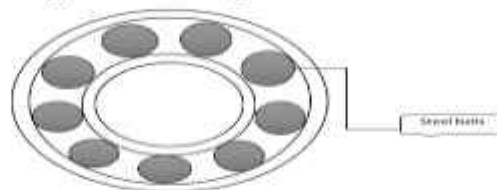

FIGURE 5: A typical ball Bearing

#### 4.4 Power transmitting shaft

Power transmitting shaft is a machine element which is used to transmit power from one place to another. For proper transmission of the power various elements like pulleys, gears, crank etc are mounted on it. Keys and splines are used as mounting elements. The material used for the shaft should have high wear resistant, good heat treatment properties and should have sufficient hardness. Fig 6 shows a typical power transmitting shaft.



FIGURE 6: Power transmitting shaft

#### 4.5 DC Motor

Motors are the electro mechanical devices that convert electrical energy into mechanical energy in the form of torque and rotation. Either alternating current or direct current can be used as an input to the motor. The result is the mechanical motion either translation or rotation. It has mainly two parts namely stator and rotor. Stator is the stationary electrical component and rotor rotates with the main shaft. Fig 7 shows the typical DC motor.



FIGURE 7: shows DC motor



## 5. METHODOLOGY

An extensive survey has been carried out, initially the Modelling of the form tool using CATIA software. Even the parametric modelling of the gears were done based on the results obtained from the design calculations. Finally fabrication of the model has to be performed in accordance with the results obtained.

## 6. CONCLUSION

The design and fabrication of form tool for removing and tightening of the bolts for the tires has been carried out. The gears were designed as per the standards, the validation of the results has to be carried out in been carried out by using finite element software. The results were found to be satisfactory.

## REFERENCES

- [1] Mohd, Azman., 2003 "Design And Fabrication Of Vehicle All Wheel Nuts Remover," International Journal Of Computer Sci. & Electronic Engg. (IJCSEE), Vol.1, Issue 3, ISSN: 2320-401x, pp. 381-384
- [2] Mukhtar, M., 2014 "Design Improvement And Computer Assisted Fabrication On The Impact Wrench For Car Wheel Nuts Puller In Automotive Industry," Australian Journal Of Basic And Applied Sciences, 8(4) Spl., ISSN:1991-8178, pp. 548-553.
- [3] Abd Aziz, A. R., 2008 "Improvement and Optimization of Tyre Nut Remover With 114 PCD," Uni. Malaysia Pahang, Thesis Degree.
- [4] Bhandari, V. B., "Design Of Machine Elements," Tata Mcgraw Hill Publishing House Ltd., Second Edition.
- [5] Dr. Pandya, N. C., and Dr. Shah, C. S., 2009 "Machine Design," Charotar Publishing House Pvt. Ltd., Edition 7<sup>th</sup>.
- [6] [www.macsteel.co.za](http://www.macsteel.co.za)
- [7] Pravin, Kumar, Harsh, Raghuvanshi, 2013 "Design And Analysis Of Spur Gears In Different Geometric Conditions," International Journal Of Engineering And Advanced Technology (IJEAT) ISSN:2249-8958, 3(2), pp. 8-13.
- [8] Malleev, Hartman, Edited By Grover, O. P., "Machine Design," CBS Publishers Pvt. Ltd. Edition 5th.

## LOW COST MECHANICAL FLOOR CLEANING MACHINE- A REVIEW

Darshan Gowda K M

Student

Department of Mechanical Engineering  
K.S. School of Engineering and Management  
Bangalore -560109

### ABSTRACT

*Cleaning is the important factor of daily routine process. Effective cleaning and sanitizing our surrounding helps to improve the mental health of human beings as well as animals around us. At home effective way of floor cleaning can be done by using brooms or mops or even automatic floor cleaning machine which are available in markets. But in areas like hospitals, Schools, Cinema theaters, or any public places manual cleaning is not effective as it may cause health issues and also it will be difficult job for the worker. Purchasing cost and maintenance cost of the automatic floor cleaning machines that are available in the market are very high. Most of these floor cleaning systems are combined with sensors and robotic drives with programmable controllers and few other are operated by remote control. Since these machines uses electric Motors /robots/sensors/ electric circuits, the machine is more delicate, and hence cannot be used to clean rough areas. In order to overcome these problems, there is a need of low-cost eco-friendly floor cleaning machine. Therefore, the main aim of this project is to fabricate eco-friendly floor cleaner with simple mechanical mechanisms, which can be operated easily and with less maintenance cost.*

**Keywords:** Floor cleaning methods, man power reduction, dry and wet cleaner, mopping.

### 1. INTRODUCTION

#### 1.1 NEED FOR FLOOR CLEANING METHOD

Cleaning machine is very much useful in cleaning floors and outside ground in hospitals, houses, auditorium, shops, bus stands and public place etc. In modern days interior as well as outside cleaning are becoming an important role in our life. Cleaning of waste is a very important one for our health and reduces the man power requirement. Many of floor cleaning machines are available but we developed machine is very simple in construction and easy to operate. Anybody can operate this machine easily. Hence it is very useful in hospitals, any large area space. The time taken for cleaning is very less and the cost is also very less. Maintenance cost is less. Much type of machines is widely used for this purpose. In our project we have made the machine to operate in a fully mechanical way with a little amount of electrical components. The Floor cleaner is of very simple construction and is very easy to operate; anyone can operate it without any prior training of any sorts with safety. It is very important one in any hospitals, hotels, bus stands etc.

Effective cleaning and sanitizing helps and protect the health of the human beings directly and indirectly. Also, cleaning and sanitizing prevents the pest infestations by reducing residues that can attract and support bees, pests etc. It also improves the shelf life of the floor, walls etc due to regular cleaning and maintenance. In recent years, most of the people prefer to use trains or buses for commuting and hence these places are littered with biscuits covers, cold drink bottles etc. Hence, it is necessary to clean the bus stands and railways stations at regular interval. There is no one single cleaning method that is suitable for all locations and occasions and effective cleaning depends upon type of cleaning device, cleaning technique and also the equipment should be user friendly. Cleaning work can be physically demanding and a need has been identified to developed methods for systematic ergonomics evaluation of new products. Anybody can operate this machine easily. It consist of moisture cotton brush, the brush cleans the floor and dried with aid of small blower. Hence it is very useful in hospitals, houses, etc. The time taken for cleaning is very less and the cost is also very less. Maintenance cost is less. Much type of machines is widely used for this purpose. But they are working under different principles and the cost is also very high.

#### 1.2 DIFFERENT METHODS OF FLOOR CLEANING MACHINES

- Traditional damp mopping is the first method of floor.
- As technology develops the robots were able to clean the floor.

- Using sensors the remote control floor cleaner has been introduced.
- By mechanical means some of the floor cleaners are introduced in today's market.

## 2. EXISTING SYSTEM

Many researchers have designed and fabricated floor cleaning machine which are operated using various techniques. These works are been discussed in the following paragraph

Samarth G Gaikwad [1] designed and developed a Multi-functional floor scrubber and cleaner as shown in fig 2.1. The main components of the machine are tanks for cleaning water, Supporting Structure of the machine, Vacuum and squeegee arrangement. Brush and Motor Assembly, Speed Reduction Pulleys. By using a pump and timer-controlled mechanism the solution can be sprayed at regular intervals resulting in its efficient usage. Also, ultrasonic sensors with line and follower arrangement will make the machine autonomous. There is also a scope to suck the debris and small chips on the floor by utilising the vacuum pump or by creating a separate magnetic chip collection mechanism which can be attached at the frontend of the machine. The dirty water from the floor is discharged into the tank through high quality vacuum hose attached to the squeegee that we can see in the same fig 1. The hose is connected to the squeegee by special rubber connectors which ensure that there is no any leakage through joints. Tanks were fitted in frame and spot welded to make the assembly permanent. Then the motor with speed reduction pulley and brush were assembled. Then this setup was fitted to the mounting bracket with the help of nut and bolts. A swinging arrangement is provided between the motor and bracket to ensure effective cleaning even on uneven floors.



FIGURE 1. Multi-functional floor scrubber and cleaner

M. Ranjith Kumar [2] designed a manually operated floor cleaning machine in which it can perform both for dry mopping and wet mopping which we can observe in fig 1. In which it consists of Body (for pedal operated), Frame (dry cleaner), Brushes (dry cleaning), Dust chamber, supporting wheels, Mop (wet cleaning), Distributer tube (disinfectant liquid) and Water tank. For manual operation, pedal operated body is selected as the rider machine, to which dry cleaner (sweeper) attachment is made to the front wheel of the body. A frame is constructed for dry cleaning purpose, one side which brushes are winded and the shaft rotates by driven mechanism thereby pushing the dust into the dust chamber attached to the frame. For wet cleaning, wet mops are attached at the rear end of the body, which operates by sliding mechanism on the floor when the body moves, disinfectant liquid is spread just before the mops from a plastic tank during wet cleaning operation. This floor cleaning machine is specifically designed to clean the floors which are plane and smooth, such as tiles, mosaic and cemented smooth surfaces.

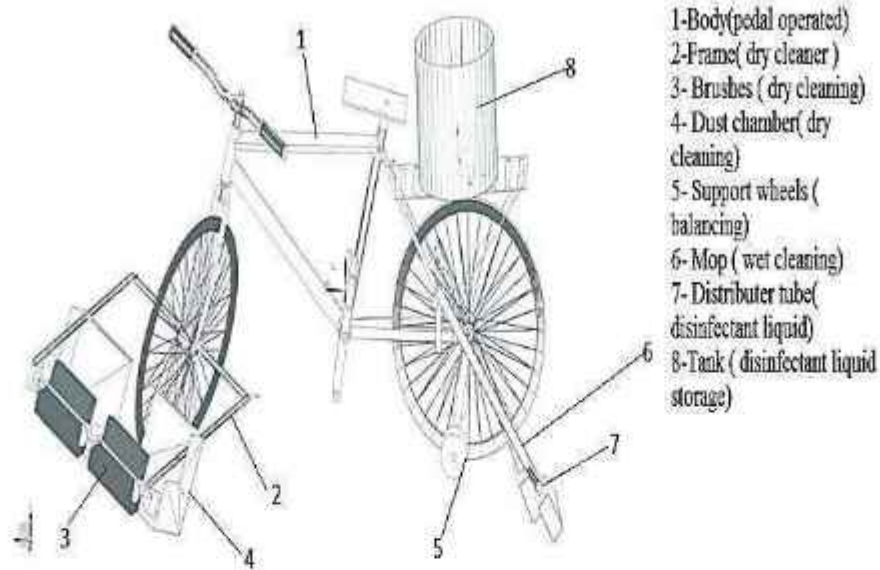

FIGURE 2. Manually operated floor cleaning machine

S. Monika [3] designed and implemented Smart Floor Cleaning Robot using Android App shown in fig 2. A robot vacuum cleaner is an autonomous robotic vacuum cleaner which includes self-drive mode and cleans the floor autonomously without human control. This robot vacuum cleaner consists of spinning brushes, mopping, UV sterilization and security cameras for cleaning purpose. This vacuum cleaner had some drawbacks like colliding with obstacles and stopped at a shorter distance from walls and other objects. It was not able to reach to all corners and edges of the room and left those areas unclean. An automatic floor cleaner robot has brushes attached to its sides to collect the dust. This robot uses ultrasonic sensors to avoid obstacles and change its direction and it has a suction unit that sucks in the dust while moving around the room freely. But the drawback of this robot is that it cannot clean the wet floor. The sweeping brush placed under it sweeps the dust and waste from corners and edges. It has a powerful motor suction unit which sucks in the dirt into the filtered dust bin.



FIGURE 3. Floor cleaning robot using android app

Chawan Swaroop[4] designed a Semi-automatic floor cleaner with obstacle avoidance for indoor applications is shown fig 3. The robot floor cleaner is equipped with some standard parts. These are the batteries, and electrical motors, and Arduino circuit. They selected motor of 60rpm. For the better control over the movement of the robot 2-wheel drive mechanism is selected. Aurdino circuit consists of Arduino Mega 2560, Ultrasonic Sensor, Servo Motor, L298N Motor Driver, DC Motor. This cleaner is Considered for indoor application, by select the motor which creates that much vacuum and from this analysis and used found a motor with centrifugal compressor from portable car vacuum cleaner and also provide a dustbin inside. For clamping of vacuum cleaner they fixed the

broad compartment at backside by using U clamp. Chassis which assembles all parts and carries all stresses without distortion. Using rivets and nut bolts we clamped all components on chassis. It contains everything needed to support the microcontroller simply connect it to a computer with a USB cable or power it with a AC-to-DC adapter or battery. The future scope of the designed product is, it can be enhanced with addition of total automatic working using Bluetooth/Wi-Fi module, Battery monitoring, self-charging, and to set alarm on/off time manually are the future scope of this project.



**FIGURE 4. Semi-automatic floor cleaner**

Senthil Kumar [5] designed a Remote Controlled Autonomous Floor Cleaning Robot as shown in fig 4. This Floor Cleaner is an integrated floor cleaning device. It has three major components of Machine, water pump, pipes, Mop Assembly and Pad Driver. Machine consists of 1 pair of wheels, squeeze assembly, solution tank, rubber skirt and gallon recovery tank. And the machine outer layer is made up of Durable plastic housing is corrosion and impact resistance. In this machine there have been used two types of mops which is first one is for Dry cleaning and another one for wet cleaning. Dry/dust kind of mops are used here to absorb dry and loose particles like dust, earth etc. from the surface of the floor. It consists either a yarn or similar kind of fabric and it is considered as a initial step of cleaning a floor. A wet mop is used as a secondary step in cleaning surface and is swept all over the surface to dissolve and absorb liquid form of waste. The pump transfers the water from the water storage tank and spills it in front of the mops on the floor. And they use of rubber pipes and connect it to the inlet of pump to take water from the water tank using the pump to drop it in front of the mops. The pump can be operated via smart phone.

In this design they have used sensors. In this case sensors are basically used for observation of the stairs. Sharp sensors are used so that it can detect a drop in height and eventually helps the robot detect any change in the height drop of the surface such as stairs or high platforms. When sensor detects stairs, state on the output will be high. Once the drop in height is detected, the robot immediately goes back to a safer area so that it can operate like it does in normal conditions.



**FIGURE 6. Remote controlled floor cleaning robot**

Pranav [6] designed automatic floor cleaner which helps to cleaning the floor automatically with the help of motor source as shown in fig 6. The main components required for constructing the floor cleaning machine are dc motor, water tank, water solenoid valve, ac motor, scrubber, belt & pulley, chain drive, battery, electronic control board. In this device, a motor is used as a power drive. It consists of scrubber, water tank, water solenoid valve, belt, pulley arrangement and wheels. Foam water is stored in the water tank and is sprayed to the floor by actuating the water solenoid valve, and a scrubber will clean the floor by means of rotation of motor, the scrubber will rotate through motor and chain drive.

#### Gap in the Literature:

- The floor cleaner available in market is costing and very sensitive to large surface.
- Flooring must be flat surface without bumps or bubbles. □ Vacuum cleaner robots cannot cope with obstacles well.
- Heavy to lift the vacuum cleaners as they are bulky
- Running electricity bill depending on the vacuum cleaner model.
- No reusable dustbin bags.

To overcome above problems, fabricating a simple floor cleaning machine which can be operated mechanically is needed.

### 3. METHODOLOGY

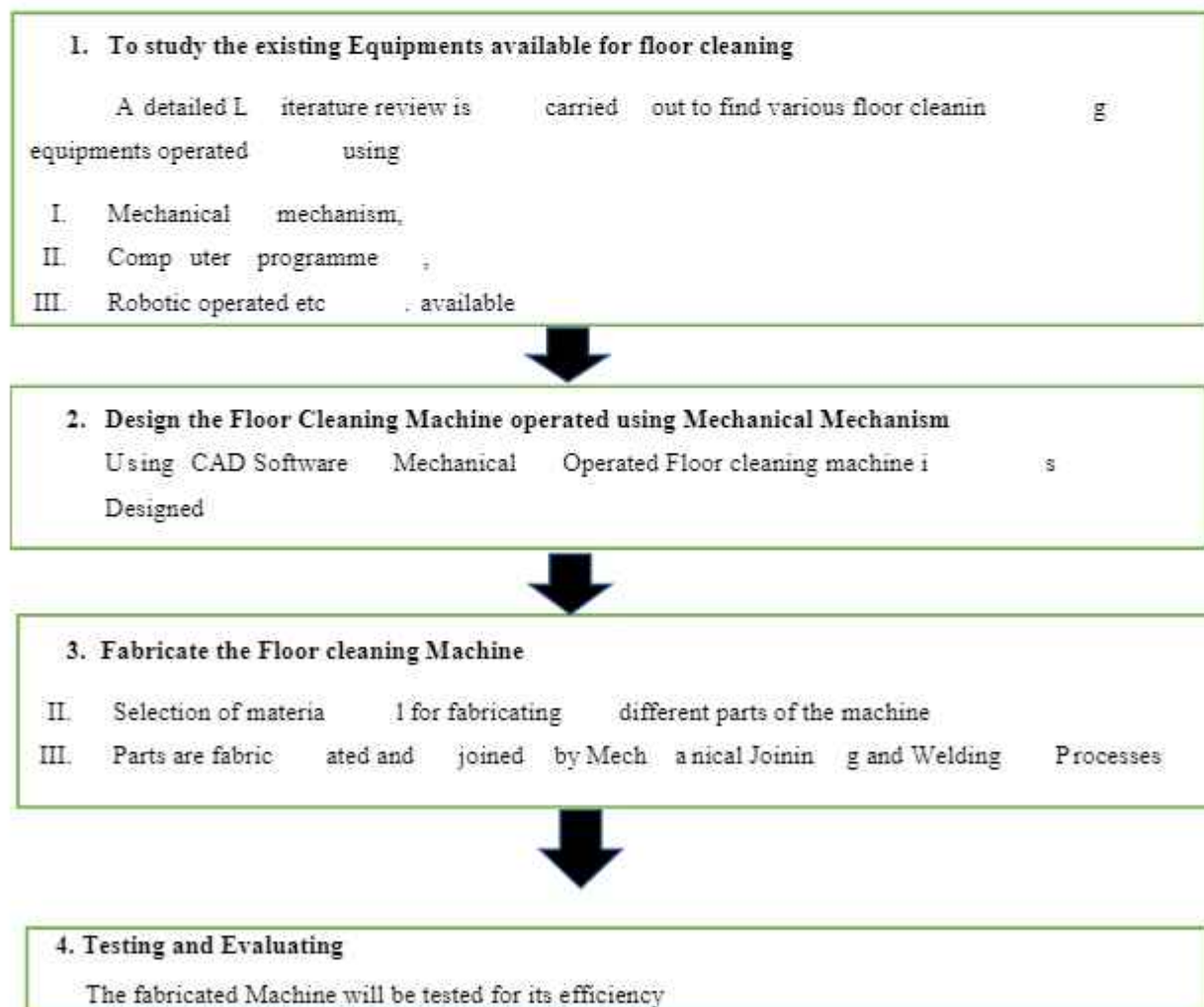

#### 4. EXPERIMENTAL DETAILS

Figure 8 a & 8 b below shows the manual sketch for the proposed model and fig 8c shows the final Design of the proposed model prepared using CAD software

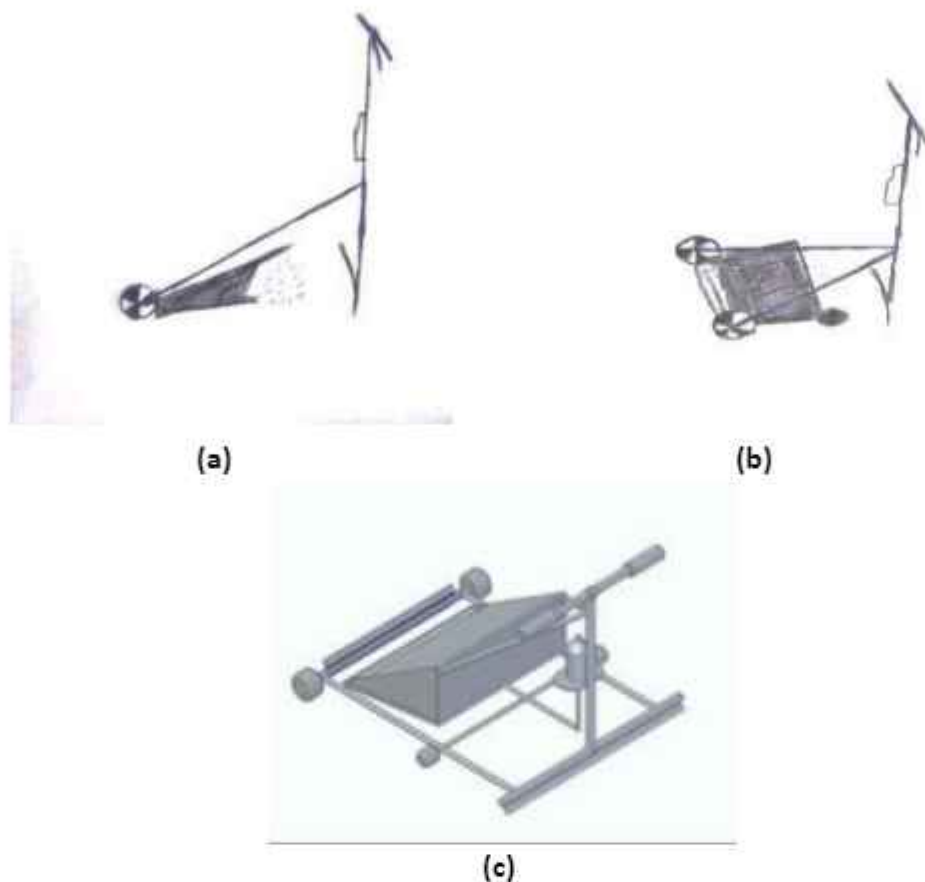

**FIGURE 8. Proposed Designs**

Cleaning machine is very much useful in cleaning floors and outside ground in hospitals, houses, auditorium, shops, bus stands and public place etc. The machine which we designed is run by a human effort or a man power. The roller brush is fixed with pair of wheels which are present in the front and it is connected with the help of shaft. And for Wet cleaning process Mop is connected at the rear end. And liquid solution can be stored in the bottle which is present near the handle. The handle can be adjusted for a required height. And mechanism of the designed floor cleaning machine is totally mechanical. When the force is applied manually, the wheels are moved and the roller acts as a cleaning brush. The forward movement of the wheels collect the trash into the bin. This bin is further removed to dump the waste to the desired place.

At the handle we can observe a mop. A plastic bottle is fixed to the same handle of the mop, which consists of either a plain water or floor disinfectant mixed water used to clean the floor. It's manually operated and the cost is also low.

#### Expected Outcome

The Proposed Model is cost efficient, as it can be made of simple parts, like mop, water bottle, sheet metal and rod

- Simultaneously both wet and dry-cleaning process is possible.
- It environment friendly product as it can be operated manually without any external power source

#### 5. CONCLUSIONS

This project proposes floor cleaning Machine, which can be operated in easier manner and more efficiently when compared to manual cleaning. The human effort required for cleaning large areas can be reduced by implementing

this floor cleaner. This project is designed and fabricated with an idea of simplifying the process of floor cleaning. Its model is designed in such a way that it provides flexibility in operation and effortless cleaning at a reasonable budget. This project titled "LOW COST MECHANICAL FLOOR CLEANING MACHINE" is designed with the hope that it will be very much useful & economical and helpful for industries, hospitals, workshops and households.

## REFERENCES

- [1] Samarth G. Gaikwad, Shashank S. Kulkarni, Virendra P. Patil, Ashutosh S. Nagargoje, " Design and Development of Multi-Functional Floor Scrubber and Cleaner", International Journal of Scientific & Technology Research Volume 8, ISSUE 12, 2019.Pp 3638-3644
- [2] Ranjit Kumar, Kapilan, "Design and Analysis of Manually Operated Floor Cleaning Machine", International Journal of Engineering Research & Technology (IJERT), Vol. 4 Issue 04, 2015,pp 828-831
- [3] S Monika, K Aruna Manjusha, S V S Prasad, B Naresh, "Design and Implementation of Smart Floor Cleaning Robot using Android App", International Journal of Innovative Technology and Exploring Engineering (IJITEE), Volume-8 Issue-4S2, 2019,pp 250-252
- [4] Chavan Swaroop Chandrakant,Parulekar Sharvarish Shashikant, Gavali Omkar, Raju, Gokhale Shantanu Bhalchandra, Shinde Vaibhav Tanaji, "Semi-Automatic Robotic Floor Cleaner with Obstacle Avoidance for Indoor Applications", International Research Journal of Engineering and Technology (IRJET), Volume: 05 Issue: 02 , 2018, pp ,881-886
- [5] R.Senthil Kumar, Vaisakh KP, Sayanth A Kumar, Gaurav Dasgupta, " Remote Controlled Autonomous Floor Cleaning Robot", International Journal of Recent Technology and Engineering (IJRTE), Volume-8, Issue-2S11, 2019, pp 2497-2503
- [6] Pranav P, Midhun Shankar M, Tomin Jose , Vibin Chandi Varghese, "Automatic Floor Cleaner", International Research Journal of Engineering and Technology (IRJET) , Volume: 05 Issue: 04 ,2018, pp 3091-3094
- [7] Rajaranjan Senapati, "Automation and Controlling of Automatic Floor Cleaner", National Institute of technology, Rourkela-2015
- [8] Madan Jagtap , Akash, Uttam, Faisal, Suhas, "Multitasking floor cleaning Machine", International Journal of Scientific & Engineering Research Volume 10, Issue 5, 2019,pp 133135
- [9] Vikrant Bhute,Piyush Ladse,Aniket Ingle,Nitesh Rane, "Solar Operated Multifunctional Floor Cleaning Machine", International Journal of Advances in Engineering and Management (IJAEM),Volume 2, Issue 10, pp 689-692
- [10] Ajith Shetty, Sachin S, Shivaprasadm, Solar Powered Floor Cleaner Cum Grass Cutter (An Ecofriendly Machine), Electrical And Electronics Engineering , Srinivas Institute of Technology, Valchi, Mangalore, Project Reference Number: 38S0600
- [11] Saravanan N, Sanjay S, Sreenithyanandan R S, Vimal Raj T, "Fabrication Of Floor Scrubber Machine", International Journal Of Scientific & Technology Research Volume 9, Issue 02, 2020,pp 2251-2253.



## DESIGN AND FABRICATION OF LOW COST MECHANICAL VENTILATOR

Anirudh R<sup>1</sup>, Harsha P<sup>1</sup>, Mallikarjun Holde<sup>1</sup>, Mohan R Krishna<sup>1</sup>, Nirmala L<sup>2</sup>

<sup>1</sup> Students, <sup>2</sup> Associate Professor  
Department of Mechanical Engineering  
K.S. Institute of Technology Bangalore -560109

### ABSTRACT

This paper shows the construction of low cost mechanical ventilator. which is a device used for patients with acute breathing problems. The main motivation for this project is to bridge the demand for ventilator during covid19. and to reduce the cost of ventilation. This is very effective and matches with the clinical ventilators. Simple mechanism (slider and crank) is selected wisely to get effective ventilation at min cost. Experiments carried out in the laboratory that had emulated healthy and unhealthy patients illustrate the potential benefits of the derived mechanical ventilator.

**Keywords:** Mechanical ventilator, low-cost ventilator, Covid-19, Slider crank.

### 1. INTRODUCTION

Ventilators are the life saving machines used as very crucial equipment in icu's it is used for the patients with acute respiratory failure[1]. The concept of ventilation is not new it was developed by Greek physician and scientist gallen in second century AD [2]. At that time it was termed as "iron lungs " [4]. Later on during mid of 16th century scientist by name Andreas Vesalius published his work by the title.

"Dehumani corporis fabrica" which is the base for modern positive pressure ventilator [5]. In 1864 Alferd Jones designed first ventilator which at the time was used to treat paralysis, bronchitis, asthma [6]. later on lot of development took place in this field as a result we have more sophisticated more accurate ventilators in hospitals[7]. But situation changed after February 2020 the need of ventilator increased to peak due to the pandemic Covid-19. India having a population of 140 crore has only 48000 clinical ventilators[8], number of cases crossed 7 lacks per day this created huge short age of clinical ventilator, it was imported from different countries in large amount[9]. At that time the concept of low cost portable ventilator was introduced this can be used to a patient[12] with mild to moderate respiratory failures it is non invasive[13], reliable device that can be used as alternative to bulky expensive hospital ventilators this ventilators can be brought by small clinics or an individual and it does not require any specialized person to operate it [14].

### 2. MATERIALS

#### 2.1. Ply Wood:

Plywood is a material manufactured from thin layers or "plies" of wood veneer that are glued together with adjacent layers. It is an engineered wood from the family of manufactured boards which include medium-density fiberboard (MDF), oriented strand board (OSB) and particle board (chipboard). The board is used of dimension 550\*305mm as shown in [fig1](#)



FIGURE 1. Plywood

## 2.2 PVC PIPE:

PVC pipes have clear environmental advantages over traditional materials. As PVC is a low carbon plastic, PVC pipes require less energy and fewer resources to manufacture. Moreover the ultra-smooth surface of PVC pipes reduces pumping costs and energy use. The pipes are of 290mm length, 32mm diameter and 405mm length, 26mm diameter, shown in [fig2](#)



FIGURE 2. PVC Pipes

## 2.3 FLANGE:

A flange is a method of connecting pipes, valves, pumps and other equipment to form a piping system. Pipe flanges are manufactured in all the different materials like stainless steel, cast iron, aluminum, brass, bronze, plastic etc. The flange we used is of 8mm diameter. As Shown in [fig3](#)



FIGURE 3. Flange

## 2.4 AMBUBAG:

A bag valve mask (BVM), sometimes referred to as an Ambu bag as shown in [fig 4](#), is a handheld tool that is used to deliver positive pressure ventilation to any subject with insufficient or ineffective breaths. It consists of a self-inflating bag, one-way valve, mask, and an oxygen reservoir. A Ambu bag of 1600ml capacity is used.



FIGURE4.. Ambubag

## 2.5 DC MOTOR:

Motors are the electro mechanical devices that convert electrical energy in to mechanical energy in the form of torque and rotation. Either alternating current or direct current can be used as an input to the motor. The result is the mechanical motion either translation or rotation. It has mainly two parts namely stator and rotor. Stator is the stationary electrical

component and rotor rotates with the main shaft. We have used a motor of 12V,3A and 20kg-cm torque.

## 2.6 SPEED CONTROLLER:

Motor speed controllers are electronic devices that control motor speed. They take a signal for the needed speed and drive a motor to that speed. The controller is of 12v, 3A operating power . As Shown in fig 6



FIGURE 6. .Speed controlling unit

## 2.7. POWER SUPPLY:

A power supply is an electronic circuit that converts the voltage of an alternating current (AC) into a direct current (DC) voltage. It is basically consisting of the following elements: transformer, rectifier and filter. It converts Ac to DC and supplies current at 12v.

## 3. METHODS

The layout as shown in fig 8 was constructed in order to reduce the area and arrange the components compactly and efficiently for working purpose.

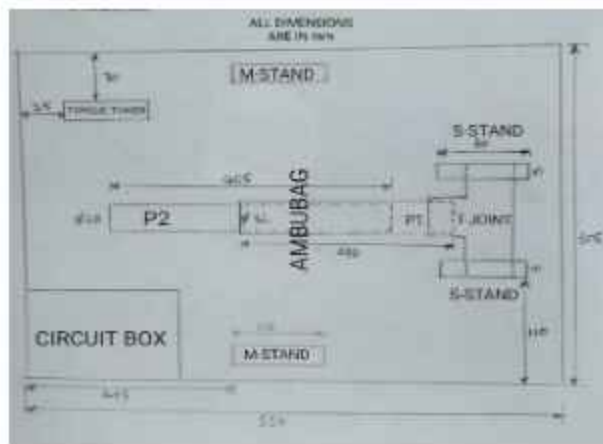

FIGURE 8. 2D Layout

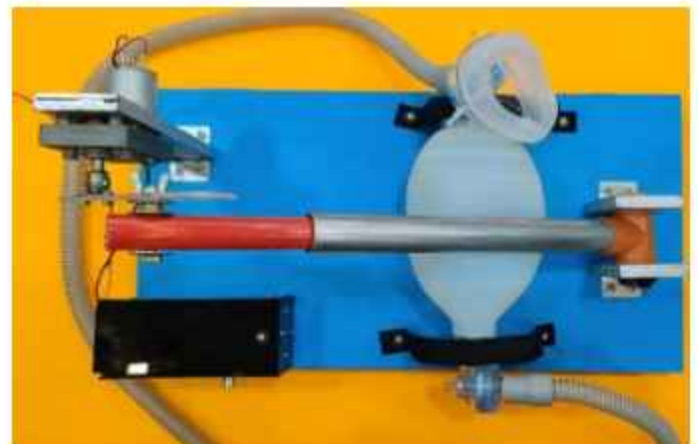

FIGURE 9.. Fabricated Model

Two S-stands are mounted on the ply wood base to support the slider crank mechanism using T joint, Ambu bag is placed over the M-stand above which PVC pipes are incline arranged. On the left top of layout torque tower is placed where DC motor rotates the acrylic arm in clockwise direction, whose speed can be altered from the circuit box, where circuit connections are done. The final outlook is as shown in fig(9) .

## 4. WORKING PRINCIPLE

Fabrication was made in such a way that during the first half cycle rotation of the acrylic arm the PVC link compresses the ambu bag that creates the pressure on the outer valve due to which the oxygen is pushed towards the patient. Similarly during the second half cycle of acrylic arm the PVC link retraces its path, due to the vacuum created in the bag the pressure is built on the inlet valve as the result oxygen occupies the void space in the ambu bag. This is how the slider crank mechanism of the PVC link helps in pumping the oxygen.

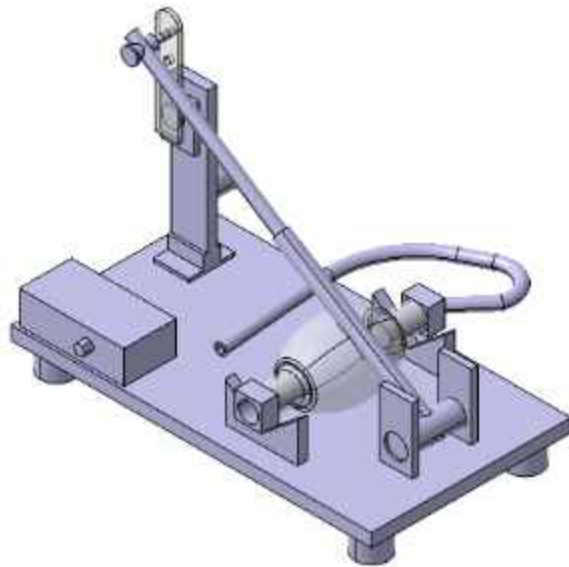

FIGURE 10. 3D Catia Model



FIGURE 11. Fabricated Model

## 5. RESULTS AND DISCUSSION

Fabricated device was tested at its full operating speed which is about 13-15 rpm which is the average rate of breathing [1], and at different settings of compression of the ambubag and the results found are as shown in the table.

TABLE 1. Experimental results

| SI No | COMPRESSION | PRESSURE<br>(mm of Hg) | PRESSURE<br>(Kpa) |
|-------|-------------|------------------------|-------------------|
| 1     | 1/4         | 7                      | 0.93              |
| 2     | 1/2         | 13                     | 1.73              |
| 3     | 3/4         | 18                     | 2.4               |

The average pressure which is needed for an adult is 5-25mm of Hg[8]. After the conduction of the experiment the pressure developed during the 1/4<sup>th</sup> compression was 7mm of Hg (0.93Kpa), at 1/2 compression the pressure developed was 13mm of Hg (1.73Kpa), at 3/4<sup>th</sup> compression the pressure developed is 18mm of Hg (2.1Kpa). The developed pressure falls well within the range of pressure that is required for an adult.

## 6. CONCLUSION

The developed project works on the principle of slider crank mechanism to develop positive pressure for respiration, and the pressure developed falls under the required range of pressure required for an adult human, the device built is cost effective and can be used on patients with low to moderate respiratory problems.

## 7. REFERENCES

- [1] D. J. Dries and J. J. Marini, "Mechanical Ventilation," *Crit. Care Nephrol.* Third Ed.vol.196, no. April, pp. 10-21.e2, 2019, doi:10.1016/B978-0-323-44942-7.00003-0.
- [2] G. C. Khilnani and V. Hadda, "Basic mechanical ventilation," *ICU Protocol. A Step wise Approach Vol I*, pp. 45–53, 2019, doi:10.1007/978-981-15-0898-1\_5.
- [3] P. Rodriguez, M. Dojat, and L. Brochard, "Mechanical ventilation: Changing concepts,"  
a. *Indian J. Crit. Care Med.*, vol. 9, no. 4, pp. 235–243, 2005, doi:10.4103/09725229.19765.
- [4] L. Acho, A.N. Vargas, and G. Pujol-Vázquez, "Low-Cost, open-source mechanical  
a. ventilator with pulmonary monitoring for COVID-19 patients," *Actuators*, vol. 9,  
b. pp. 1–14, 2020, doi:10.3390/act9030084
- [5] J. Zuckerberg, M. Shaik, K. Widmeier, T. Kilbaugh, and T. D. Nelin, "A lung for all: Novel mechanical ventilator for emergency and low-resource settings," *Life Sci.*, vol. 257, no. June, p. 118113, 2020, doi:10.1016/j.lfs.2020.118113.
- [6] A. Mohsen Al Hussein, H. Ju Lee, J. Negrete, S. Powelson, A. Tepper Servi, and A. H. Slocum, "Design and prototyping of a low-cost portable mechanical ventilator," *J. Med. Devices, Trans. ASME*, vol. 4, no. 2, pp. 1–1, 2010, doi:10.1115/1.3442790.
- [7] V. Kumar, R. Kumar, M. Kumar, G. S. Wander, V. Gupta, and A. Sahani, "Recent advances in low-cost portable automated resuscitator systems to fight COVID-19," *Health Technol. (Berl.)*, vol. 12, no. 1, pp. 181–191, 2022, doi:10.1007/s12553-021-00629-4
- [8] A. Mohsen Al Hussein, H. Ju Lee, J. Negrete, S. Powelson, A. Tepper Servi, and A. H. Slocum, "Design and prototyping of a low-cost portable mechanical ventilator," *J. Med. Devices, Trans. ASME*, vol. 4, no. 2, pp. 1–1, 2010, doi:10.1115/1.3442790.
- [9] L. E. Schwab, "Basics of mechanical ventilation," *Trauma*, vol. 45, no. 4, pp. 61–70, 2003, doi: 10.5005/jp/books/13067\_13.
- [10] et al. Vivas Fernández, Francisco José, "ResUHUrge : A Low Cost and Fully Functional," *Sensors*, vol. 20, no. 23, 2020, [Online]. Available: <https://www.mdpi.com/1424-8220/20/23/6774/htm>
- [11] S. Fludger and A. Klein, "Portable ventilators," *Contin. Educ. Anaesthesia, Crit. Care Pain*, vol. 8, no. 6, pp. 199–203, 2008, doi: 10.1093/bjaceaccp/mkn039.
- [12] W. H. Organization, "Technical specifications for invasive and non-invasive ventilators for COVID-19," *Interim Guid.*, no. April, pp. 1–10, 2020.
- [13] T. Laerdal, "Portable ventilators," *Br. J. Anaesth.*, vol. 54, no. 8, p. 900, 1982, doi: 10.1093/bja/54.8.900-a.
- [14] J. Brewer, "Senior Project Final Report Portable Ventilator Table of Contents :," 2021.
- [15] C. Care, N. Knowledge, O. F. Evidence, and V. A. Pneumonia, "CRITICAL CARE NURSES KNOWLEDGE OF EVIDENCE BASED GUIDELINES FOR PREVENTING -," no. October, 2007.
- [17] D. Carina, "Evaluation Portable / Transport Ventilators," no. March, pp. 74–93, 2010.
- [18] L. Acho, A. N. Vargas, and G. Pujol-Vázquez, "Low-Cost, open-source mechanical ventilator with pulmonary monitoring for COVID-19 patients," *Actuators*, vol. 9, no. 3, pp. 1–14, 2020, doi: 10.3390/act9030084.
- [19] J. Zuckerberg, M. Shaik, K. Widmeier, T. Kilbaugh, and T. D. Nelin, "A lung for all: Novel mechanical ventilator for emergency and low-resource settings," *Life Sci.*, vol. 257, no. June, p. 118113, 2020, doi: 10.1016/j.lfs.2020.118113.
- [20] A. Mohsen Al Hussein, H. Ju Lee, J. Negrete, S. Powelson, A. Tepper Servi, and A. H. Slocum, "Design and prototyping of a low-cost portable mechanical ventilator," *J. Med. Devices, Trans. ASME*, vol. 4, no. 2, pp. 1–1, 2010, doi: 10.1115/1.3442790.
- [21] S. H. Szal, "Design and Development of a Low- Cost Automatic Ventilator," no. April, 2020.
- [22] M. S. G. Tsuzuki *et al.*, "Mechanical Ventilator VENT19," *Polytechnica*, vol. 4, no. 1, pp. 33–46, 2021, doi: 10.1007/s41050-021-00031-z.
- [23] A. Mohsen Al Hussein, "MIT E-VENT | Emergency ventilator design toolbox," *Proc. 2010 Des. Med. Devices Conf.*, pp. 1–9, 2010, [Online]. Available: <https://e-vent.mit.edu/>

- [24] V. Kumar, R. Kumar, M. Kumar, G. S. Wander, V. Gupta, and A. Sahani, "Recent advances in low-cost, portable automated resuscitator systems to fight COVID-19," *Health Technol. (Berl)*, vol. 12, no. 1, pp. 181–191, 2022, doi: 10.1007/s12553-021-00629-4.
- [25] S. M. Ali, M. S. Mahmood, and N. S. Mahmood, "Design of a Low-Cost Ventilator to Support Breathing for Patients with Respiratory Failure Arising from COVID-19," *IOP Conf. Ser. Mater. Sci. Eng.*, vol. 1067, no. 1, p. 012143, 2021, doi: 10.1088/1757-899x/1067/1/012143.
- [26] R. M. Kacmarek, "The mechanical ventilator: Past, present, and future," *Respir. Care*, vol. 56, no. 8, pp. 1170–1180, 2011, doi: 10.4187/respcare.01420.

## DESIGN AND FABRICATION OF SEMI-AUTOMATED MACHINE VICE

Dhanush B M<sup>1</sup>, Chethan Kumar R<sup>1</sup>, Dhanaraj H D<sup>1</sup>, Anil Kumar A<sup>2</sup>

<sup>1</sup> Students, <sup>2</sup> Assistant Professor  
Department of Mechanical Engineering  
K.S. Institute of Technology Bangalore -560109

### ABSTRACT

The present paper represents the design and development of semi-automated machine vice. In this the work piece will be held and released automatically for the machining process with the help of pneumatic cylinder. When the workpiece is present between the jaw the IR sensors senses the workpiece and signal is fed to the circuit board, in the circuit board Arduino is present which controls the operating process, the pneumatic cylinder piston will move forward the moving jaw front and hold the workpiece rigidly. It reduces the human power, the jaw will move fast and hold the work piece, the drilling operation is carried out after the operation is carried out the jaw will return back to its position. Also increases the accuracy and the time utilization is reduced.

**Keywords:** Semi-Automated Machine Vice, Pneumatics, Arduino, IR Sensor, Solenoid Valve.

### 1. INTRODUCTION

A machine vice is a work holding device used to hold a work piece while operating it on a drill press or milling machine.

Work holding and releasing is the most essential act to carry out machining. These are commonly used in the machine shop[2]. Its main objectives are to hold the job in proper position, release the job quickly, hold the job rigidly, to prevent vibration of the job while the machining is carried out[6]. There are many types of work holding devices like machine vices swivel vices, universal vice, pipe vice, T-Bolt's 'U' clamps, Goose neck clamp, angle plate, Jigs and fixtures etc. These are all mechanical type work holding devices[1,3]. In the previous inventions the jaw was used to move by manual power where it had many disadvantages like time consuming, more human power to tight the work piece[8]. So, in this project we developed a machine vice which works by the use of air compressor using Arduino and sensor for the drilling operation. Here the loading and unloading is quick. The job can be held more rigidly.

### 2. COMPONENTS

To obtain the fabricated model the below mentioned components are used and they are explained as follows:

#### 2.1 Arduino Uno

Arduino Uno is a popular microcontroller development board based on 8-bit ATmega328P microcontroller. Along with ATmega328P MCU IC, it consists of other components such as crystal oscillator, serial communication, voltage regulator, etc. to support the microcontroller.



FIGURE 1: Arduino [11]

#### 2.2 IR Sensor Module

The IR sensor module consists mainly of the IR Transmitter and Receiver, Op-amp, Variable Resistor (Trimmer pot), output LED along with few resistors.

IR LED emits light, in the range of Infrared frequency. IR light is invisible to us as its wavelength (700nm – 1mm) is much higher than the visible light range. IR LEDs have light emitting angle of approx. 20-60 degree

and range of approx. few centimeters to several feet, it depends upon the type of IR transmitter and the manufacturer. Some transmitters have the range in kilometers.

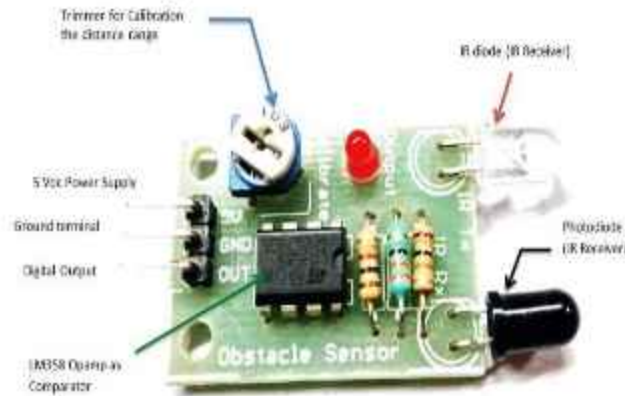

FIGURE 2: IR Sensor [12]

### 2.3 5V Dual-Channel Relay Module

The dual-channel relay module is more or less the same as a single-channel relay module, but with some extra features like optical isolation. The dual-channel relay module can be used to switch mains powered loads from the pins of a microcontroller. Dual-Channel Relay Module Specifications consists of: Supply voltage 3.75V to 6V, Trigger current – 5mA, Relay maximum contact voltage – 250VAC, 30VDC, Relay maximum current – 10A.

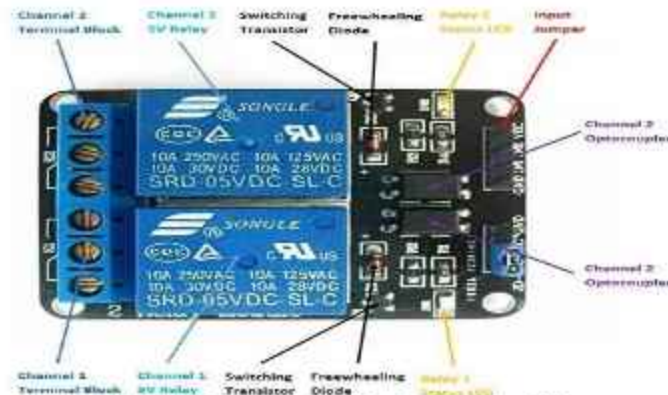

FIGURE 3: 2 Channel Relay Module [13]

### 2.4 Pneumatic Cylinder

Pneumatic cylinders are mechanical devices which use the power of compressed gas to produce a force in a reciprocating linear motion. It consists of pistons and cylinder. The cylinder is a Single acting cylinder one, which means that the air pressure operates forward and spring returns backward. The air from the compressor is passed through the regulator which controls the pressure to required amount by adjusting its knob. The piston is generally made up of Aluminium and is of medium work. The Pneumatic Cylinder is made up of Cast iron graded.



FIGURE 4: Pneumatic Cylinder [14]



### 2.5 Solenoid Valve

The Solenoid Valve is also known as Directional Valve is one of the important parts of a pneumatic system. Commonly known as DCV, this valve is used to control the direction of air flow in the pneumatic system. The directional valve does this by changing the position of its internal movable parts. It is of  $\frac{1}{2}$  inches and has the pressure of 0 to 7kg/cm<sup>2</sup>. It is the type of 5/2 Solenoid valve. It is made up of High-Speed Steel HSS.



FIGURE 5. Solenoid Valve [15]

### 2.6 PU Connectors, Reducer and Hose Collar

In our pneumatic system there are two types of connectors used, one is the hose connector and the other is the reducer. Hose connectors normally comprise an adapter (connector) hose nipple and cap nut. These types of connectors are made up of brass or Aluminium or hardened steel. Reducers are used to provide inter connection between two pipes or hoses of different sizes. These reducers are made up of gunmetal or other materials like hardened steel etc.



FIGURE 6. Connectors, Reducer and Hose Collar [16]

### 2.7 Stand

It generally consists of four legs and is made up of Mild Steel. It acts as supporting frame. The Pneumatic cylinder is clamped to the stand and the whole top body is mounted on it. The dimensions are 480x300x270mm and the thickness is 20mm.



FIGURE 7. Stand

### 2.8 Drill Motor

A drill is a tool used for making holes. This is connected to the DC motor which is mounted on the top of the model. When the Sensor senses the work piece present between the jaw the drill operation starts.



FIGURE 8:: Drill Motor [17]

### 2.9 Battery

The Lead-Acid Battery is used to start the model fabricated for working process. It is a type of rechargeable battery with a specification of 12V, 7.5A.



FIGURE 9. Battery

### 3. DESIGN AND ASSEMBLY

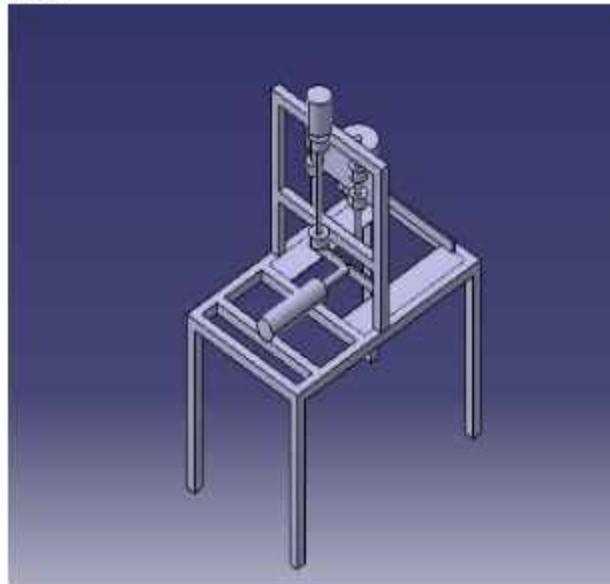

FIGURE 10. Isometric View of Fabricated Machine Vice

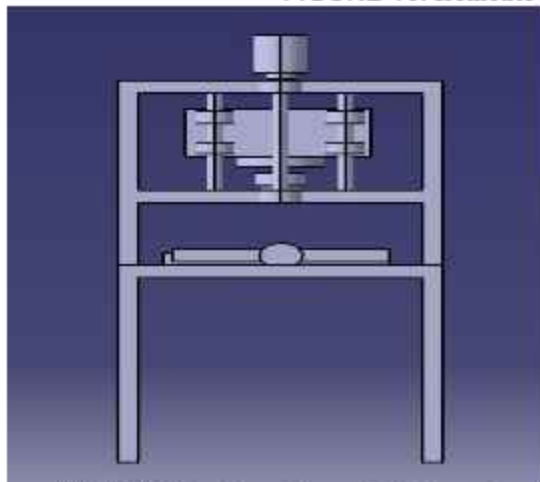

FIGURE 11:: Front View of Fabricated Machine Vice

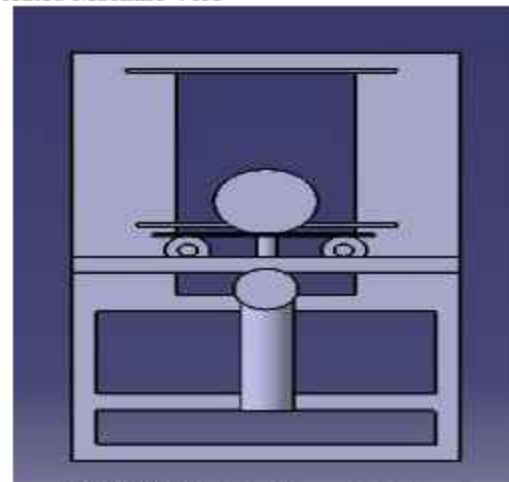

FIGURE 12: Top View of Fabricated Machine Vice

### 4. METHODS

All the components as per the specifications are procured. The design was carried out. As per the design specifications the frame was fabricated. On the frame the pneumatic cylinder was clamped where the cylinder

was tested successfully. To the cylinder piston a rectangular piece was welded which acts as the moving jaw. On the top of the frame a vertical frame was welded in which the drill motor battery was fixed. To the frame drill motor was fixed for the operation process. To move the drill up and down a screw shaft was welded and connected to the drill battery. Below the jaw a sensor is attached to indicate the presence of work piece. By using arduino a coding was done using Embedded C language. The circuit board was created on which 2 Dual-Channel Relay, Regulator, Arduino is present. To the circuit board the drill motor, sensor, solenoid valve was connected. After the finishing of the model it was tested successfully as shown in the figure 13.

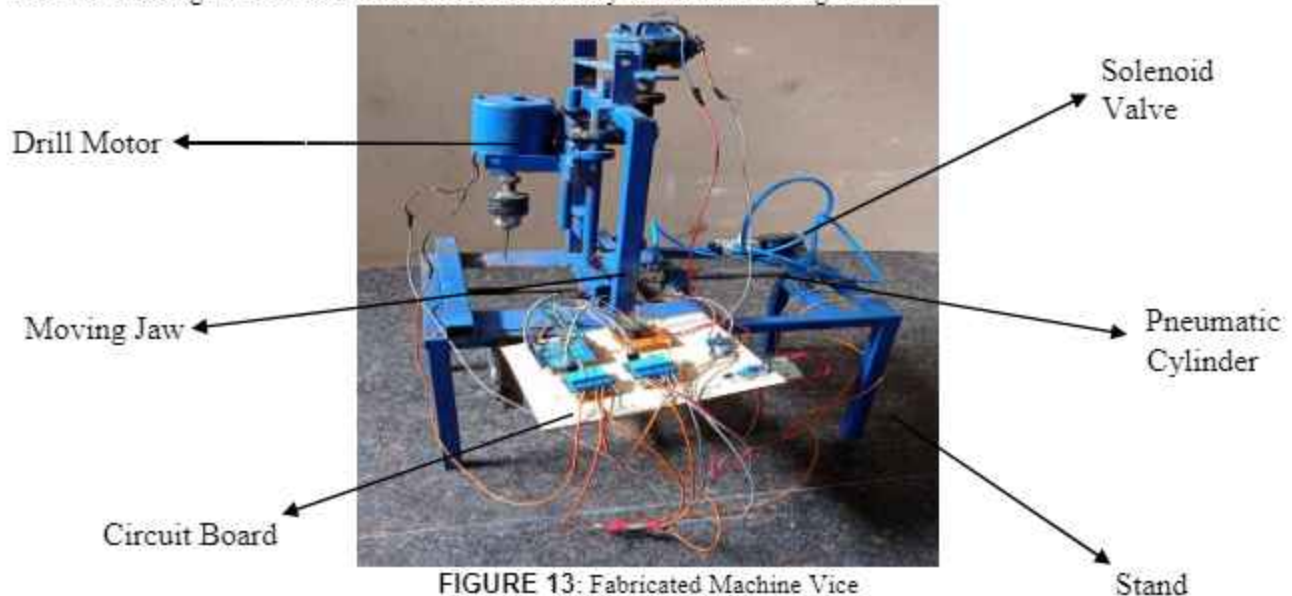

FIGURE 13: Fabricated Machine Vice

## 5. RESULTS & DISCUSSIONS

As per the standard specifications the machine vice is fabricated and tested. The size of the work piece mounted is 220x95x5mm. The maximum displacement the jaw can open is 130mm. The Sensor senses the work piece present between the jaws and indicates the circuit board to start the process. The solenoid valve allows the compressed air pass through the pneumatic cylinder where it moves forward clamping the work piece rigidly. The circuit board starts the drill motor in which the drilling operation is executed. After the operation is completed the jaw will unclamp the work piece.

## 6. CONCLUSIONS

Semi-Automated Machine Vice is fabricated according to the design specifications and it was tested by mounting a work piece of 220x95x5mm on which the drill operation was done successfully. With the help of mechanical motion obtained due to the application of pneumatic force the vice can be clamped. By this, it reduces the human power. The jaw will move faster and holds the work piece and it returns back to its position. Also this increases the accuracy and the time utilization is reduced.

## ACKNOWLEDGMENTS

We would like to express our gratitude to our Student Project Coordinator, Dr. Nirmala L, for having given this opportunity and support to carry out our project work.

## REFERENCES

- [1]. Anuchandran C, Praveen M, Karthikeyan R, Arun R, K Marimuthu, "Design and Fabrication of Automatic Machine Vice using Microcontroller", IJSRD - International Journal for Scientific Research & Development Vol. 5, Issue 07, 2017.
- [2]. P Sivasankaran, Thiyagarjan M, Vignesh N, Ajith Kumar A, "Design and Optimization of assembly time of screw less machine vice using FDA approach", International Journal of engineering and management research volume -7, Issue-5, September – October 2017.
- [3]. Essam Ali Al-Bahkali, Adel Taha Abbas, Failure analysis of vise jaw holders for hacksaw machine", Department of Mechanical Engineering, Engineering College, King Saud University, P.O. Box 800, Riyadh 11421, Saudi Arabia received 1 September 2015; accepted 23 December 2015.
- [4]. K ViswanathAllamraju, Rithvik Reddy Polusani, Vutakuri Sai Ranganath, Banda Venkateshwar Reddy, Ambati Pavan Kumar, "Design for Manufacturing and Analysis of Motorized Bench Vice", International Journal of Innovative Technology and Exploring Engineering (IJITEE) ISSN: 2278-3075, Volume-9 Issue-7, May 2020.

- [5]. Dr. S K Patel, "Design and fabrication of holding work piece for Drilling and milling purpose", Department of mechanical NIT Rourkela – 769008, 2013-2014.
- [6]. P Sivasankaran, "Design and Analysis of Modular Fixture for Machine Vice", International Journal of Industrial & Production Engineering & Technology. ISSN 2249-4219 Volume 8, Number 1 (2018).
- [7]. Asst. Professor, Dept. of Mechanical Engg Dr. Babasaheb Ambedkar, "Manufacturing of Components of Modified Bench Vice on Rapid Prototype Machine", International Journal of Application or Innovation in Engineering & Management (IJAIEM).
- [8]. Prof. Rushikesh D Sonar, Milind Y Patil, Karan B Bandawane, Vaibhav A Bhandare, Darshan M Chaudhai, "Pneumatic Operated Vice and Jack", IJARIE-ISSN(O) Vol-6 Issue-2 2020.
- [9]. Prof. Jatin Gulati, Dhananjay Kumar, Sagar Gupta, "Pneumatic Bench Vice Model, Department of Mechanical & Automation Engineering", G B Pant Government Engineering College, New Delhi-110020, November 2012.
- [10]. Prof. Priyanka Chavan, Shwetha Desale, Gayatri Fegade, Meghana Kakade, Prajakta Bhosale, "Review on Machine Vice and detailed study of Hydraulic Machine Vice", Department of Mechanical Engineering, Pimpri Chinchwad College of Engineering & Research, Maharashtra, India.

## DESIGN AND FABRICATION OF SOIL MOISTURE SENSING ROBOT

Hemanth Kumar M P<sup>1</sup>, Kaushal S<sup>1</sup>, Nilotpal Das<sup>1</sup>, Yogesh H M<sup>1</sup>, Manjunath B R<sup>2</sup>

<sup>1</sup> Students, <sup>2</sup> Assistant Professor  
Department of Mechanical Engineering  
K.S. Institute of Technology Bangalore -560109

### ABSTRACT

*Our country India is an agricultural country. Almost 64.9% of people are dependent on the agriculture but due to abrupt climate change and global warming the farmer are not able to provide proper nutrition and minerals to the plants which can be obtained from irrigation. So In this project we are designing and fabricating the soil moisture sensing robot. "Soil moisture sensing robot" is automated irrigation vehicle using Arduino microcontroller (ESP8266) system which is cost effective and can be used farm field. The proposed system is developed to automatically water the plants when the soil moisture sensor will detect the soil is insufficient of water by using the Arduino as the centre core. The soil moisture sensing robot is a fully functional prototype which consist of soil moisture sensor, the android phone is used to display the whether the soil is hydrated or not and the pump status. The application (blynk) is used to control the on/off switch of the water pump. When the soil moisture sensor senses the dry soil, it will show the weather the soil is hydrated or not in the android phone, and the application will switch on the water pump automatically to start the watering process and vice versa.*

**Keyword:** -Arduino, Microcontroller, Pump, Android phone

### 1. INTRODUCTION

Irrigation is the major part in the agriculture. Manual watering of the plants in the farming field requires more time and labour. In last few years many devices and technologies are been used by the farmer to provide automation in the farming which reduces the effort and can be time consuming for them. The purpose of making the project is to build soil moisture sensing robot which is able to detect whether the soil is hydrated or not, whatever the result is achieved it is displayed on the screen of the phone. If the soil is not hydrated then it will show the message that it is not hydrated after this use of pump come into the picture

Microcontroller based soil moisture sensing robot allows a simple and low cost method for irrigating the crops the crops automatically. In the proposed system we use application (blynk) to display the information. In this project we are using soil moisture sensor for

irrigation purpose. In the project we are using Arduino Uno controller. For wireless communication, the hotspot of the phone

is turned ON which transmit status of sensor as well as receives the command from phone to turn ON and OFF the motor pump.



FIGURE 1. Soil moisture sensor

## 2. COMPONENTS

The components used in this project are:

### 2.1 DC Electric Motor

Dc motor or direct current (Fig 2) motor is a electrical machine which transforms electrical energy into mechanical energy. Dc motors are used in the application where high starting torque is required, and accurate speed control over variable voltage take place. The capacity of motor used in project is 60 rpm.



FIGURE 2. DC Electric motor

### 2.2 Node Microcontroller unit (MCU):

Node MCU is an open source platform based on ESP8266 which can connect objects and data transfer using the wifi control. The programming code is written for ESP8266 wifi chip using Arduino IDE, for which installation of ESP8266 libraries is needed.



FIGURE 3. Node Microcontroller unit

### 2.3 Lead acid battery:

Lead acid battery is the most commonly used battery which has long lifetime and low cost compared to other type of battery. They are used in back-up power supplies for smaller computer system and many more. The capacity of battery which we are using in the project is 6 V, 5 AH



FIGURE 4 .Lead acid battery

### 2.4 Arduino Uno

Arduino Uno is an open source hardware and software platform that is easy to use. Arduino boards are capable of reading analog or digital input signals from various sensors.



FIGURE 5.Arduino Uno

### 2.5 Soil Moisture Sensor:

Soil moisture sensor measure the water content in the soil and can be used to estimate the amount of water stored in the soil. It doesn't measure the moisture directly, it measure the change in some other soil property that is related to water content.

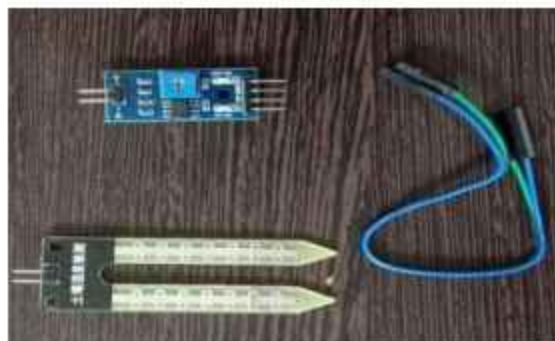

FIGURE 6. Soil moisture with module

### 3. METHODOLOGY



FIGURE 7. Using the component the product is assembled

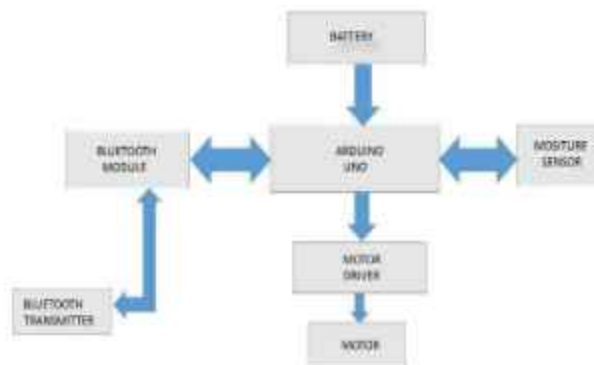

FIGURE 8. Block diagram

- Initially the battery (lead acid) is used to switch ON the system, once the system is On Arduino Uno start to operate.
- Since all the instruction (Input) are inserted in the Arduino Uno it will control the working of Bluetooth module as well as Moisture Sensor.
- Moisture sensor is used to detect the whether the soil is hydrated or not.
- Bluetooth module (hotspot) is used to transmit the message on the screen of the user.
- If the soil is not hydrated then watering in the soil can be done by the help of pump.
- The motor driver acts as the interface between the motor and control circuit (Arduino Uno) whatever the instruction is provided the motor driver help motor to work according to it.

### 4. RESULT

The soil moisture connected to an Arduino which is in turn interface with android application using Wi-Fi shield. Soil moisture is continuously monitored by sensor and the output displayed on the screen.

### 5. CONCLUSIONS

The introduced automated system is able to reduce the man efforts, wastage of water as well as power consumption and helps in obtaining good yield. The Bluetooth controlled (hotspot) is helpful in detecting the status of the soil by sitting away from the field. Soil moisture sensor helps in providing the better irrigation system and good crops with fewer inputs.

### REFERENCES

- [1] J. M. Corchado, J. Bajo, D. I. Tapia, and A. Abraham, —Using heterogeneous wireless sensor networks in a telemonitoring system for healthcare, | IEEE Trans. Inf. Technol. Biomed., vol. 14, no. 2, pp. 234–240, Mar. 2010. G.
- [2] X. Lee, K. S. Low, and T. Taher, —Unrestrained measurement of arm motion based on a wearable wireless sensor network, IEEE Trans. Instrum. Meas., vol. 59, no. 5, pp. 1309–1317, May 2010.
- [3] D.-M. Han and J.-H. Lim, —Smart home energy management system using IEEE 802.15.4 and ZigBee, | IEEE Trans. Consum. Electron., vol. 56, no. 3, pp. 1403–1410, Aug. 2010.
- [4] C. Gomez and J. Paradells, —Wireless home automation networks: A survey of architectures and technologies, | IEEE Commun. Mag., vol. 48, no. 6, pp. 92–101, Jun. 2010.



**REVIEW ON THE DEVELOPMENT OF ALUMINIUM ALLOY (6061) REINFORCED WITH ZrO<sub>2</sub>****Sudhamshu A C<sup>1</sup>, Pruthvi Gowda V<sup>1</sup>, Jayasurya K S<sup>1</sup>, Hrithik B N<sup>1</sup> and Shivakumar S<sup>2</sup>**

<sup>1</sup>Students, <sup>2</sup>Assistant Professor  
Department of Mechanical Engineering, Sir MVIT, Bangalore  
E-mail: vpruthvigowda@gmail.com

**ABSTRACT**

This Paper involves the review on the development of Aluminum alloy (6061) using forging process. The Standard Al 6061 alloy ingots was melted and super-heated in the electrical resistance furnace for about 8 hours at 750°C. The superheated melt was reinforced with zirconium dioxide in 3% and 6% weight proportions. The molten metal was poured into a cylindrical rod die of dimensions 300mm x 20mm and allowed to solidify at ambient temperature. The cast specimens were later forged for comparison study purposes. The microstructure and mechanical characterization of forged and unforged cast specimens. The microstructural characterization of forged cast sample exhibits fine grain structure with spherical morphology of secondary magnesium and silicon magnesium and silicon phase in the Al matrix whereas the unforged cast sample indicates coarse with dendrite type morphology. The strength results in terms of tensile of forged cast specimen reveals significant improvement in the tensile strength over the unforged cast specimens due to unforged cast specimen due to refined grain structure. The hardness results in terms of brinell hardness of reinforced specimens showed decrement compared to their base alloy.

**Keywords:** Aluminium 6061 alloy, ZrO<sub>2</sub>, stir casting, Optical microscopy, Keller's reagent

## DESIGN AND FABRICATION OF AIR BRAKE SYSTEM USING IC ENGINE EXHAUST GAS

Shrinidhi D<sup>1</sup>, Swasthik D K<sup>1</sup>, Uday Kiran P<sup>1</sup>, Ujwal N<sup>1</sup>, Dr. Saleem Khan<sup>2</sup>

<sup>1</sup> Students, <sup>2</sup> Assistant professor  
Department of Mechanical Engineering,  
K.S. Institute of Technology, Bengaluru, Karnataka.

### ABSTRACT

The aim of this project is to design and fabricate an Air Brake System based on Exhaust gases of an IC engine. The main objective is to reduce the workloads of the engine drive to operate the air compressor, because the compressor is not operated by the engine drive. A turbine is placed in the path of exhaust from the engine. The turbine is connected to a dynamo by means of coupling, which is used to generate power. Depending upon the airflow the turbine will start rotating, and then the dynamo will also start to rotate. A dynamo is a device which is used to convert the kinetic energy into electrical energy. The generated power can be stored in the battery and then this electric power has loaded to the DC compressor. The air compressor compresses the atmospheric air and it stored in the air tank and the air tank has pressure relief valve to control the pressure in the tank. The air tank supplies the compressed pneumatic power to the pneumatic actuator through solenoid valve to apply brake. The pneumatic actuator is a double acting cylinder which converts pneumatic pressure into linear motion. The generated electric power from the turbine used to compress the air in the DC compressor then supplied the pneumatic power to the air braking system. The exhaust gas was effectively utilized to perform the air braking system in addition to the conventional braking system and found the improvement in the braking performance.

**Keyword:** Air Brake, Exhaust, Pneumatic actuator, Dynamo, Solenoid valve, Kinetic energy.

### 1. INTRODUCTION

A **brake** is a mechanical device that inhibits motion by absorbing energy from a moving system. It is used for slowing or stopping a moving vehicle, wheel, axle, or to prevent its motion, most often accomplished by means of friction.

Most brakes commonly use **friction** between two surfaces pressed together to convert the **kinetic energy** of the moving object into heat, though other methods of energy conversion may be employed. For example, regenerative braking converts much of the energy to electrical energy.

Friction brakes on automobiles store braking heat in the drum brake or disc brake while braking then conduct it to the air gradually. When traveling downhill some vehicles can use their engines to brake.

An **air brake** or, more formally, a **compressed air brake system**, is a type of friction brake for vehicles in which compressed air pressing on a piston is used to apply the pressure to the brake pad needed to stop the vehicle. Air brakes are used in large heavy vehicles, particularly those having multiple trailers which must be linked into the brake system, such as trucks, buses, trailers, and semi-trailers in addition to their use in railroad trains [1].

### 2. MATERIALS AND METHODOLOGY

#### 2.1 ENGINE

As shown in figure 2.1, an engine is a machine designed to convert chemical energy into useful mechanical motion. Heat engines, including internal combustion engines and external combustion engines (such as steam engines) burn a fuel to create heat, which then creates motion. The internal combustion engine is classified into two types and they are diesel engine and petrol engine. Originally, an engine was a mechanical device that converted force into motion [3].

In this project, we use 59.9cc Spark Ignition four stroke single cylinder engine. it consists of a piston that moves within the cylinder fitted with two valves. The distance moved in one direction is called stroke and the cylinder diameter is bore. The piston is said to be at the top dead centre position the volume of the cylinder is minimum.



Fig 2.1, IC Engine

#### 2.2 AIR BRAKE SYSTEM

Air brake systems are typically used on heavy trucks and buses. The system consists of service brakes, parking brakes, a control pedal, and an air storage tank. For the parking brake, there's a disc or drum brake arrangement which is designed to be held in the 'applied' position by spring pressure. Air pressure must be produced to release these "spring break" parking brakes. For the service brakes (the ones used while driving for slowing or stopping) to be applied, the brake pedal is pushed, routing the air under pressure (approx. 100–120 psi or 690–830 kPa or 6.89–8.27 bar) [2] to the brake chamber, causing the brake to be engaged. Most types of truck air brakes are drum brakes, though there is an increasing trend towards the use of disc brakes in this application. Figure 2.2 shows the nomenclature of a typical air brake system.

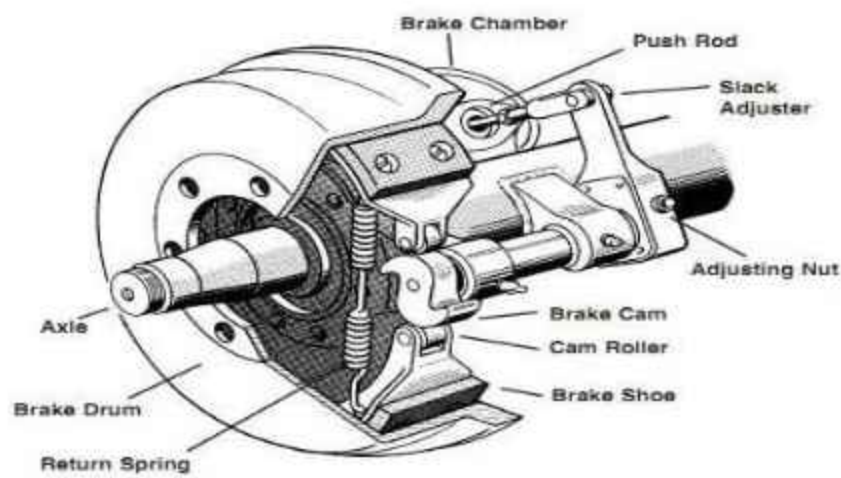

Fig 2.2, Air brake system.

### 2.3 AIR COMPRESSOR

Figure 2.3 shows an air compressor which is a device that converts power (using an electric motor, diesel or gasoline engine, etc.) into potential energy stored in pressurized air (i.e., compressed air). By one of several methods, an air compressor forces more and more air into a storage tank, increasing the pressure. When tank pressure reaches its engineered upper limit the air compressor shuts off. The compressed air, then, is held in the tank until called into use. The energy contained in the compressed air can be used for a variety of applications, utilizing the kinetic energy of the air as it is released and the tank depressurizes. When tank pressure reaches its lower limit, the air compressor turns on again and re-pressurizes the tank.

An air compressor must be differentiated from an air pump which merely pumps air from one context (often the surrounding environment) into another (such as an inflatable mattress, an aquarium, etc.). Air pumps do not contain an air tank for storing pressurized air and are generally much slower, quieter, and less expensive to own and operate than an air compressor. The compressor that we are using in the project has a capacity to withstand 300psi of pressure.



Fig 2.3, Air compressor

### 2.4 PNEUMATIC CYLINDER

As shown in figure 2.4, a pneumatic cylinder(s) (sometimes known as air cylinders) are mechanical devices which use the power of compressed gas to produce a force in a reciprocating linear motion.

Like hydraulic cylinders, something forces a piston to move in the desired direction. The piston is a disc or cylinder, and the piston rod transfers the force it develops to the object to be moved. Engineers sometimes prefer to use pneumatics because they are quieter, cleaner, and do not require large amounts of space for fluid storage.

Because the operating fluid is a gas, leakage from a pneumatic cylinder will not drip out and contaminate the surroundings, making pneumatics more desirable where cleanliness is a requirement.



Fig 2.4, Pneumatic cylinder.

### 2.5 SOLENOID VALVE

A solenoid valve is an electromechanically operated valve. The valve is controlled by an electric current through a solenoid: in the case of a two-port valve the flow is switched on or off; in the case of a three-port valve, the outflow is switched between the two outlet ports. Multiple solenoid valves can be placed together on a manifold.

Solenoid valves are the most frequently used control elements in fluidics. Their tasks are to shut off, release, dose, distribute or mix fluids. They are found in many application areas. Solenoids offer fast and safe switching, high reliability, long service life, good medium compatibility of the materials used, low control power and compact design [5].

Besides the plunger-type actuator which is used most frequently, pivoted-armature actuators and rocker actuators are also used.



Fig 2.5, Solenoid valve.

## 2.6 BATTERY

A rechargeable battery, storage battery, secondary cell, or accumulator is a type of electrical battery which can be charged, discharged into a load, and recharged many times, as opposed to a disposable or primary battery, which is supplied fully charged and discarded after use. It is composed of one or more electrochemical cells. The term "accumulator" is used as it accumulates and stores energy through a reversible electrochemical reaction. Rechargeable batteries are produced in many different shapes and sizes, ranging from button cells to megawatt systems connected to stabilize an electrical distribution network. Several different combinations of electrode materials and electrolytes are used, including lead-acid, nickel-cadmium (Ni-Cd), nickel-metal hydride (NiMH), lithium-ion (Li-ion), and lithium-ion polymer (Li-ion polymer). Figure 2.6 shows a typical rechargeable battery.



Fig 2.6, Battery

## 2.7 PNEUMATIC PIPES

Pneumatic tubes (or capsule pipelines; also known as pneumatic tube transport or PTT) as shown in figure 2.7, are systems that propel cylindrical containers through networks of tubes by compressed air or by partial vacuum. They are used for transporting solid objects, as opposed to conventional pipelines, which transport fluids. Pneumatic tube networks gained acceptance in the late 19th and early 20th centuries for offices that needed to transport small, urgent packages (such as mail, paperwork, or money) over relatively short distances (within a building, or at most, within a city). Some installations grew to great complexity, but were mostly superseded. In some settings, such as hospitals, they remain widespread and have been further extended and developed in the 21st century. We have used 8mm pneumatic pipes currently for the passage of air into the cylinder in order to actuate the movement.



Fig 2.7, Pneumatic pipes.

## 2.8 DYNAMO

Dynamo is an electrical generator. This dynamo produces direct current with the use of a commutator. Dynamo was the first generator capable of generating power in the industries. The dynamo uses rotating coils of wire and magnetic fields to convert mechanical rotation into a pulsing direct electric current. A dynamo machine consists of a stationary structure, called the stator, which provides a constant magnetic field, and a set of rotating windings called the armature which turn within that field. On small machines the constant magnetic field may be provided by one or more permanent magnets, larger machines have the constant magnetic field provided by one or more electromagnets, which are usually called field coils. The commutator was needed to produce direct current. When a loop of wire rotates in a magnetic field, the potential induced in it reverses with each half turn, generating an alternating current. However, in the early days of electric experimentation, alternating current generally had no known use. The few uses for electricity, such as electroplating, used direct current provided by messy liquid batteries. Dynamos were invented as a replacement for batteries. The commutator is a set of contacts mounted on the machine's shaft, which reverses the connection of the windings to the external circuit when the potential reverses, so instead of alternating current, a pulsing direct current is produced.

## 2.9 METHODOLOGY

An IC engine powered by petrol is used to produce exhaust gas. Here we are placing a turbine in the path of exhaust from the silencer. The turbine is connected to a dynamo, which is used to generate power.

Depending upon the airflow the turbine will start rotating thus rotating the dynamo. A dynamo is a device which is used to convert the kinetic energy into electrical energy. The generated electric power is stored in a battery after rectification. Thus, the stored electrical power is used to run the DC compressor. The compressor compresses the air from the exhaust. When the brake is applied the 5/2 solenoid valve is activated and it allows the air to actuate the pneumatic cylinder thus the brake is applied [1]. Figure 2.9 shows the block diagram of the workflow of the project.

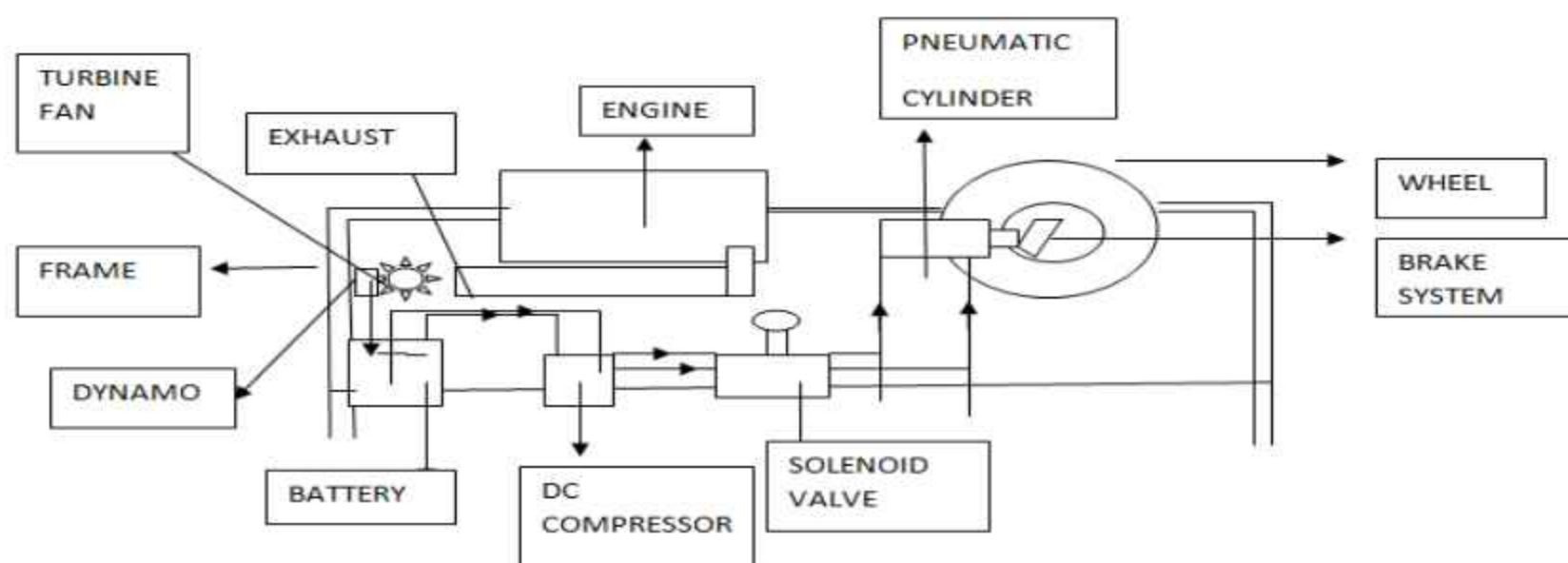

Fig 2.9. Block diagram.

### 3. RESULTS AND DISCUSSIONS

The temperature and pressure increase when the load is increased depending upon the operating conditions. Pressure and temperature will vary depending on load conditions as well as voltage will vary. Therefore, the voltage should be checked by using a multi-meter. The voltage is measured by using a multi-meter during variable condition. The below calculation is calculated based on the literature survey. The battery is used for charging and it is tested. Voltage is measured by using a voltmeter. The current is measured by ammeter while energy is recovered from the exhaust gas. The area of turbine is measured and calculated on the basis of design criteria. The power available at the turbine is calculated by below formula.

#### Formula:

Swept Area,  $A = \pi r^2$   
 $R = \text{radius of turbine} = 27.5 \times 10^{-3} \text{m}$   
 Velocity of the Turbine  $= (\pi \times D \times N) / 60$   
 Where,  
 $D = \text{turbine diameter} = 55 \times 10^{-3} \text{m}$   
 $N = \text{rpm}$   
 $C_p = \text{power co-efficient}$   
 Turbine power,  
 $P = \left(\frac{1}{2}\right) \times \text{Density} \times (\text{Velocity})^3 \times C_p \times \text{Area}$

#### Model Calculation:

Swept area (turbine),  
 $A = \pi r^2$   
 $= \pi \times (27.5 \times 10^{-3})^2$   
 $= 2.37 \times 10^{-3} \text{m}^2$

Velocity of the turbine, Velocity

$$= \frac{\pi \times D \times N}{60}$$

$$= \frac{\pi \times 55 \times 10^{-3} \times 95}{60}$$

$$= 0.2735 \text{ m/s}$$

Power available at the turbine

$$= \left(\frac{1}{2}\right) \times \text{Density} \times \text{Area} \times (\text{Velocity})^3 \times c_p = 0.5 \times 1.25 \times 2.37 \times 10^{-3} \times (0.2735)^3 \times 0.5 = 1.51 \times 10^{-5} \text{watts.}$$

### 4. CONCLUSION

The above calculation show the result of our project i.e. in the 1<sup>st</sup> trial at RPM 1500 the dynamo rotated at the speed of an RPM 95 And power generate was  $1.51 \times 10^{-5}$  watts. We can conclude that whenever RPM of the engine is increased RPM of the dynamo will also increase and power generation will be more. We can also recover the energy that is being discharged from the exhaust gas without any change in performance.

### REFERENCES

- [1]. Srinivasa D, Karthik S T, Deepak M, Gowtham M, Sagar AS - Development and fabrication of air brake system using engine exhaust gas- IOSR Journal Of Mechanical and Civil Engineering, Vol. 16 Issue-3 June 2019.
- [2]. Harsha B.T, G Rajesh, Arun Kumar K, Akash S M, Preethi Reddymasi - Fabrication of air brake system using engine exhaust gas.- International journal for technological research in engineering. Vol.6, Issue 9, May 2019
- [3]. N Abhishek, S Arul Prakash, S Manikandan, T P Suresh- Design and Fabrication of air brake system using engine exhaust gas- International research Journal of Engg. & Technology [IRJET] Vol. 8 Issue-4, April 2021.
- [4]. Sethuraman B.L., Sakthivel R, Gopal Krishnan E, Shree Ram Vishal- Design and implementation of secondary air brake system using engine exhaust gas- Journal of advanced engineering research, Vol 7, Issue 2 (2020)
- [5]. S Suresh, J.D Nallashivam, A Thrimoorthy- Pneumatic braking System- International journal of production technology and management(IJPTM) Vol.9, Issue 2, December 2018
- [6]. Md. Aftab Ali, Sanam Kothari, Kruthag Jariwala, Ratnadip Bhorge- Design and fabrication of air brake system using engine exhaust gas. - Journal of thermal energy system vol.4 Issue 2 (2019).

## CONCENTRATED SOLAR POWER ELECTRICITY GENERATOR

Anirudh R Srivatsa, Mohan Raju G, Navaneeth Krishna,  
Students

Department of Mechanical Engineering,  
K S Institute of Technology, Bangalore-560109, Karnataka, India

### ABSTRACT:

*This paper deals with the fabrication of a concentrated solar power electricity generator, since there is a scarcity of conventional energy resources, there is a need for the development and usage of renewable energy resources with a low initial investment. In this work, an attempt has been made to generate electricity from sunlight using mirrors and a black body. Here sunlight acts as the power source and the black body traps the heat which is intern used in converting water into super-heated steam. Here mirrors are replaced with PV cells where using mirrors the sunlight is reflected onto the black. Further, the generated steam runs over the turbine resulting in electricity generation*

Keywords: CSP generator, conventional, renewable, mirror, black body, turbine

### 1. INTRODUCTION

Renewable energy resource has become a progressive subject in the research and scientific community. The idea is to build an energy resource that can generate a renewable source of energy using sunlight. The work is intended to convert solar energy into electrical energy in which solar PV cells will be replaced with mirrors. Using a combination of mirrors concentrated heat is generated using which water will be converted into steam which will run over a turbine generating electricity which can be used for day-to-day activities or can be stored. In this model PV cells are replaced with mirrors and a black body is present at the center containing water, sunlight is reflected onto the black body generating heat which converts water into steam over 30 minutes to one hour depending on the quantity of water and number of mirrors placed

### 2. DESCRIPTION OF COMPONENTS

#### 2.1 Components used

- Blackbody
- Mirror
- Motor
- Pressure regulator
- Voltmeter
- Led Bulb
- Propeller

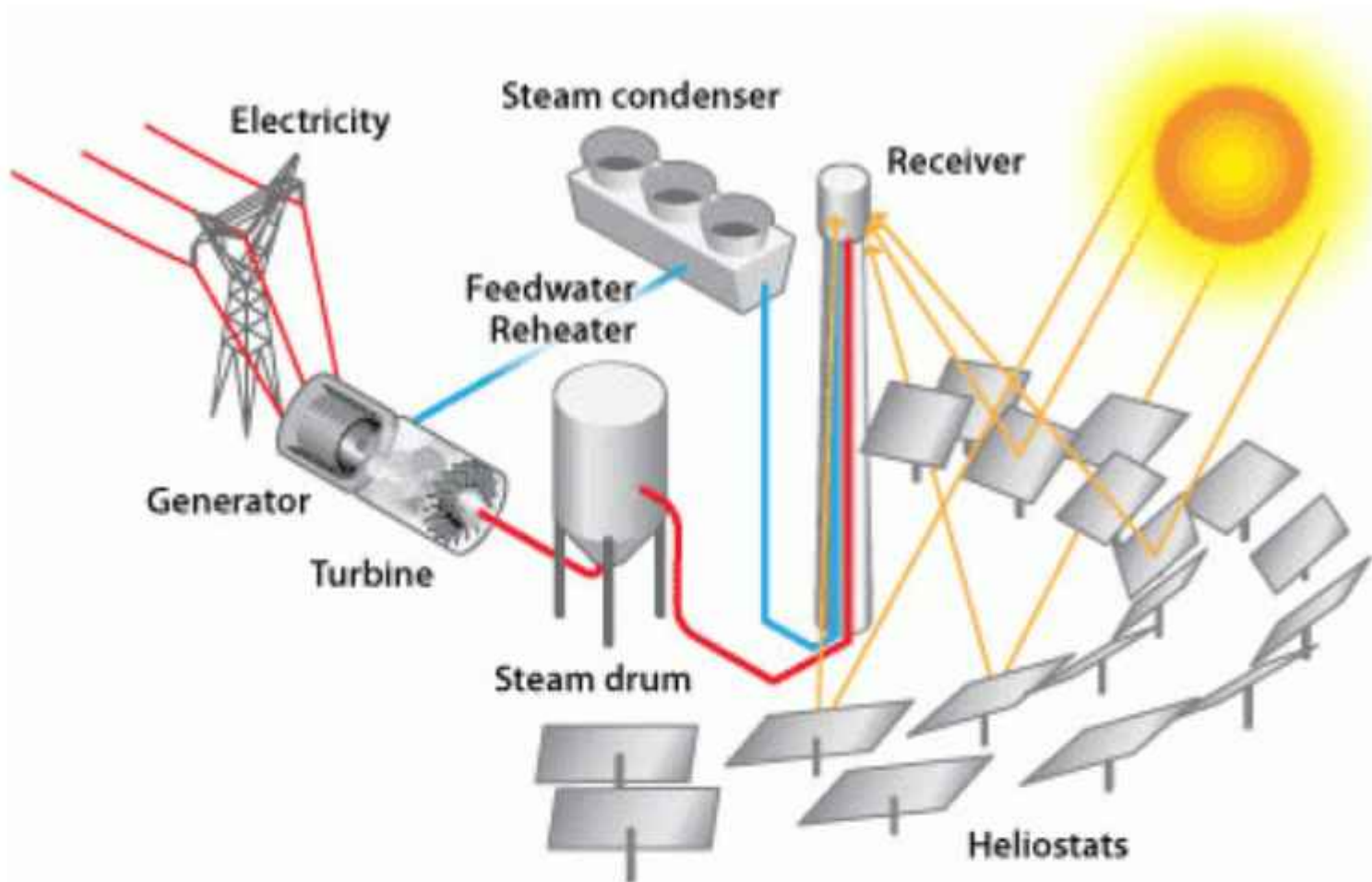

## 2.2 Blackbody

A black body or blackbody is an idealized physical body that absorbs all incident electromagnetic radiation, regardless of frequency or angle of incidence. The name "black body" is given because it absorbs all colors of light.

In our case, the black body absorbs all the sun rays falling on it that are reflected by the mirror and convert it into the form of heat



## 2.3 Pressure regulator

A pressure regulator is a valve that controls the pressure of a fluid or gas to the desired value, using negative feedback from the controlled pressure. Regulators are used for gases and liquids and can be an integral device.

A pressure regulator is a control valve that maintains the set pressure at its inlet side by opening to allow flow when the inlet pressure exceeds the set value.



## 2.4 Mirror

A mirror or looking glass is an object that reflects an image. Light consists of waves, and when light waves reflect off the flat surface of a mirror, those waves retain the same degree of curvature and vergence, in an equal yet opposite direction, as the

original waves, this phenomenon allows the mirror to reflect the sunlight onto the black body

### 2.5 DC Motor

A DC motor is any of a class of rotary electrical motors that converts direct current (DC) electrical energy into mechanical energy or vice versa.

In our model, it converts mechanical energy into electrical energy using the steam generated which basically replicates the functioning of a steam turbine



### 2.6 Voltmeter

A voltmeter is an instrument used for measuring electric potential difference between two points in an electric circuit. It is connected in parallel. It usually has a high resistance so that it takes negligible current from the circuit.

In this project voltmeter is connected in series with the DC motor which measure the current being generated.



### 2.7 LED Bulb

A light-emitting diode (LED) is a semiconductor light source that emits light when current flows through it. Electrons in the semiconductor recombine with electron holes, releasing energy in the form of photons. The color of the light is determined by the energy required for electrons to cross the band gap of the semiconductor. the electricity produced from the DC motor is given to the led bulb which indicated the generation of electricity.



## 3. RESULT & DISCUSSION

There are different types of CSP electricity generators but our model is based on a Solar tower where the black body will be placed on the tower at a height of 0.3 meters (30 centimeters) and a total of 60 mirrors will be placed in planetary form so that it can function round the clock.

The mirrors r split into 3 rows consisting of 24 in the first and second row and 12 in the third row inclined at an angle of 30 degrees 45 degrees and 60 degrees respectively, angles were determined based on the height of the tower and placement of the mirror.

Once the CSP generator is exposed to sunlight Considering the water temperature to be around 23–25 degrees Celsius it would take 35-40 minutes for the water inside the black body to reach 100 degrees and is converted into steam which comes out with high pressure from pressure switch which runs over the propellers which is connected to the DC motor.

As DC motor also works in reverse function due to the rotation of DC motor Small amount of voltage can be observed in the voltmeter which supplies power to the LED connected.

## ACKNOWLEDGMENTS

We have taken efforts in this project. However, it would not have been possible without the kind support and help of many individuals and organizations. We would like to extend my sincere thanks to all of them.

We are highly indebted to proof K Prasad Asst. Professor, K.S. Institute of technology, for his guidance and constant supervision as well as for providing necessary information regarding the project & also for their support in completing the project.

Our thanks and appreciations also go to my colleague in developing the project and people who have willingly helped me out with their abilities.



## VOICE CONTROLLED CAR USING ARDUINO- A Review

Jithan A, Madhu. V, Hemanth K., Nithesh S R.

Students

Department of Mechanical Engineering,  
K S Institute of Technology, Bangalore-560109, Karnataka, India

M Saravanan [1] has developed "Arduino Based Voice Controlled Robot car" (October 2020) The main goal of this device is to create a robot car that can be powered by a person's voice order. These systems are commonly referred to as Speech Controlled Automation Systems (SCAS). The above-mentioned device is a prototype of our design. A cell phone is used to operate the robot; there are several articles that demonstrate the contact between a robot and a smart phone. The specified task is carried out in this design using an android application and a HC -05 Bluetooth Module. Bluetooth technology facilitates communication between the software and the robot car. The module will receive the commands that are sent over the channel. The aim of a voice-controlled robotic vehicle (VCRV) is for it to listen to and respond to the user's commands.

Mrumal.K. Pathak [2] has "Robot Control Design Using Android Smartphone" (February 2015) The objective of this project is to build a robot which can be powered by an Android phone. In this design, the Android phone works as a remote control for the Robot. Bluetooth module and DC motors are interfaced to the microcontroller. The Bluetooth module sends the information from the Android phone to the controller. The controller is in charge of the robot's DC motors. In order to execute the project, the controller is loaded with a programming language in the Embedded "C" or "c++" or "java". languages. This paper describes how to monitor a robot with a handheld using Bluetooth communication, as well as some of the core concepts of Bluetooth technology and the compact and robot segments. It shows an analysis of robots enabled by a smartphone by moving the robot forward, backward, left, and right with an Android software like Micro controller or Bluetooth.

Shubh Srivastava [3] contributed "Voice controlled robot car using Arduino" (May 2020) The project's goal is to build a voice-controlled robotic car. Arduino microcontroller, motor drivers, and a Bluetooth module are used to power the device. Arduino is a piece of open- source hardware that can be used to create digital gadgets. A Bluetooth module is used to capture and read voice commands, allowing the control unit to communicate with the Bluetooth device. The controlling remote is a Bluetooth-enabled smart android smartphone. It is given a simple voice activated robotic vehicle. It constitutes of a mobile device that accepts voice commands and transmits them through Bluetooth to the Bluetooth module HC05.

Aditya Chaudhry [4] implemented "Arduino based voice-controlled Robot" (June 2019) This research paper proposes a method that focuses on the idea of controlling a robot with a voice signal. The voice control robot is merely an example of how to control the movements of a simple robot using common voice commands. In this system they have used ATmega3898P It's a microcontroller on a single chip. It has an 8-bit RISC processor core based on Harvard architecture. To monitor a robotic vehicle with our voice, we used a very reliable interface.

Parichart Leechor [5] has wrote "Operation of a Radio-Controlled Car by Voice Commands" (March 2010) The purpose of this research is to drive a radio-controlled car via voice commands (RC car). The experiment involved sending a user's voice commands to a device, which then converted them into digital data. Thereafter, the data output was converted into radio signal commands. Finally, an RC car was functioned using radio wave commands. The first feature is voice command recognition, for that they have adopted the Hidden Mark Model (HMM), which is one of multiple voice recognition technologies.

The second part is the hardware, which involves a system dual port and RC car communication. To commence, we

use signal processing theory to convert the human voice into a system digital signal. After that, the digital signal is

converted to radio waves and used to power an RC vehicle.

P. Mahesh Reddy [6]. Providing human labor is the biggest problem all over the world. With the help of this device, they can move in a wheel chair on their own by just giving voice commands through Bluetooth. If any obstacle is detected while moving it informs the user and stops. It also detects if any fire and smoke occur due to emergency, detects and informs the prescribed number to get the required help. First, all user

signals are converted to script using Google's speech to text converter, that is built into the app. The command's text form will be sent to the robotic car's Bluetooth module. This Bluetooth module enables the car's microcontroller to the Android app for transmitting data. When the micro-controller receives the text signal, it directs the robotic car to drive in the appropriate direction

Kirupa Ganapathy [7]. The voice directions are handled, utilizing an advanced mobile phone. The individual human right hand robot is created on a smaller scale controller based stage and can know about its present area. The viability of the voice control conveyed over a separation is estimated through numerous examinations. Execution assessment is completed with consequences of the underlying investigations. The developments to be forecasted are possibly referring to the applications in ventures, medical clinics and how, including the environmental laboratories

Anjali Verma [8]. The Android application (AMR- Voice) is connected to Bluetooth Module (HC - 05), which is directly connected to Arduino Uno R3. We give command to the robot and it performs work according to the given command. Voice Control Robot is much useful for those areas where humans can't reach. Robot can work in all type of situations like toxic area, in fire situations, polluted area and also on hills. This robot is very useful for those who is physically challenged. This robot is very small in size so we can use this project for spying or espial

Subankar Roy, [9] Tashi Rapden Wangchuk, Rajesh Bhatt, "Arduino Based Bluetooth Controlled Robot". A robot is usually an electro-mechanical machine guided by a

computer and electronic programming. Many robots are manufactured for manufacturing purposes and are found in factories around the world. The design of the latest inverted ROBOT that can be controlled using the APP for Android mobile. And in which we use Bluetooth communication for Arduino UNO and Android interfaces. Arduino can be interfaced on a Bluetooth module despite the UROT protocol. The robot motion can be controlled according to the command received from Android. The consistent output of a robotic system does not match with quality and repetition. These robots can be recyclable and can be interchanged to provide multiple applications.

Anurag Mishra[10]. This paper describes easy and simple hardware for implementation of Face, Object and speech detection and recognition. Using an online cloud server. The speech signal commands converted to text form are communicated to the robot over a Bluetooth network. Svitlana Maksymova[11]. The article considers robot voice control software development. Program main window is displayed, as well as the recognition window, in which the operator can check the correct recognition and interpretation of voice commands. We consider the controls that are present on these windows. To control the robot, it is necessary to compile a library of words that the operator can input to achieve the set goals. The main elements of this library are discussed and defined through the article. Also, the commands that may be needed in the case of interactive correction of actions are considered. Akshay Kumar [12]. This project presents a modern approach to remote and boundaries surveillance using a multi-functional robot based on current IOT. This robot continuously watches and sends live streaming to an authorized person.

Here, the MJPG streamer is used to visualize the live video installed in the raspberry pi. The VNC software is installed on the local computer and connects to the raspberry pi that must be installed on the remote computer. The server transmits a duplicate of the display screen. This process includes a smart surveillance robot for military application. With the guidance of this robot, we can assess the current state of the border area in real time without depending on any human source. The surveillance robot provides us with live streaming video in response to our commands. The goal of this project is to create an equipment circuit that allows people to control robots or other home machinery using their voices. Smart phones are becoming increasingly powerful devices with the ability to interact with other appliances via Bluetooth, wifi, and other means. Bluetooth, despite being a low-cost mode of communication, provides a strong mode of connection.

H.I.Darwish[13]. This project will use Google voice recognition to analyze human speech and transfer it to text using the Google voice to text API. The converted text will be sent to the microcontroller as a code using the HC-05 Bluetooth. The HC-05 will act as a receiver (Rx) for this function, obtaining the code from the smart phone and forwarding it to the decode circuit. Via the UART protocol, a controller can communicate with the Bluetooth module. The aim of this project is to develop an equipment circuit that allows user to manage robots with their voices. The main part of the project to control the robot from any remote location is the creation of a web page. It will be necessary to construct a single platform from which we will access the robot. We can control the direction of the motor and the position of the camera from the web page, as well as monitor the video feed. It will be necessary to secure our website from anyone.

B.Mert[14]. In this paper, they develop a prototype of a smart robot whose movements are controlled by voice-commands and gesture- commands. Voice-command controls include an Android OS-based smart phone. Gesture-commands can be delivered either by hand using an accelerometer, or by tilt-getting using a smart phone's gravity sensor. Robot's body movements are controlled by the voice- commands, and its arms and claws are controlled by the gesture- commands. The robot's body will move backwards and forwards, left and right, and stop, on several things. The established robot's body movements are controlled by an Android OS-based smart-phone application called "AMR Voice."Using an online cloud server, this pre- developed Android application converts speech signal commands to text. The voice commands are processed and converted to text, which will then be sent to a Bluetooth module on board the robot through the smart phone's Bluetooth network link. The link manager protocol (LMP) is used to encrypt, exchange, and authenticate control signals sent to the robot.

T.L.Chien [15]. This robotic is designed to operate a vehicle using a Bluetooth module and a human voice command. The robot is received commands via an Android device. The Android application (AMR – Voice) is connected to a Bluetooth Module (HC – 05), which is in turn linked to an Arduino Uno R3 directly. A Voice Control Robot is extremely useful in environments where humans are unable to enter. While this robot is so small, we can use it for monitoring or spying. The Voice Control Robot is operated by a voice command given directly to the robot by the user. An Android application which serves as a transmitter is enabled on the handset. This android module offers the commands. The Arduino is understood using a Bluetooth module by the Android application AMR Voice. The Arduino is connected to a Bluetooth module (HC-05). These robotic aids can be used in various sectors, such as production, defence etc. for the shaping, production and tooling of materials.

#### REFERENCE:

- [1] M Saravanan et al developed "Arduino Based Voice Controlled Robot Vehicle" (October 2020).
- [2] Mrumal.K.Pathak et al wrote "Robot Control Design Using Android Smartphone" (February 2015).
- [3] Shubh Srivastava et al contributed "Voice controlled robot car using Arduino" (May 2020).
- [4] Aditya Chaudhry et al implemented "Arduino based voice-controlled Robot" (June 2019).
- [5] Parichart Leechor et al wrote "Operation of a Radio-Controlled Car by Voice Commands" (March 2010).
- [6] P. Mahesh Reddy, Suram Pavan Kalyan Reddy, G R Sai Karthik, Priya B.K,2020, Intuitive Voice Controlled Robot for Obstacle, Smoke and Fire Detection for Physically Challenged People, *International Conference on Trends in Electronics and Informatics (ICOEI)*, ISBN: 978-1-7281-5518-0.
- [7] M.Bhanu chandu, Kirupa Ganapathy,2020, Voice Controlled Human Assistance Robot, *International Conference on Advanced Computing & Communication Systems (ICACCS)*, 978-1-7281-5197-7/20.
- [8] Anjali Verma, Deepak Kumar, Hariom Maurya , Anuj Kumar, Mr. Prabhakant Dwivedi,2020, Voice Control Robot Using Arduino, *International Research Journal of Modernization in Engineering Technology and Science*, Vol 02/Issue:04, e-ISSN: 2582-5208.
- [9] Subankar Roy, Tashi Rapden Wangchuk, Rajesh Bhatt, "Arduino Based Bluetooth Controlled Robot", *International Journal of Engineering Trends and Technology (IJETT)*, V32(5),216-219 February 2016.
- [10] Anurag Mishra, Pooja Makula, Akshay Kumar, Krit karan, and V.K. Mittal, 2015, A voice controlled personal assistant robot, *International Conference on Industrial Instrumentation and Control (ICIIC)*.
- [11] Svitlana Maksymova, Rami Matarneh, Vyacheslav V. Lyashenko,2017, Software for Voice Control Robot: Example of Implementation, *Open Access Library Journal*.
- [12] Jayant Nivritti Patil , Akshay Kumar : "Advanced Rescue and Monitoring Robot for Coal Mine" in *International Research Journal of Engineering and Technology (IRJET)*, vol: 04 issue 7 July 2017.
- [13] S. D. Mitragotri, Dr.A.R. Karwankar , H.I.Darwish Coal Mine Robot For Detection of Hazardous Gas in *International Journal of Advanced Research in Electrical, Electronics and Instrumentation Engineering* Vol. 5, Issue 4, April 2016.
- [14] T S Kumar Reddy, G Bala Siva Krishna "Hazardous Gas Detecting Rescue Robot In Coal Mines " in *International Journal of Mechanical And Production Engineering*, Volume- 2, Issue- 5, May-2014.
- [15] Chinmay Kulkarni, Suhas Grama, Pramod Gubbi Suresh, " Surveillance Robot Using Arduino Microcontroller, Android APIs and the Internet", *IEEE First International Conference on Systems Informatics*, 2014.

## COMPUTATIONAL FLUID DYNAMICS ANALYSIS OF BLADES FOR VERTICAL AXIS WIND TURBINE

Janardhan R<sup>1</sup>, Tejas A B<sup>1</sup>, Sharan V K<sup>1</sup>, Sankarshan D<sup>1</sup>, Dr Saleem Khan<sup>2</sup>

<sup>1</sup>Students, <sup>2</sup>Associate Professor

Department of Mechanical Engineering,

K S Institute of Technology, Bangalore-560109, Karnataka, India

### ABSTRACT

*This paper deals with alternate source of energy, since there is a scarcity of conventional energy resources now a days, there is a need for developing and usage of renewable energy resource. In this work an attempt has been made to convert the energy released by people while driving around in city or highways. Here vehicles acts as the power source and the vertical axis wind turbine acts as source of power generation. Energy can be harvested using vertical axis wind turbines (VAWT) placed on the sides of the highways to make use of the vehicles moving in both directions. This work presents an experimental study of using a three-bladed helical VAWT specially designed and manufactured for producing electrical energy from wind energy of moving cars on highways for lighting purposes such as the highway lights, traffic signals, and light guide lines.*

**Keywords:** Source of energy, conventional, renewable, highways, vertical axis wind turbine

### 1. INTRODUCTION

Energy can be defined as the ability to do work. Modern civilization is possible because people have learned how to change energy from one form to another and then use it to do work. People use energy to walk and bicycle, to move cars along roads and boats through water, to cook food on stoves, to make ice in freezers, to light our homes and offices, to manufacture products, and to send astronauts into space.

These forms of energy can be grouped into two general types of energy for doing work:

- Potential or stored energy
- Kinetic or working energy

Energy can be converted from one form to another. For example, the food a person eats contains chemical energy, and a person's body stores this energy until he or she uses it as kinetic energy during work or play. The stored chemical energy in coal or natural gas and the kinetic energy of water flowing in rivers can be converted to electrical energy, which in turn can be converted to light and heat. There are many different sources of energy, which can be divided into two basic categories:

Renewable energy sources,

Non-renewable energy sources,

#### Wind turbine

Motivation for designing a vertical axis wind turbine is to contribute towards the global trend in wind energy production in a feasible way. Wind turbines are traditionally employed in rural areas; the goal of this research is to design a vertical axis wind turbine that can be used in cities. In particular, the turbines will use the wind draft created by vehicles on the highway to generate electricity. The idea is to offset the amount of pollution created by burning fossil fuels by introducing a potential source of clean energy.

The vertical wind turbine design is selected because they are capable of capturing wind in any direction. The helical blade shape of the wind turbine is much quieter than the turbine with traditional blades, because they have slower speed along the blade tip. They are easy to install, they have low maintenance cost, and pose low risk for human and birds because the blades move at relatively low speed. They can be placed lower to the ground and rooftops, and have high efficiency because the helical blades design gets higher wind capture. Therefore, in this research a three-bladed helical VAWT prototype is designed and implemented on the Kuwait highway King Fahad Bin Abdul Aziz. This is one of Kuwait's high traffic roads where the demand for the lighting electric power is high.

### 2. METHODOLOGY

- > Initially the natural wind speed in a particular location was observed for a week in order to design a wind turbine.
- > Considering wind direction and velocity of wind, 5 blade geometric profiles were considered to see which suitable for the application.

- CFD analysis is conducted on selected 5 blade geometric profiles with suitable boundary conditions.
- There are three boundary conditions to be considered while conducting CFD analysis for the particular problem and they are:
  - Inlet condition
  - Wall boundary condition
  - Outlet condition
- Constant wind velocity of 1m/s is applied on all the types of blades while simulating.
- The pressure, velocity and direction of wind are tabulated.

Blade Type 1:

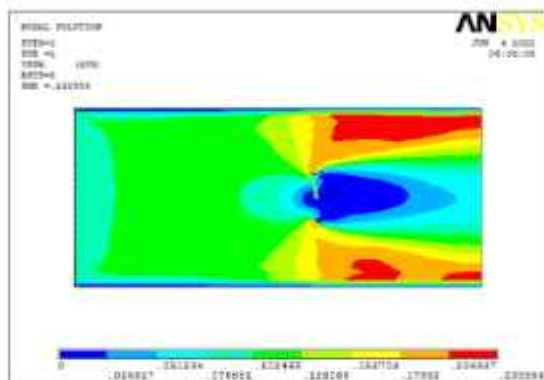

FIGURE 1: Velocity plot

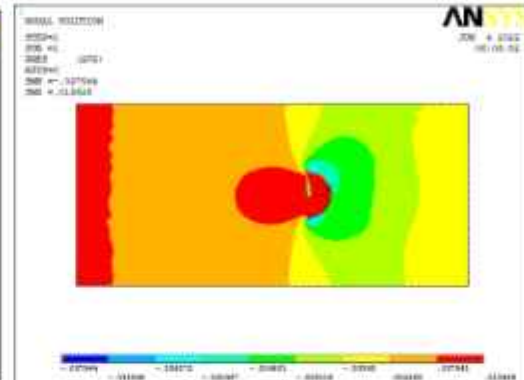

FIGURE 2: Pressure Plot

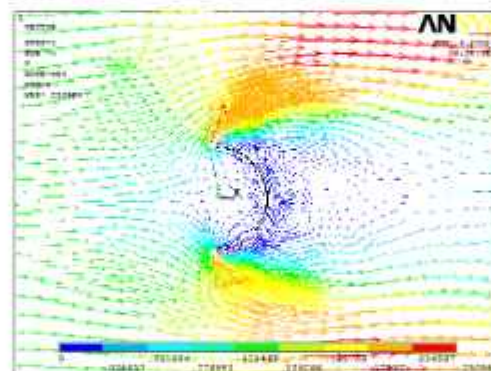

FIGURE 3: Vector plot

Blade Type 2:

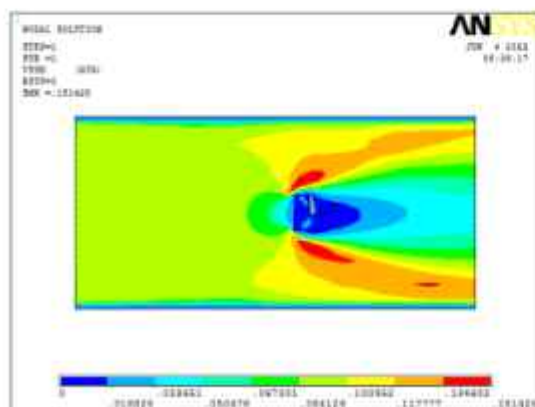

FIGURE 4: Velocity plot

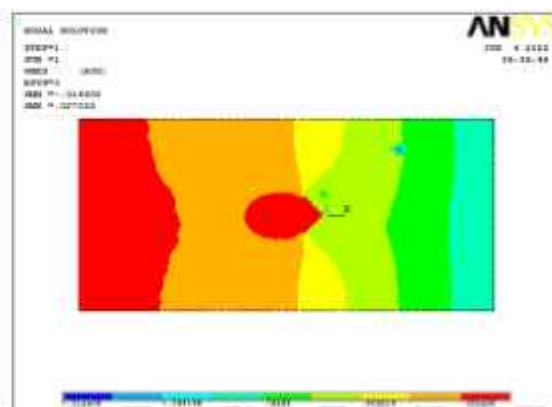

FIGURE 5: Pressure Plot

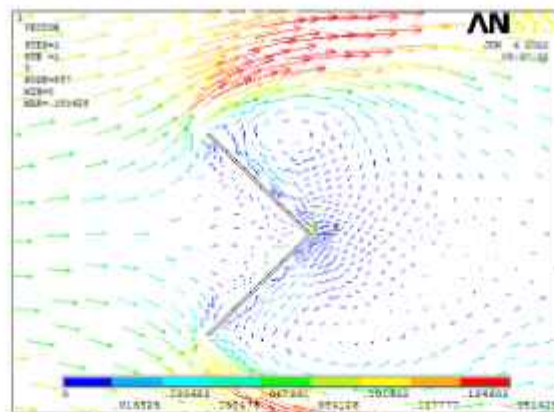

FIGURE 6: Vector plot

Blade Type 3:

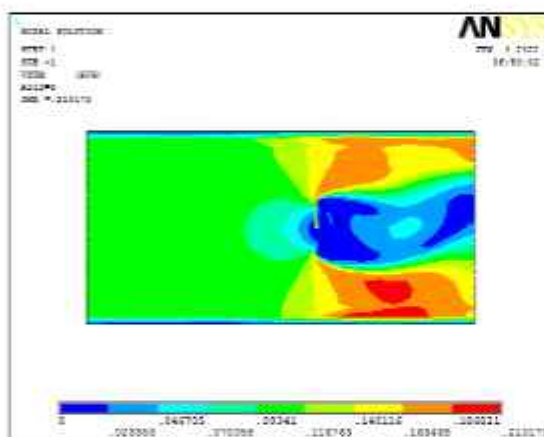

FIGURE 7: Velocity plot

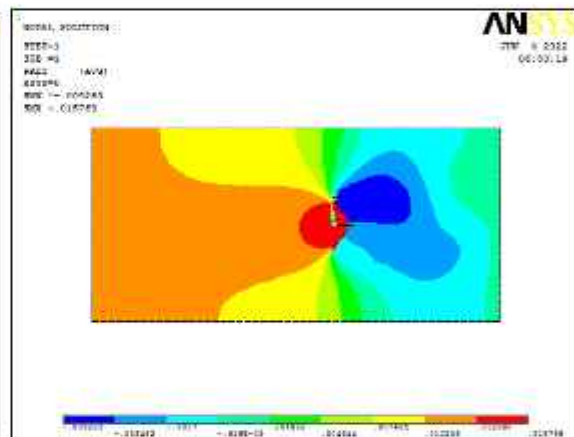

FIGURE 8: Pressure Plot

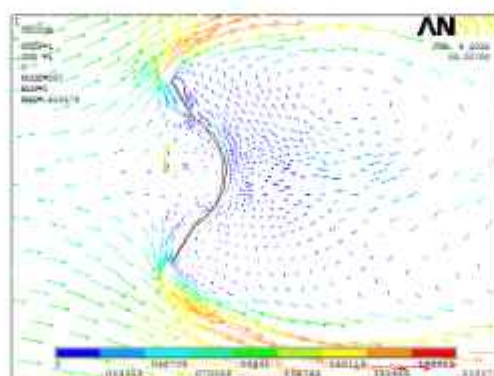

FIGURE 9: Vector plot

Blade Type 4:

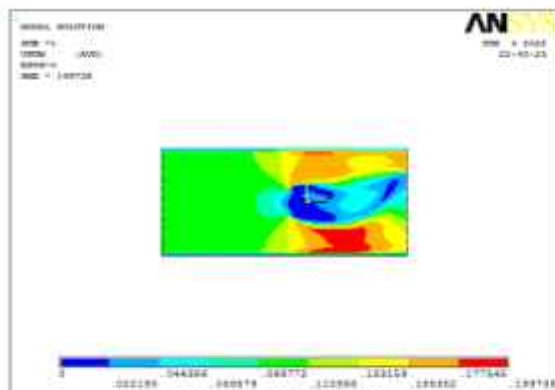

FIGURE 10: Velocity plot

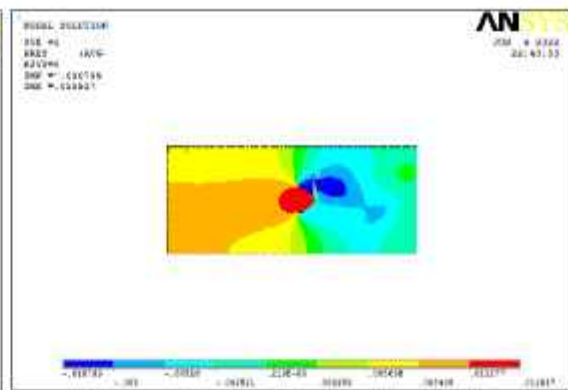

FIGURE 11: Pressure Plot

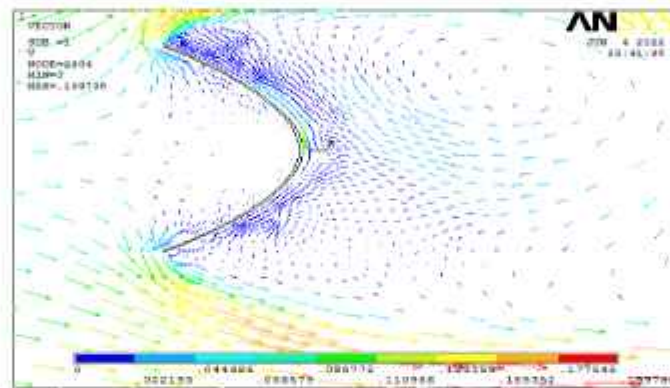

FIGURE 12: Vector plot

Blade Type 5:

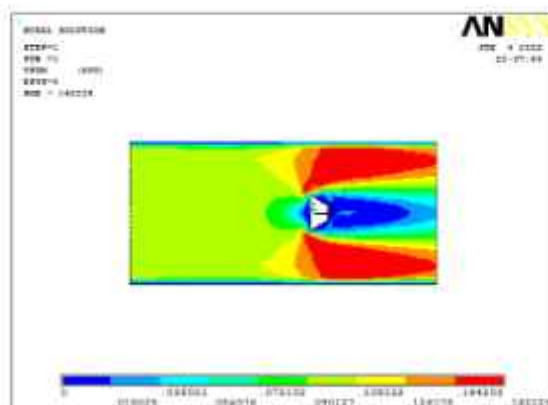

FIGURE 13: Velocity plot

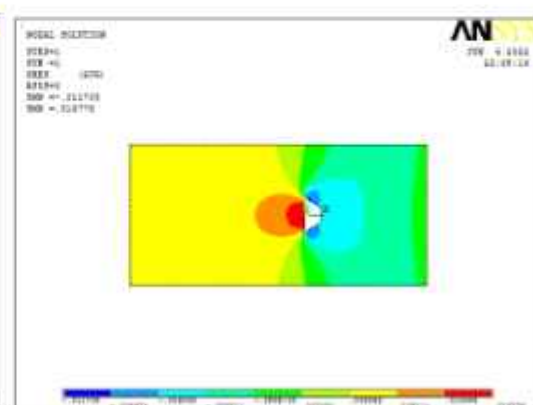

FIGURE 14: Pressure Plot

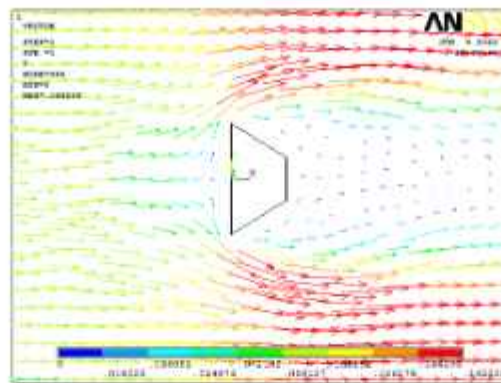

FIGURE 15: Vector plot

### 3. RESULTS AND DISCUSSION

TABLE 1

| SL NO | BLADE TYPE | VELOCITY m/s | PRESSURE N/mm |
|-------|------------|--------------|---------------|
| 1     | Blade 1    | 0.230        | 0.0136        |
| 2     | Blade 2    | 0.151        | 0.027         |
| 3     | Blade 3    | 0.210        | 0.0157        |
| 4     | Blade 4    | 0.199        | 0.0139        |
| 5     | Blade 5    | 0.162        | 0.0137        |

Graph 1

Graph 2

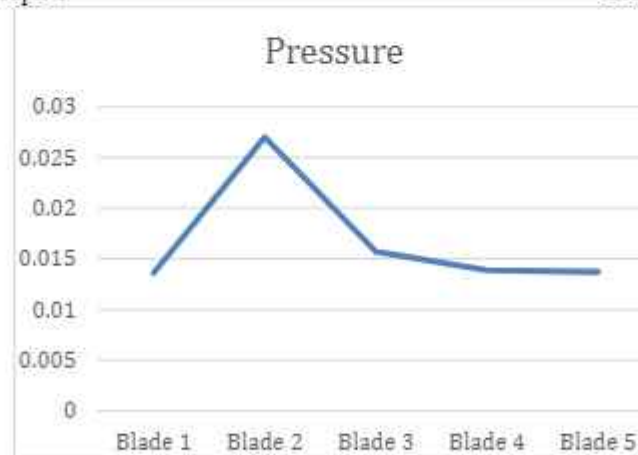



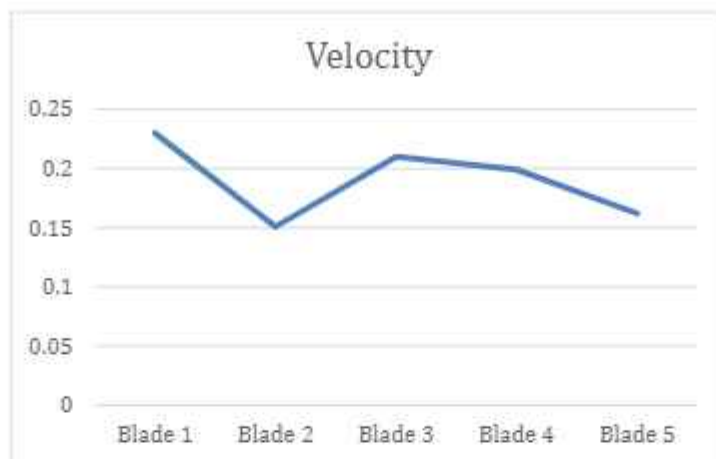

The blade was designed and analyzed using Computational Fluid Dynamics (CFD) by plotting velocity, pressure distribution and streamline flow. We could conclude that the velocity is considerably high in blade type 1 (from table 1). The pressure in blade 2 was found to be more (from table 1), since our project is based on velocity we could conclude that blade type one is most efficient and can capture maximum amount of wind.

## REFERENCES

- [1] MR.BRUCE CHAMPAGNIE, MR. GEATJENS ALTENOR, MR.ANTONIA SIMONIS, Highway Wind Turbines, Florida international university, published on April 12, 2013.
- [2] MOHAMMAD MIYAN, M. K. SHUKLA, Review on Non-Conventional Energy Resources in India, SAMRIDDHI A Journal of Physical Sciences Engineering and Technology, Vol. 10, Issue 2, Published on 16th Nov., 2018.
- [3] W.S. BANNISTER, S. GAIR, Energy for Rural and Island Communities, Published in proceeding of conference, held at Inverness, Scotland Published in March 2019.
- [4] MUHD KHUDRI JOHARI, MUHAMMAD AZIM A JALIL, MOHAMMAD FAIZAL MOHD SHARIFF, MUHD KHUDRI JOHARI MUHAMMAD AZIM A JALIL MOHAMMAD FAIZAL MOHD SHARIFF, Comparison of horizontal axis wind turbine and vertical axis wind turbine, International Journal of Engineering and Technology Published on 13<sup>th</sup> April, 2018.
- [5] R.SATHYANARAYANAN, M.PRASATH, S.MUTHAMIZH, K.T.GOPINATH, The design, development and testing Highway windmill, INDIAN INSTITUTE of ELECTRICAL & ELECTRONICS ENGG., Published in year 2009.
- [6] NABEEL B, FIROZ KHAN T S, KRISHNARAJ V, KANNAN RAJ, ARUN S, SHAIJU MON T K, AKHIL GANESH, Highway Helical Wind Turbine Project, Younus college of engineering and technology, May 17, 2010.
- [7] SAURABH ARUN KULKARNI1 & PROF. M.R. BIRAJDAR Vertical Axis Wind Turbine for Highway Application Imperial Journal of Interdisciplinary Research (IJIR) Vol-2, Issue-10, 2016.

## FABRICATION OF HORIZONTAL CENTRIFUGAL CASTING MACHINE FOR DEVELOPMENT OF AL6061 FUNCTIONALLY GRADED MATERIAL

Kuppala Akhileswr<sup>1</sup>, Devendra G<sup>1</sup>, Lokesh G<sup>1</sup>, Akshay S A<sup>1</sup>, Dr.Nirmala L<sup>2</sup>

<sup>1</sup>Students, <sup>2</sup>Associate Professor

Department of Mechanical Engineering,

K S Institute of Technology, Bangalore-560109, Karnataka, India

### ABSTRACT

*It is essential to manufacture and develop a novel and innovative type of material for better mechanical and tribological traits from the existing one in the field of materials. Latest methods and developments are focused not only to enhance the properties of materials, also to have combinations of properties. One such material is functionally graded material (FGM) and this is also a candidate that will be providing a solution to forthcoming challenging applications in various sectors. In this research, horizontal centrifugal casting machine is fabricated to develop FGMs as this process is widely used, because of its viable capability and minimum technical requirements, compared to other fabrication processes. Using fabricated machine an Al6061 alloy is developed and tested for its hardness. Hardness is determined in radial direction i.e., from outer to inner. Results depict that the sample developed at 1000rpm has high hardness at outer layer than the inner layer because of morphological changes.*

*Keywords: FGM (functionally graded material), centrifugal casting, mechanical, tribological*

### 1. INTRODUCTION

Two or more materials are mixed together to produce FGMs to achieve desired properties [1]. Mechanical and Wear resistance of FGM are found to be better than base materials, combining the contradictory properties of base material into single material. FGMs are different from composite materials (Fig. 1 a) in such a way that, composition of composites is homogeneous, whereas, that of FGM (Fig. 1 b.) is non-homogeneous and gradually varies along its length or volume. The gradient composition leads to change in property along the length of material, due to change in the chemical composition and microstructure.

FGMs are classified by gradient of –chemical composition, microstructure or phases, changing from one end to the other [3,4]. Composites are homogeneous mixture and their properties are mixed properties of both materials, which involve a compromise between the desirable properties. FGM contain the unalloyed form of each material and the need for compromise in properties is disregarded. This helps in utilizing the properties of both materials. For illustration, hardness of a ceramic material can be paired with the ductility of metal, without compromising both hardness and ductility. Based on the type of application the properties of engineering components can be successfully fabricated.

FGM are classified based on three categories: firstly based on nature of gradation, FGM can be continuous or step-wise graded structure [7]. In continuous graded structure, as seen in Fig. 2(a), percentage of composition of a material starts from minimum and increases along the length and ends at 100%. Same situation happens for the second material, but in opposite direction along the length. In contrary, step-wise graded FGM has gradation change in steps as shown in Fig. 2(b). Secondly, based on the gradient, three types of FGMs can be fabricated: (i) chemical composition, (ii) porosity (iii) microstructure. In gradient type of chemical composition, the chemical composition varies along its length and volume.

Though there are various processes available for developing FGMs, an cost effective method for production of the bulk FGMs, liquid metallurgy route with centrifugal force method is preferred for the reason that, it is economically feasible and capable to produce large size products. Centrifugal casting is found to be the simplest and cost effective technique for producing large size engineering components,

such as pipes, shafts, bushings. This project aims to fabricate horizontal centrifugal casting machine and also develop Al6061 alloy using fabricated machine

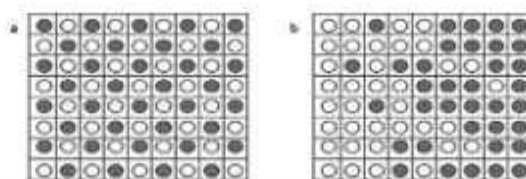

FIGURE 1. a Composite material, (b) functionally graded material [2]

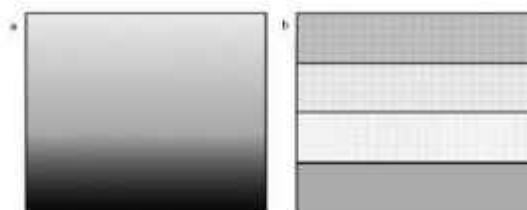

FIGURE 2 (a) Continuous graded FGM, (b) Stepwise FGM gradient materials [8]

## 2. EXPERIMENTAL

### 2.1 MATERIALS

In this project work Aluminium 6061 metal matrix alloy is chosen with density of  $2.7\text{g/cm}^3$  as there is wide scope in structural and engineering applications. horizontal centrifugal casting machine has been used to develop Al 6061 metal matrix alloy. Table 1 show the chemical composition of Al 6061. The die rotational speeds are optimized using empirical analysis considering centrifugal force and gravity force. 1.5 Kg of 6061 alloy was melted in an electrical resistance furnace, at  $780^\circ\text{C}$  the molten metal is poured into the rotating die. A hollow cylinder with length of 100mm, inner radius of 60mm of thickness 15mm was casted as shown in fig 5 (a)

### 2.2 METHODS

Al 6061 alloy is developed using liquid metallurgy route with centrifugal casting process. The following procedure is followed

- Fabrication of centrifugal casting machine

Centrifugal casting equipment includes a cylindrical mould rotated by a motor attached to it as shown in Fig. 4. In this process molten metal is introduced into the die under the gravity force. Gravity force generated due to the rotation of the die, along with the centrifugal force acts on the die. For this reason, die filling is good with effective control of morphology, because of this mechanical properties are enhanced. Based on axis of rotation of die, the casting process can be classified as vertical centrifugal casting process and horizontal centrifugal casting process. In vertical centrifugal casting, the axis of rotation of the die is vertical and is preferred when only small parts in small numbers such as short bushings, sprockets, etc. are to be produced. In horizontal centrifugal casting, the axis of rotation is horizontal and is preferred for producing large components in mass production such as pipes, rolls for steel mills, etc.

A. The basic steps in centrifugal casting process are:

The die is mounted on the prime mover shaft and rotated along a vertical (rpm is reasonable), or horizontal axis.

1. The die is coated with refractory liners for easy removal of solidified component.
2. While rotating molten metal is poured in.
3. The metal that is poured in will then distribute itself over the rotating wall.
4. During cooling lower density impurities will tend to rise towards the centre of rotation.
5. After the part has solidified, it is removed and finished.

The produced workpieces in shape of a hollow cylinders of 60mm and 100mm length with thickness of 15mm. the volume of poured metal is 1500 grams for each casting as shown in fig 5 a.



FIGURE 4. a)Horizontal centrifugal casting machine

TABLE 1. Process parameters used in centrifugal casting

| Process parameters     | Range                    |
|------------------------|--------------------------|
| Pouring Temperature    | 780 <sup>o</sup> c       |
| Mould rotational speed | 600rpm,800rpm & 1000 rpm |

- Mold Speed of Rotation:**

From literature, to select optimum speed of the mold in horizontal centrifugal casting machine and for the process to work successfully. G factor should be calculated. If the G-factor (GF) is too low in centrifugal casting, the liquid metal will not remain forced against the mold wall during the upper half of the circular path but will "rain" inside the cavity. Slipping occurs between the molten metal and the mold wall, which means that the rotational speed of the metal is less than that of the mold. As per literature values of [GF = 60 to 80] are found to be appropriate for horizontal centrifugal casting.

G-factor GF is the ratio of centrifugal force divided by weight.

Centrifugal force is

$$F = \frac{MV^2}{R}$$

The force of gravity is its weight  $W=mg$ , where  $m$  is the mass in kg, and  $g$  = acceleration of gravity, 9.8 m/s<sup>2</sup>.

$$GF=CF/\text{Force of gravity}$$

The G-factor at 1000 rpm

Linear Velocity  $V$  of the die can be expressed as:

$$V = \frac{2\pi RN}{60} = (2 * \pi * 0.06 * 1000) / 60 = 6.28 \text{ m/s}$$

Where:  $N$  = rotational speed, rev/min

Gravity Factor

$$GF = \frac{mv^2}{Mg} = \frac{v^2}{Rg} = 6.28^2 / (0.06 * 9.8) = 67.003$$

G factor= 67.003,

The Molten metal will remain forced against the mold walls during the circular path with the same G factor. For horizontal centrifugal casting the G factor should be between 60 and 80 for better mechanical properties.so the optimum die speed for better mechanical properties is die speed of 1000 rpm. The process parameters are shown in Table 1

TABLE 2: Chemical Composition of Aluminium 6061 alloy

| Elements | Mn   | Cr   | Fe   | Cu   | Si   | Mg   | Zn  | Ti   | Al      |
|----------|------|------|------|------|------|------|-----|------|---------|
| (wt.%)   | 0.01 | 0.05 | 0.17 | 0.33 | 0.71 | 1.12 | 0.1 | 0.01 | Balance |



FIGURE 5.a) Casted specimens b) Samples machined from cast

### 2.3 Characterization methods

The following are the experiments carried out on the alloy developed –

- **Micro structural investigation**

Samples were prepared from casted parts (outer, centre and inner) and were ground using emery papers of different grades and diluted alumina solution to achieve scratch free surface. diamond polishing was carried out to attain mirror polished surface. Microstructure analysis was performed to depict the grain size in various layers in order to analyse the effect of pouring temperature, die speed. As shown in fig 4(c)

- **Mechanical properties**

Samples were prepared from the cast (as shown in fig 5b.) and Hardness test was conducted for inner, centre and outer region of casted component using Brinell Hardness Testing machine. The samples were fixed in holder, and ball indenter was subjected to load on the surface. Multiple readings were taken at different positions and average is used for different samples as shown in fig6 The results are tabulated in table 2.

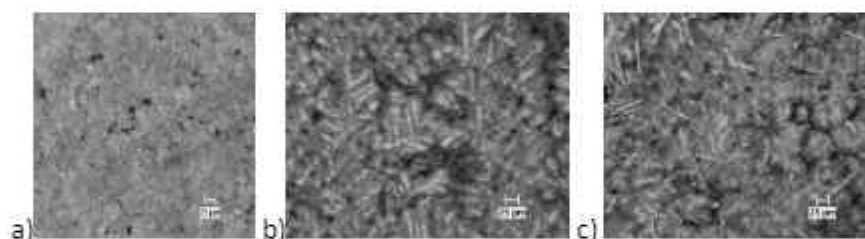

FIGURE 6. Microstructural features of aluminum 6061 alloy (a) (100X) outer(b) middle (100x)(c) (100X)Inner

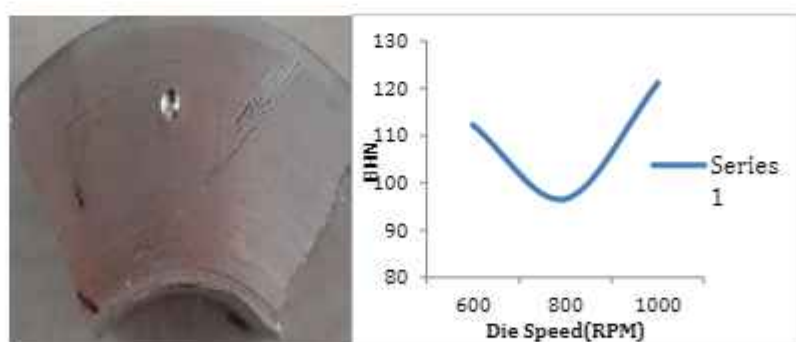

FIGURE 7. Hardness specimen

FIGURE 8. Graph of Die speed vs BH

TABLE 2: Hardness test results

| Sl.No | RPM  | Trail  | Load kg | Dia of ball indenter mm | Dia of Indentation mm | Area of indentation mm <sup>2</sup> | BHN    | Average |
|-------|------|--------|---------|-------------------------|-----------------------|-------------------------------------|--------|---------|
| 1     | 600  | Inner  | 187.5   | 2.5mm                   | 1.5                   | 1.9634                              | 95.49  | 112.26  |
| 2     |      | Center |         |                         | 1.4                   | 1.68                                | 111.60 |         |
| 3     |      | Outer  |         |                         | 1.2                   | 1.43                                | 131.11 |         |
| 4     | 800  | Inner  | 187.5   | 2.5mm                   | 1.6                   | 2.27                                | 82.59  | 96.56   |
| 5     |      | Center |         |                         | 1.5                   | 1.9634                              | 95.49  |         |
| 6     |      | Outer  |         |                         | 1.4                   | 1.68                                | 111.60 |         |
| 7     | 1000 | Inner  | 187.5   | 2.5mm                   | 1.5                   | 1.9634                              | 95.49  | 121.11  |
| 8     |      | Center |         |                         | 1.4                   | 1.68                                | 111.60 |         |
| 9     |      | outer  |         |                         | 1.3                   | 1.20                                | 156.26 |         |

### 3. RESULTS AND DISCUSSION

From literature survey the optical micrographs of centrifugally casted component should have finer grains at outer surface due to rapid solidification and coarser grains on the inner surface due to slower solidification, hence gradient and combination of properties is achieved. if reinforcements are added they spread to the outer periphery in large number and lesser number towards inner surface. The microstructure of

So using centrifugal casting it is economical to produce FGMs than conventional methods. Fig 7 shows the variation of hardness with die speed. The variation of hardness within the casting ie. from inner to outer surface is marginal. The hardness on the inner and middle surface of all the samples tested is 95.49 and 111.60 respectively. The hardness on the outer surface for die speed of 600, 800, and 1000 rpm are 156.26, 111.60 and 131.11 respectively.

The hardness on the outer surface of all the samples is greater than the hardness at inner and centre surfaces. At the outer surface the grains are finer than the grains of centre and inner surfaces, so hardness at the outer surface is higher.

### 4. CONCLUSION

Al 6061 alloy is successfully casted using fabricated horizontal centrifugal casting machine. The experimentation revealed that process of centrifugal casting is very much economical and ease to fabricate functionally graded materials.

Centrifugal casting process is very much economical and ease to fabricate FGMs. The factors to consider are pouring temperature, cooling rate, reinforcement size and speed of rotating mould. The controlling of process variables will help to enhance the properties of the material which is casted. The FGMs produced using this process are finding usefulness in almost all sectors.

From literature the hardness of Al 6061 is 60BHN when produced using conventional methods. But using centrifugal casting the average hardness value of Al6061 is 106.89. so using centrifugal casting process the mechanical properties of Al 6061 can be enhanced

### REFERENCES

- [1] Zhang Zhongtao, Li Tingju, Hongyun Yue, Zhang Jian, Li Jie, Preparation of Al/Si functionally graded materials using ultrasonic separation method, China Found. 53 (3) (2008) 194–198.
- [2] Dragan Cukanovic, Aleksandar Radakovic, Dragan Milosavljevic, Gordana Bogdanovic, L.J. Veljovic, Thermal buckling analysis of metal-ceramic functionally graded plate according to high order shear deformation theory, J. Balkan Tribol. Assoc. 23 (3) (2017) 413–430.
- [3] C. Jiang Song, Z. Ming Xu, L. Jian-Guo, Fabrication of in Situ Al/Mg<sub>2</sub>Si functionally graded materials by electromagnetic separation method, Compos. A Appl. Sci. Manuf. 38 (2) (2007) 427–433.
- [4] S.S. Alieldin, A.E. Alshorbagy, M.A. Shaat, A first-order shear deformation finite element model for

- elastostatic analysis of laminated composite plates and the equivalent functionally graded plates, *Ain Shams Eng. J.* 2 (1) (2011) 53–62.
- [5] A.G. Arsha, E. Jayakumar, T.P.D. Rajan, V. Antony, B.C. Pai, Design and fabrication of functionally graded in-situ aluminium composites for automotive pistons, *Mater. Des.* 88 (2015) 1201–1209.
- [6] Y. Miyamoto, W.A. Kaysser, B.H. Rabin, A. Kawasaki, R.G. Ford, *Functionally Graded Materials: Design, Processing and Applications*, Kluwer Academic Publishers, Boston, 1999.
- [7] R.M. Mahamood, E. Titilayo Akinlabi, *Functionally graded materials*, *Top. Min. Metall. Mater. Eng.* <https://doi.org/10.1007/978-3-319-53756-6>.
- [8] A. Edwin, V. Anand, K. Prasanna, Sustainable development through functionally graded materials: an overview, *Rasayan J. Chem.* 10 (1) (2017) 149–152.
- [9] R.M. Mahamood, E.T. Akinlabi, Laser-metal deposition of functionally graded Ti6Al4V/TiC, *Mater. Des.* 84 (5) (2015) 402–410.
- [10] R.M. Mahamood, E.T. Akinlabi, M. Shukla, S. Pityana, Functionally graded material: an overview, *Proc. World Cong. Eng.* 3 (2012) 1593–1597.
- [11] R.M. Mahamood, E.T. Akinlabi, Modelling of process parameters influence on degree of porosity in laser-metal deposition process, in: G.C. Yang (Ed.), *Transactions on Engineering Technologies*, Springer, 2015, pp. 31–42.
- [12] X. Miao, D. Sun, Graded/gradient porous biomaterials, *Materials* 3 (1) (2010) 26–47, <https://doi.org/10.3390/ma3010026>.
- [13] M.J. Schneider, The Timken Company, and Madhu S. Chatterjee: Bodycote, Introduction to surface hardening of steels, in: J. Dossett, G.E. Totten (Eds.), *ASM Handbook, Steel Heat Treating Fundamentals and Processes*, 4A, 2013.
- [14] L. Lu, M. Chekroun, O. Abraham, V. Maupin, G. Villain, Mechanical properties estimation of functionally graded materials using surface waves recorded with a laser interferometer, *NDT E Int.* 44 (2) (2011) 169–177.
- [15] S. El-Hadad, H. Sato, E. Miura-Fujiwara, W. Yoshimi, Fabrication of Al-Al<sub>3</sub>Ti/ Ti<sub>3</sub>Al functionally graded materials under a centrifugal force, *Materials* 3 (9) (2010) 4639–4656.
- [16] S.N.S. Jamaludin, F. Mustapha, D.M. Nuruzzaman, S.N. Basri, A review on the fabrication techniques of functionally graded ceramic-metallic materials in advanced composites, *Sci. Res. Essays* 8 (21) (2013) 828–840.
- [17] Gururaj Udupa, S. Shrikantha Rao, K.V. Gangadharan, Functionally graded composite materials: an overview, *Int. Conf. Adv. Manuf. Mater. Eng. Proc. Mater. Sci.* 5 (2014) 1291–1299.
- [18] A. Roey, S. Vasseur, in: *ASM Hand book – Casting*, ASM International, Ohio, 1988, p. 296.
- [19] Y. Watanabe, I.S. Kim, Y. Fukui, Microstructures of functionally graded materials fabricated by centrifugal solid-particle and in-situ methods, *Met. Mater. Int.* 11 (5) (2005) 391–399.
- [20] Minoo Naebe, Kamyar Shirvanimoghaddam, Functionally graded materials: a review of fabrication and properties, *Appl. Mater. Today* 5 (2016) 223–245.



ಕನ್ನಡ ಸಂಘ ಸಮುದಾಯ ಭವನ  
K.S. INSTITUTE OF TECHNOLOGY

DEPARTMENT OF MECHANICAL ENGG. & LIBRARY

DEPARTMENT OF MECHANICAL ENGG. & LIBRARY  
K.S. INSTITUTE OF TECHNOLOGY

# K.S. INSTITUTE OF TECHNOLOGY

#14, RAGHUVANAHALLI, KANAKAPURA ROAD BENGALURU - 560109